

AMS220 – Voltage controlled current source with active common mode rejection



Features

- Patented common mode rejection technology (U.S. #9,285,809, March 2016)
- Output current to ± 50 mA
- Voltage-to-current conversion ranges from $1 \mu\text{A/V}$ to 10 mA/V
- ± 5 V control voltage input range
- Low-noise, all analog design
- Optimized for use with lock-in amplifiers

... for lock-in amplifier users performing very-low resistance measurements in the most demanding conditions

Targeted application

- “Open architecture” AC resistance bridge when used with lock-in amplifier *)
 - Very-low-resistance measurements down to mK temperatures, e.g.
 - Superconductivity research
 - Hall resistance measurements
 - Simultaneous resistance and Hall resistance measurements (with two lock-in amplifiers)
 - Higher harmonic detection (e.g. 2ω , 3ω) in resistance measurements
 - Thermometry/calorimetry
 - Mutual inductance measurements
- AC and DC electrical measurements with DAQ devices *)
- Replaces floating current sources in resistance measurements

*) The use of the preamplifier AMS560 (Gain=1000) is recommended for measurements in micro- and nanovolt signal levels

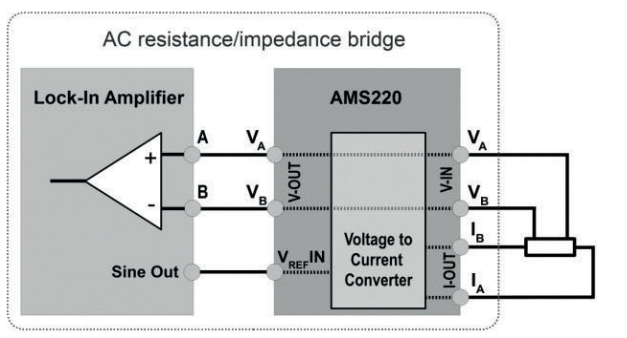

The AMS220 voltage controlled current source with active common mode rejection

...brings a unique possibility for researchers to perform low-level electrical measurements requiring precise current excitation at the negligible level of common mode voltage. The AMS220 is preferentially designed for low-noise resistance measurements using a lock-in amplifier, where in combination with the high-sensitivity lock-in amplifier measurements of very low resistance (less than $1 \text{ m}\Omega$) become a routine even in the most demanding conditions (e.g., temperatures below 500 mK). In this sense, the AMS220 opens new experimental possibilities especially for researchers working in the field of superconductivity and electrical transport phenomena.

Alternatively, the AMS220 can also be used in combination with DAQ devices in many types of DC or AC electrical measurements, where well defined current excitation of D.U.T. is required. Applications include e.g., resistance measurements, thermometry, or I-V curves measurements.

Build your own ‘open architecture’ AC resistance bridge

The functionality of an AC resistance bridge is obtained simply by interconnecting reference voltage output (Sine Out) and voltage sensing inputs of lock-in amplifier with the corresponding input and outputs of the AMS220, while the tested resistance is connected to the AMS220. The excitation current provided by the AMS220 is then proportional to the reference voltage provided by the lock-in amplifier and switch-programmable voltage-to-current conversion factor of the AMS220. Connection of the AMS220 in the configuration replacing the AC resistance (impedance) bridge is schematically shown in the figure on the left.

AMS220 – Voltage controlled current source with active common mode rejection

Eliminate common mode errors in your low-level resistance measurements

Benefits of the patented common mode voltage rejection technology of the AMS220 can be illustrated using the following example.

If you are attempting to measure a test resistor of $0.1 \text{ m}\Omega$ resistance using the test current of $10 \text{ mA}_{\text{RMS}}$, the voltage across the test resistor is $0.1 \text{ m}\Omega \times 10 \text{ mA}_{\text{RMS}} = 1 \text{ }\mu\text{V}_{\text{RMS}}$.

However, if one of the current leads in your experimental setup is connected to a signal ground of an experimental setup and resistance of the corresponding current path is $20 \text{ }\Omega$, then the signals at the voltage sense inputs of a (grounded) voltage-sensing instrument will contain an AC component ($20 \text{ }\Omega \times 10 \text{ mA}_{\text{RMS}} = 200 \text{ mV}_{\text{RMS}}$), which is very much greater than the voltage difference of these signals ($1 \text{ }\mu\text{V}_{\text{RMS}}$); the corresponding common mode voltage (defined as the average value of voltage potential at sense inputs with respect to the signal ground) is $200.0005 \text{ mV}_{\text{RMS}}$.

Considering an industry standard lock-in amplifier with Common Mode Rejection (CMR) of $\approx 100 \text{ dB}$ (i.e. with suppression of common mode voltage $\approx 10^5$ times), an estimate for common mode error is $200 \text{ mV}_{\text{RMS}}/10^5 = 2 \text{ }\mu\text{V}_{\text{RMS}}$. Because the result provided by the lock-in amplifier is a sum of the voltage difference of the signals applied to its voltage-sensing inputs ($1 \text{ }\mu\text{V}_{\text{RMS}}$) and common mode error ($2 \text{ }\mu\text{V}_{\text{RMS}}$), the result provided by the lock-in amplifier will be **$3 \text{ }\mu\text{V}_{\text{RMS}}$ instead of $1 \text{ }\mu\text{V}_{\text{RMS}}$** ! Of course, this is an artificial result, which in this example is even 3-times greater than the real value!

If the AMS220 is used to excite the test resistance with enabled active common mode rejection circuit, this circuit suppresses the common mode voltage typically to the level of a few microVolts, or less. Based on this fact, it can be estimated that for instruments having $\text{CMR} = 100 \text{ dB}$ (or greater) corresponding common mode error will not exceed tens of picoVolts. Taking into account sensitivity limitations of industry standard lock-in amplifiers, it can be concluded that resistance measurements utilizing AMS220 are not affected by common mode errors. AMS220 is the only current source on the market possessing (patented) active common mode rejection capability.

Related products - Preamplifiers AMS540 and AMS560

The preamplifiers **AMS540** (Gain: 100) and **AMS560** (Gain: 1000) are designed for use with the current source AMS220 and are powered by the AMS220.

AMS540 is dedicated to measurements requiring high input impedance of a voltage-sensing instrument (with a bias current of the inputs not exceeding tens of picoVolts). The AMS540 can be also favourably used to perform sensitive measurements with DAQ devices not having millivolt ranges. The frequency range is from DC to 20 kHz.

AMS560 Preamplifier (Gain=1000) is to perform very-low resistance measurements (with excitation currents greater than $\approx 50 \text{ }\mu\text{A}$). The AMS560 can be also favourably used to perform sensitive measurements with DAQ devices not having millivolt ranges. Frequency range of the AMS560 is from DC to 200 Hz, thus it covers the whole frequency range of the AMS220 operating in the mode with enabled active common mode rejection circuit.

Basic specifications	
Ranges of voltage-to-current conversion	0.001, 0.01, 0.1, 1, 10 [mA /V]
Control voltage input range	$3.6 \text{ V}_{\text{RMS}} / \pm 5 \text{ VDC}$
Maximum $\text{AC}_{\text{RMS}}/\text{DC}$ output current	$36 \text{ mA}_{\text{RMS}} / \pm 50 \text{ mA}_{\text{DC}}$
Targeted frequency range	DC - 200 Hz @ 'ACTIVE CMR' operation mode ENABLED
	DC - 20 kHz (2 kHz for $1 \text{ }\mu\text{A}/\text{V}$ range) @ 'ACTIVE CMR' operation mode DISABLED
Power	12 V (AC) / 0.6 A (powered by 12 V AC adapter)