

CORDIN

SCIENTIFIC IMAGING

| TEMPORAL PIXEL MULTIPLEXED (TPM) FRAMING CAMERA

Model TPM-1000

- **Very high framing rate:** up to 10 million fps
- **Flexible:** variable tradeoff between number of frames and resolution (up to 1K x 1K)
- **Solid-state design:** no moving parts
- **Software control:** easy control of exposure and timing parameters through user-friendly PC software
- **Laser and pulsed flash illumination synchronization**
- **Uses standard C-mount objective lenses** (not included)



The **Cordin Model TPM-1000** high-speed CMOS camera offers a ground-breaking combination of 10 Mfps high-speed framing camera performance with a dramatic new pricepoint and compact package size. The Cordin TPM-1000 captures images at frame rates of up to 10 million frames per second and up to 1 mega-pixel resolution. The system uses a new TPM architecture jointly developed by Cordin and Oxford University with a unique CMOS sensor chip capable of capturing sub-array images in a burst mode.

With its flexible TPM architecture, the TPM-1000 allows the user to trade off the number of frames in a burst versus resolution, given the available on-chip pixel memory.

The Model TPM-1000 camera can be triggered by the event being photographed, and can accept triggers in advance or for some time after the event of interest. It can also provide the trigger to initiate the event.

The system comes complete with Cordin's control software application, and is controlled via Ethernet interface by the customer's choice of standard Windows-based PC or laptop. Data may be saved in a wide variety of 8 bit file formats. Full 10 bit images are saved in 16 bit TIFF file format.

OPTIONS

Illumination Sources (Models 605, 606, 607)

Objective Lenses and Microscope Objectives

Nikon F-mount Adapter

Time Delay Generators (Models 454, 458)

CORDIN

SCIENTIFIC IMAGING

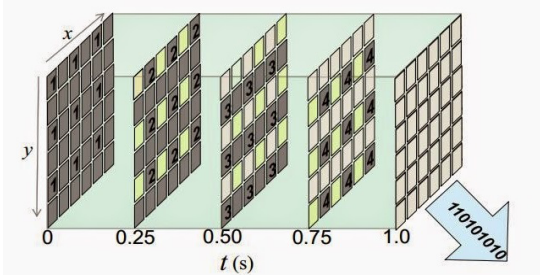

Temporal Pixel Multiplexing (TPM)

TPM operation at 512x512 resolution

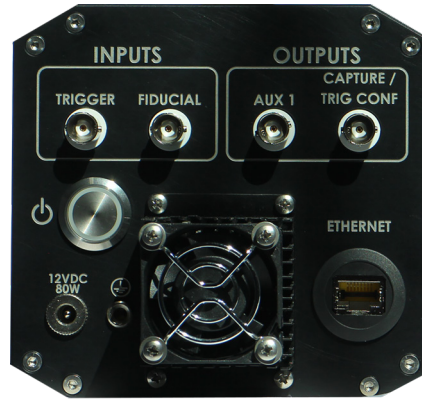

TPM-1000 Rear I/O Panel

SPECIFICATIONS

Number of Frames	Configurable	Max Full Well Capacity	52.5 Ke-
Maximum Framing Rate	10 million FPS	Noise	35 e-
Front Optics	Single objective lens system (no parallax)	Fill Factor	31%
Objective Lens	C-mount or Nikon F-mount (not included)	Device Type	Variable resolution progressive scan CMOS Sensor Monochrome
Sensor Size	14 mm x 14 mm	Interface	Gigabit Ethernet for camera control and image transfer
Resolution	1K x 1K pixels	Dimensions	127 mm x 157 mm x 179 mm
Pixel size	10 μ m pitch	Weight	1.8 Kg (3.9 lbs.) - w/o lens
Dynamic Range	10 Bit		

FRAME CAPACITY

	Resolution	1Kx1K	512x512	340x340	256x256	...	32x32
Frames per burst							
Max frames @ all frame rates:		1	4	9	16	...	1024

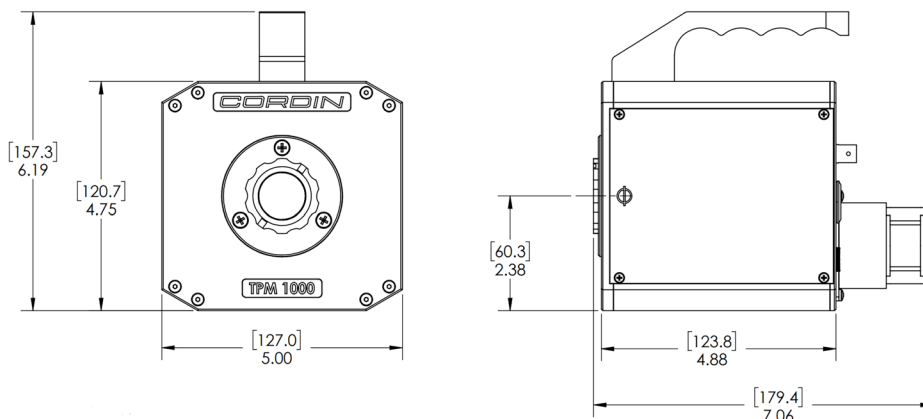

PRELIMINARY SPECIFICATION: SUBJECT TO CHANGE