

# FAAST-Phase™

## Revolutionary X-ray source designed for Talbot interferometry

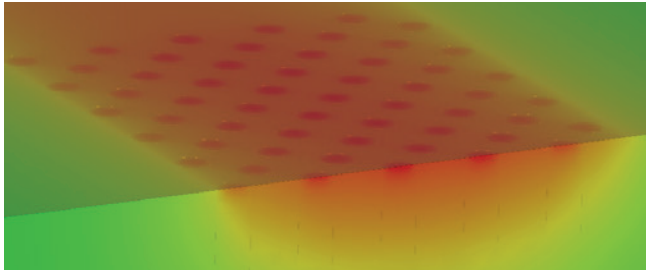

### World's brightest X-ray source... Designed for unlocking the potential of phase contrast X-ray

Finite Element Analysis results of Sigray's patent-pending FAAST-Phase x-ray source target, demonstrating the thermal advantages of its microstructured design and using a diamond substrate. The specific model shown below employs cylindrical copper microstructures.

### Accelerate your phase contrast research

### Highest brightness x-ray beam for developing grating-based systems

Grating-based Talbot Interferometry is one of the most exciting new methods that has emerged in x-ray physics over recent years. Synchrotron experiments have demonstrated significant promise for medical imaging and polymeric material analysis. Laboratory-based approaches have also developed, typically by placing a high aspect ratio source grating (GO) in front of a large extended x-ray source to effectively produce an array of small x-ray sources with the spatial coherence required for the technique to succeed.

However, the use of GO also introduces numerous problems:

- Inefficient use of x-rays that limits throughput
- Constraints on field of view
- Contrast limitations from partial transmission of x-rays through the grating
- Manufacturing challenges make it near-impossible to achieve usable gratings with openings of  $1\ \mu\text{m}$

### Benefits over using the combination of a rotating anode source w/GO grating:

- High source brightness for rapid phase contrast data acquisition
- Throughput gains of  $\sim 4x$  over the high powered rotating anode & source grating (GO) approach
- Effective source size is  $1\ \mu\text{m}$ , which produces large Talbot fringes to reduce requirements on downstream detector and detector grating components
- Optimized contrast preservation due to an improved patterned microbeam with darker nodes and brighter anti-nodes
- Reduced complexity in system design by removing GO

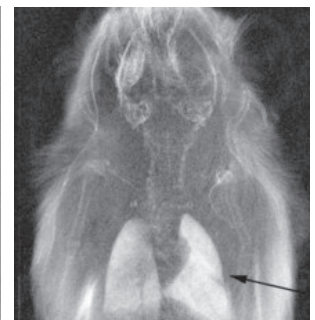
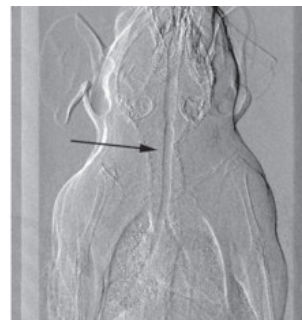
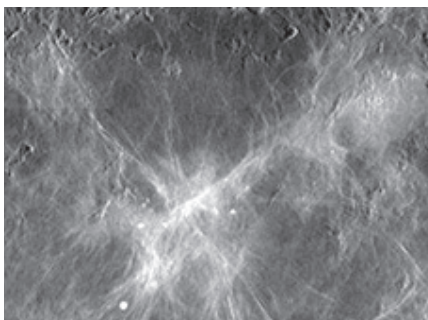
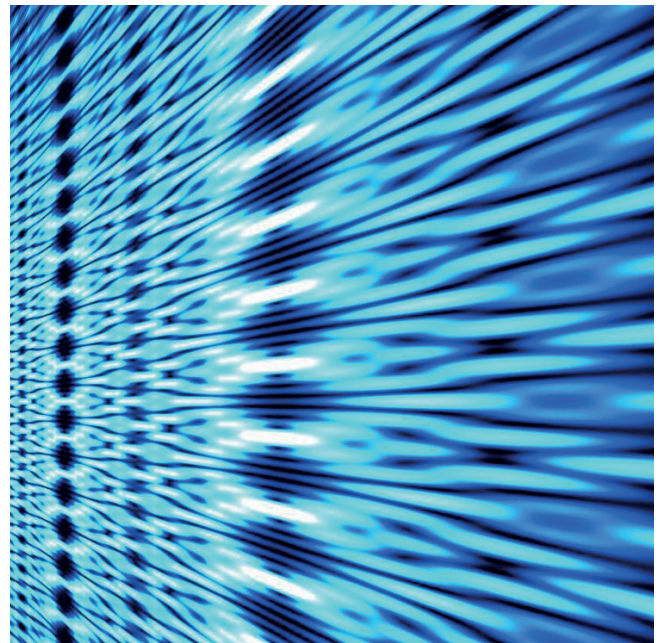

Grating-based images by Pfeiffer et al., ETH Zurich of a tumorous breast cancer tissue sample (left) and by Bech et al., Lund University of a rat (right three)

# FAAST-Phase™

## Revolutionary X-ray source designed for Talbot interferometry

The Sigray FAAST-Phase™ (Fine Array Anode Source Technology) features an innovative x-ray target comprised of an array of fine microstructured metal x-ray emitters embedded in a diamond substrate. The target is designed to combine the advantages of:

- Rapid thermal dissipation, provided by high degree of contact between the microstructures and diamond (thermal conductivity: 22 W/cm<sup>2</sup>) to enable highly localized thermal gradients so that the target remains cool under high power loading
- Low atomic number of diamond, which results in a near-ideal electron energy deposition in the metal microstructures so that x-rays are efficiently produced by the metal microstructures for high contrast Talbot fringes
- 1 micron microstructure size for high spatial coherence, which relaxes requirements for downstream gratings and detector

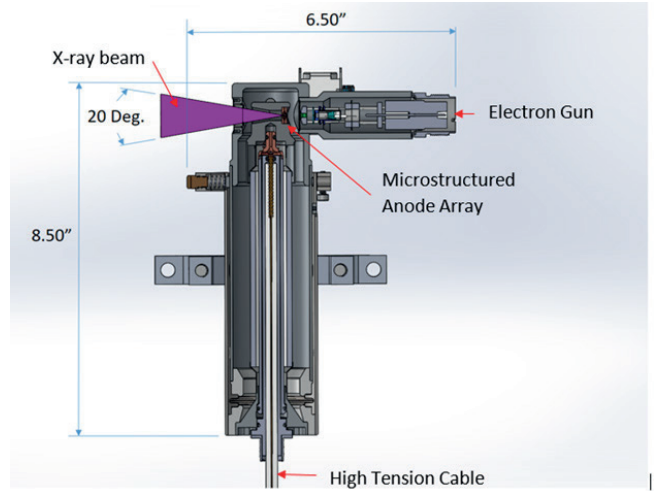

Parameter	Specification
Anode design	Periodic linear array of x-ray micro-emitters (2D array option also available upon request), circular pattern
Microstructure material	Copper (Cu) standard. Other materials (Ti, Cu, Rh, W, Pt, Zr, etc.) available on request.
Microstructure dimensions	Width (d0): 1 μm, Pitch (p0): 3 μm
Spot size diameter (D)	20 and 50 μm diameter round
Maximum power	75 W (50 μm)
Power density	75 kW/mm <sup>2</sup> Note that a fair comparison to rotating anode would include account for self-absorption of take-off angle and aspect ratio of the grating (around a factor of 9) - the effective power density of a 1 kW 75 μm rotating anode is around 19 kW/mm <sup>2</sup>
Voltage	20 - 50 kV
Current	4 mA
Dimensions (W x L x H)	6.5" x 6.5" x 8.5"   16.5 cm x 16.5 cm x 21.6 cm (source) 13" x 11" x 13"   33 cm x 28 cm x 33 cm (cooling unit)
AC Power requirements	110 V or 220 V (selectable)

