

Hyperspectral VisNIR high-speed camera FX10+



The Specim FX10+ is a high-speed line-scan hyperspectral camera optimized for applications requiring fast imaging. Its high resolution ensures accurate and detailed imaging at a rapid pace. Specim FX10+ operates in the visible and near-infrared (VNIR) region from 400 to 1000 nm.

Specim FX10+ is ideal for applications where rapid data collection is essential, such as:

- Food sorting
- Food quality
- Color & density in printing
- Display & light source inspection
- Vegetation & agriculture
- Phenotyping

FEATURES

- Spectral range of 400-1000 nm
- High spatial resolution of 1024 pixels
- High image speed of 705 FPS (2-spectral bin)
- Free wavelength selection from 200 (2-spectral bin) bands within the camera coverage
- Built-in image correction
- Unified spectral calibration between units
- GigE standard interface
- Easy mounting to industrial environment
- Certificates: CE, RoHS

SPECTRAL RESPONSE

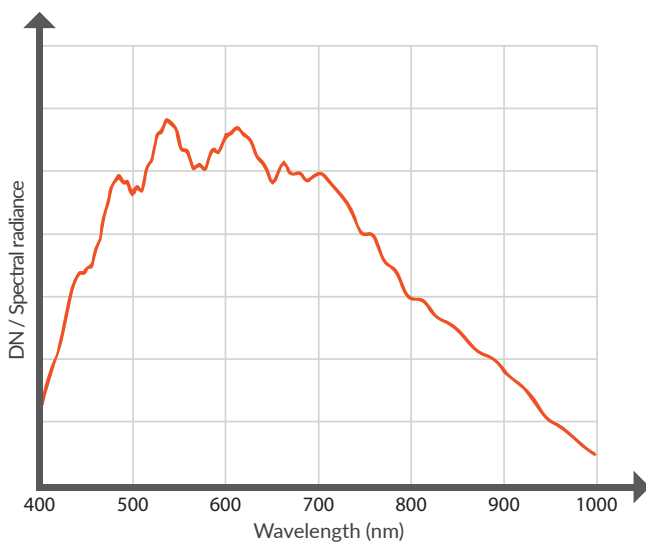

DIMENSIONS

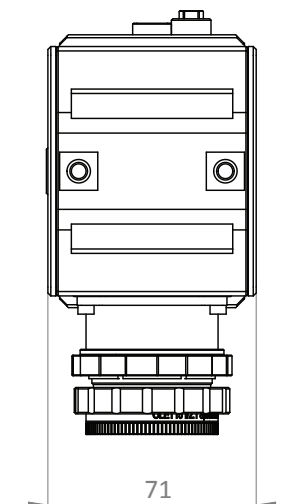
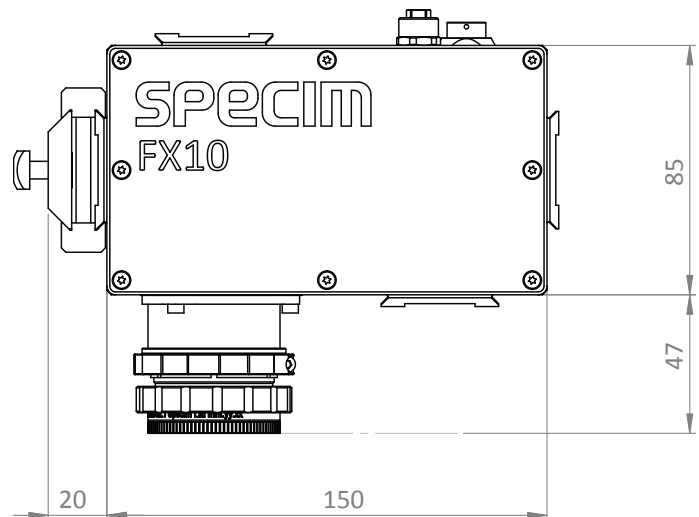

Learn more:



Hyperspectral VisNIR high-speed camera FX10+

Spectral Range	400-1000 nm	
Spectral resolution (FWHM)	15 nm	Typical mean
Spectral sampling/pixel	6.3 nm	With default binning
Spectral bands	100	With default binning
Numerical aperture	1.7	With default lens
Optics magnification	0.80	
Effective pixel size	19.9x9.97 µm	At fore lens image plane
Effective slit width	42 µm	At fore lens image plane
Effective slit length	10.2 mm	At fore lens image plane
SNR @ max. signal	420 : 1	
Spatial samples	1024	
Bit depth	12	
Maximum frame rate	705 FPS full range	With 2-spectral binning: Bands Max FPS 1 9900 5 6500 20 2800 35 1813 70 985
Binning	2,4,8 spectral and spatial	Default: 2 spectral x 1 spatial
ROI	Freely selectable multiple bands of interest	Minimum height of ROI is two 1-binned rows. Maximum frame rate is determined by the total number of rows included in the mMROI's
Pixel operability	99.993%	
Image corrections	Non uniformity correction Bad pixel replacement Automatic Image Enhancement (AIE)	One point NUC AIE: Unified spectral calibration + corrected smile and keystone aberrations
Sensor material	CMOS	
Sensor cooling	Passive	
Full well capacity	90 ke-	
Read-out modes	IWR / ITR	
Optics temperature	Passive	
Lens mount	Custom mount	
Fore lens FOV options	12 deg 38 deg (default) 47 deg 51 deg 83 deg	Only the default lens is specifically designed for FX10. With other lens options, optical parameters may vary.
Camera digital data output/control interface	GigE Vision	
Camera control protocols	GenICam, ASCII	
Power input	12 V DC (+-10%)	
Power consumption	Max 4 W	
Connectors	Industrial Ethernet	
IP	IP52	
Dimensions (L x W x H)	150 x 85 x 71 mm	Mounting surface option on three sides. Mounting kit adds 24 mm distance on mounting side.
Weight	1.3 kg	
Storage temperature	-20 ... +50°C (non-condensing)	
Operating temperature	+5 ... +40°C (non-condensing)	
Relative humidity	5% – 95% (non-condensing)	