

High-speed spectral camera FX50



IMPROVE ACCURACY AND REDUCE COSTS

Specim FX50 is a high-speed, accurate, and robust hyperspectral camera designed especially for industrial environments. It operates on the MWIR region and can be used, for example, to sort black plastics, analyze hydrocarbons and minerals, and detect contamination on metal surfaces quickly and reliably.

FEATURES

- Spectral range of 2.7 – 5.3 μm
- High spatial resolution of 640 pixels
- 1300:1 SNR for accurate classification
- High image speed of 377 frames per second
- Temperature stabilized optics
- Built-in image correction
- Unified spectral calibration between units
- GigE Vision standard interface
- Simple integration to industrial environments
- Optimized thermal management
- Fast application creation with the SpecimONE platform
- Compliances: CE, RoHS

SPECTRAL RESPONSE

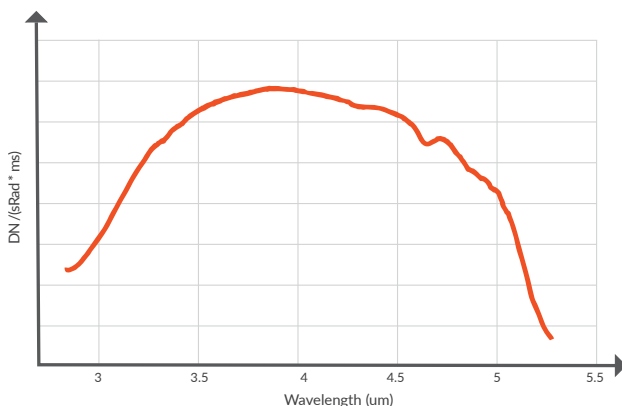

DIMENSIONS

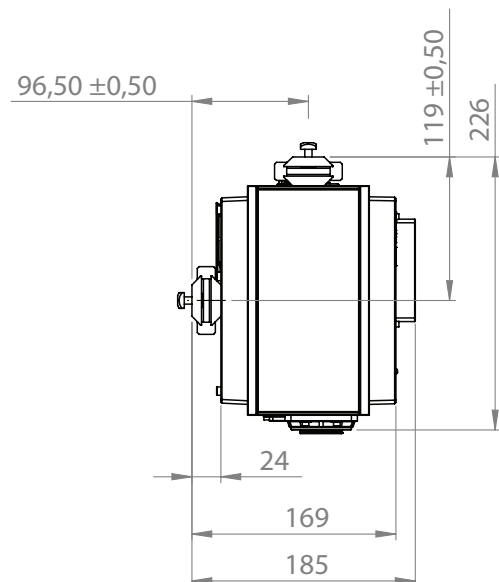
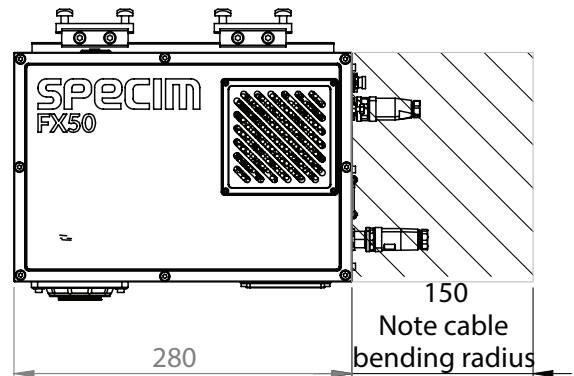

Learn more:



High-speed spectral camera FX50

Spectral Range	2.7 - 5.3 μm	
Spectral resolution (FWHM)	35 nm	
Spectral sampling/pixel	8.44 nm	Without binning
Spectral bands	154	With default binning 2x1
Numerical aperture	2.0	
Optics magnification	0.5	
Effective pixel size	30 μm	At fore lens image plane
Effective slit width	104 μm	At fore lens image plane
Effective slit length	19.2 mm	At fore lens image plane
Dynamic Range	2000:1 (1.5ms); 5000:1 (0.2ms)	Maximum true signal / dark noise
Max SNR	1300:1 (1.5ms); 1800:1 (0.2ms)	Maximum true signal / signal noise
Spatial samples	640	
Bit depth	16	
Maximum frame rate	377 fps	Full image with default binning
Binning	1,2,4 spectral and spatial	Default: 2 spectral x 1 spatial
ROI	Freely selectable multiple bands of interest	Minimum height of ROI is two 1-binned rows. Maximum frame rate is determined by total number of rows between first row of first mROI and last row of last mROI – not the total number of rows included in the mROI's.
Pixel operability	Number of operable pixels >99.6%	
Image corrections	Non uniformity correction Bad pixel replacement Automatic Image Enhancement (AIE)	One point NUC AIE: Unified spectral calibration + corrected smile and keystone aberrations
Sensor material	MCT	
Integrated cooler	Stirling	
Full well capacity	5.0 Me- (IWR), 6.36 Me- (ITR)	
Read-out modes	IWR / ITR	
Optics temperature	TEC-stabilized	Default is 20 degrees Celsius
Lens mount	Custom mount	
Fore lens options	OLEM43, OLEM23, OLEM17	
Field of view	24 deg, 45 deg, 60 deg	
Camera digital data output/control interface	GigE Vision, Custom ethernet	
Camera control protocols	GenICam, JSON-RPC	
Power input	24 V DC	
Power consumption	Max 90 W Typical 40 W	During simultaneous cool-down of optics and detector
Connectors	Ethernet Aux Power Trig In Trig Out	
IP	IP40	
Dimensions (L x W x H)	280 x 202 x 161 mm	Mounting surface option on two sides. The mounting kit adds a 24 mm distance on the mounting side.
Weight	7.5kg +/-10%	
Storage temperature	-20 ... +50 °C	
Operating temperature	+5 ... +40 °C	
Relative humidity	5% – 95% (non-condensing)	