

OXFORD
INSTRUMENTS

Andor CB2 Series

High resolution, high speed & UV-Vis sCMOS

Adaptive optics | Semiconductors | Life science
Low-mag microscopy | Ion flux imaging | Quantum computing

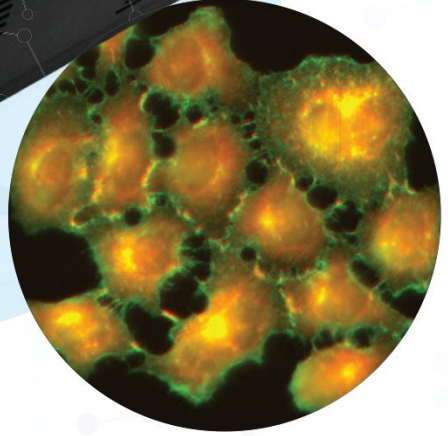
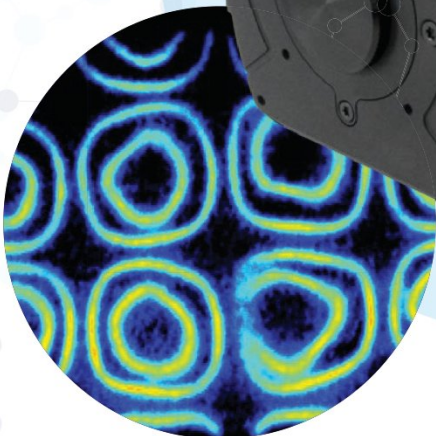
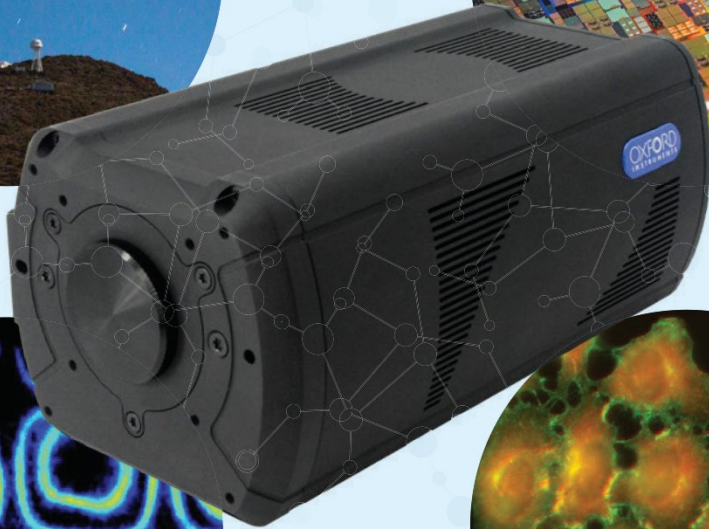

www.oxinst.com

Introducing the CB2 series

CB2 is an ultra-high performance scientific camera integrating Sony CMOS sensors specifically designed for research and applications requiring flexibility, speed and low noise. The CB2 series offers a spectral sensitivity from 200 to 1000 nm with resolutions ranging from 0.5 MP to 24.5 MP. Its internal hydraulic cooling enables the study of phenomena in the most light-starved conditions.



CB2 High Res

Featuring a 24.5 MP back-illuminated sensor for exceptional detail and long exposure performance with 2x2 on chip binning for improved signal to noise ratio. Perfect for applications that require a low magnification objective lens without compromising resolution.



CB2 High Speed

Optimised for rapid frame rates up to 1594 fps with resolutions ranging from 0.5 to 7.1 MP, this camera is perfect for speed-critical experiments.



CB2 UV

Specially optimised for ultraviolet imaging (200–400 nm), with quantum efficiency above 40% at 300 nm and high frame rates up to 194 fps. CB2 UV enables the study of very faint signal thanks to its extremely low dark current.



High resolution	High speed: three sensor options	UV optimised
Back-illuminated sensor	Front-illuminated sensor	Back-illuminated sensor
Low dark current sCMOS		
CoaXPress 2.0 or GigE interfaces		
Low temperature qualified		
Water (-40°C) and air cooling (-5°C)		

Key Common Features Specific Features

Andor CB2 series common features

Low dark current sCMOS	CB2 uses sensor cooling down to -40°C for minimisation of dark current. Combined with low amplifier glow from stacked chip design this allows access to longer exposures, up to several hours. This broadens application flexibility, and is therefore ideal for long exposure luminescence measurements and astro-photometry.
Selectable readout speeds	8-bits, 10-bits, 12-bits standard. HDR mode available as 14-bits for High Speed and 16-bits for High Res/UV. Choosing a pixel format is a trade-off between maximum achievable frame rate and dynamic range. Refer to pages 13 to 17 for specific frame rate tables.
Adjustable gain	Default options for selection of high (High Speed model only) or low sensitivity allows easy adjustment for sensitivity, or extended dynamic range. In addition, advanced users can fine tune sensitivity and dynamic range to suit their specific requirements using 24 dB analogue amplification gain and an additional 24 dB of digital amplification gain.
Region of interest (ROI) and multi-windowing	User-selectable regions of interest allow cropped sensor operation to boost frame rates, while multiple regions of interest can also be set to enhance application possibilities.
Compact design	CB2 packages a large area sensor, thermoelectric and liquid cooling and multiple connectivity options within a space efficient design, keeping the overall size of the camera to a minimum (LxWxH (in mm) : 183.7 (CXP) - 180.4 (GigE) x93 x 77.5). CB2 weighs 1.3 kg.
High speed data interface options	CB2 supports high data outputs with high-speed data interface options. CoaXPress provides stable, low latency performance and GigE offers a user-friendly interface over longer distances. CB2 supports GigE Vision and is compliant with GenICam standards.
On-chip 2x2 binning	CB2 features on-chip 2x2 binning for High Speed 7.1, UV and High Res sensors. This enables quadrupling the pixel area without increasing the number of readouts, improving signal-to-noise ratios and maximum achievable frame rates.

Andor CB2 High Res

Lens mount	The camera has C-mount native interface. However, for configurations which require a large optical aperture, a TFL-mount can be provided upon request.
High resolution sensor format	CB2 offers a 24.5 Megapixel array and small 2.74 µm pixel size, to image much wider areas at lower magnifications with full resolution.

Andor CB2 High Speed

Flexible resolution sensor format	CB2 High Speed offers 0.5, 1.7 and 7.1 Megapixels array and a pixel size of 4.5 or 9 µm, to record over a chosen area and resolution.
-----------------------------------	---

Andor CB2 UV

Enhanced quantum efficiency in the UV	Thanks to its back-illuminated structure and UV-optimised optical components to ensure high transmission of UV light, CB2 UV delivers exceptional spectral sensitivity in the 200-400 nm range.
Parasitic light sensitivity (PLS) corrections	Global shutter is a useful feature for applications requiring fast imaging. However, it makes the sensor prone to parasitic light sensitivity that appears as an intensity gradient on the image. CB2 UV handles this effect thanks to its integrated non-uniformity corrections.

Common features

High dynamic range

EXTENDED
DYNAMIC RANGE



The **16-bit** (UV and High Res) and **14-bit** (High Speed) HDR mode, use on-chip dual-amplifier design, meaning the whole photometric range, from the noise floor up to the saturation limit, can be captured with one image.

Combine with fast image stacking (accumulation) to extend dynamic range even further.

Connectivity

The CB2 Series supports the high data output with high-speed data interface options. CoaXPress provides stable, low latency performance and GigE offers a user-friendly interface over longer distances. The camera supports GigE Vision and is compliant with GenICam standards.



Global shutter



In global shutter, all pixels begin to expose simultaneously. At the end of the defined exposure period, each pixel transfers charge simultaneously to its readout node from which readout occurs 'behind the scenes'. Global shutter is often referred to

as 'SnapShot' exposure. It is ideal for imaging of fast processes without risk of spatial distortion and is also the most efficient means of imaging when peripheral equipment needs to be moved between exposures, as is often the case in fluorescence microscopy.

Low maintenance imaging



Applications that involve frequent cycling of mechanical shutters, such as large sky surveys or x-ray tomography, require routine shutter replacements and associated down time. CB2

sCMOS offers on-sensor electronic global shutter, thus overcoming the need for mechanical shutters. Furthermore, CB2 is operable down to -40°C ambient, ideal for observing at high altitudes and under extreme temperatures.

High speed



Delivering up to 1594 fps in 8-bit and 509 fps in HDR, and much faster still with Region of Interest (ROI) and/or pixel binning. CB2 can measure variability across a wide range of timescales, ideal for ion flux

microscopy, cell motility, wavefront sensing, imaging rapid celestial changes and fast measurements of quantum gas dynamics. Furthermore, the negligible readout time of a high-res sensor vastly exceeds that of CCDs, ideal for astro-photometry with minimal dead time between exposures.

Low noise



The massively parallel readout architecture and optimal pixel design enables CB2 to deliver very low readout noise performance at 1.4 to 2.6 e^{-} , depending on the sensor, while still achieving maximum readout speed and full dynamic range. Ideal for live cell microscopy with minimal phototoxicity or photobleaching, photometric and astrometric measurements with high dynamic range, and quantum gas fluorescence measurements of low atom numbers.

Long exposures



CB2 uses sensor cooling down to -40°C for minimisation of dark current. Combined with low amplifier glow from stacked chip design this allows access to longer exposures, up to several hours.

This broadens the application flexibility of this model, making it ideal for long exposure luminescence measurements and astro-photometry.

On-chip binning

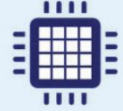

CB2 HR, UV and the 7.1 MP version of the CB2 HS series integrate Sony sensors with on-chip **2x2 binning** capabilities, using floating diffusion (also called charge-domain) binning. It allows the sensor to quadruple the pixel area without quadrupling readout noise, yielding a very significant increase in signal-to-noise ratio (SNR). This inherent optical flexibility significantly expands the range of applications these cameras can be used for.

HS

High speed

CB2 High Speed is a camera focusing on applications where speed is crucial. Based on sensors from the Sony Pregius family, the camera offers three resolutions: 0.5, 1.7 and 7.1 MP. The camera boosts its sensor to its limit achieving a frame rate up to 1595 fps. Thanks to its global shutter, fast events will appear crystal clear on the image.

UV

Blue / UV enhanced QE

CB2 UV is optimised for the 200 – 400 nm wavelength range. Its back-illuminated sCMOS sensor achieves a quantum efficiency **higher than 40% at 300 nm**. The camera's window is also designed to offer maximum transmission in the UV spectrum.

HR

High resolution

The CB2 High Res integrates the latest generation of sensors from Sony. Boasting an ultra-high resolution of 24.5 Megapixels (5328 x 4608), it captures wide fields of view with stunning precision, without sacrificing detail. Each pixel measures just $2.74\ \mu\text{m}$, enabling the sensor to reveal even the most minute features with remarkable sharpness. Moreover, the sensor's advanced design minimises noise and maximises dynamic range, ensuring that high-resolution doesn't come at the expense of image quality.



Life science applications

LUMINESCENCE **HR**

Bioluminescence forms the basis of many methods used in biological research. It is used in studies of gene transcription, protein expression, signalling pathways, circadian rhythms, through to cell viability. The signals involved in luminescence are typically weaker than those of fluorescence, so signal collection must be extended from many seconds to minutes. At such long exposures, it is thermal noise of the detector that sets the detection limit. Until now CCDs were favoured for long exposure applications such as luminescence, but CB2 High Res offers a cost-effective alternative because the dark current of CB2 High Res approaches that of CCDs.

IMAGE LARGE SAMPLES AT SPEED **HR**

Imaging at lower magnifications can provide significant boosts to throughput and productivity, as more information may be obtained in each image. However typical sCMOS cameras have a 6.5 μm pixel size which restricts their use to magnifications of 40x and above. While sCMOS cameras are available with smaller pixel sizes, they lack the necessary sensitivity. Andor's new CB2 High Res is a sensitive back-illuminated sCMOS camera with a small 2.74 μm native pixel size. Using 10x and 20x objectives, up to 4x more area can be captured compared to using 40x, while maintaining detail and sensitivity. By using the unique on-chip binning, the CB2 High Res can be set to an effective pixel size of 5.48 μm while improving signal-to-noise ratio.

HIGH THROUGHPUT SCREENING **HS**

At the interface between biochemistry, genomics, proteomics and pharmacology, high throughput screening (HCS) is a method that allows testing of thousands to millions of cells or chemicals. It is a useful technique for drug discovery. CB2 High Speed can be integrated in systems bringing a variety of resolutions and pixel sizes whilst operating at high speed and preserving a low noise.

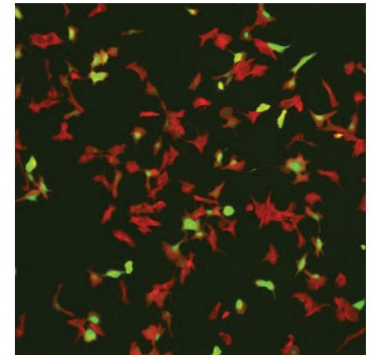

ION IMAGING**HS****HR**

Ions such as Calcium and Magnesium serve as vital co-factors for processes within cells. The dynamics and localisation of specific ions within living cells are therefore of interest to many studies, from the fundamentals of the cell machinery itself, to various disease states. Ion imaging has been made possible by development of various fluorescent dyes, and genetically encoded proteins that respond to ion concentration. To image calcium sparks and waves a fast and sensitive sensor is vital. CB2 combines a sensitive global shutter sensor with exceptional imaging speeds achieving true temporal accuracy across the full field of view.

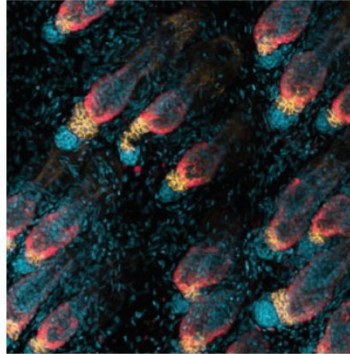
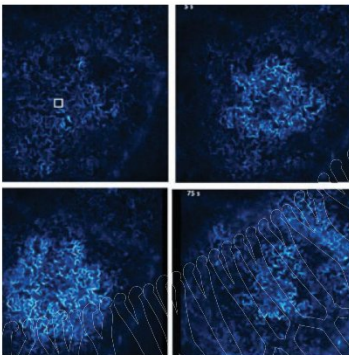
**CELL MOTILITY****HS****HR**

Cell motility covers many aspects of cellular processes. For single cellular organisms this can include chemotaxis of bacteria towards sources of food, or movement away from sources of harm. For multicellular organisms, cell motility is vital during development as differentiated cells migrate and organise to form tissues and organs. It is also important for cellular repair, or for cancer, when the normal processes are overridden. CB2 allows for the study of hundreds to thousands of cells without losing resolution or stitching images. In combination with low readout noise and on-chip binning to study cells with weak fluorescence signals.

DIGITAL HOLOGRAPHIC MICROSCOPY**HS****HR**

Label-free imaging techniques such as Digital Holographic Microscopy (DHM) and Quantum Phase Imaging (QPI) require low-noise, high-resolution sensors capable of capturing optical path length variations with high fidelity. Thanks to its resolution up to 7.1 Megapixels, high speed and global shutter, the CB2 High Speed meets these requirements. Its excellent linearity, low temporal noise will ensure precise phase reconstruction over time. The camera is the perfect tool for dynamic studies of live cells, growth, mitosis, morphological changes, without the need to use a dye and avoiding phototoxicity. This makes it ideal for long term and non-invasive analysis.

Physical science applications

LARGE SKY SURVEYS (ASTRONOMY)

HR

Several strands of astronomy require constant survey of large areas of the sky, monitoring for photometric or astrometric variability. This can encompass Space Domain Awareness, Exoplanet Discovery and Near-Earth Object (NEO) detection.

The large field of view, high resolution and high sensitivity of CB2 High Res means it is well suited to such challenges, either directly visualised or by occultation. Deep cooling and associated dark current minimisation, alongside the low amplifier glow of the stacked back-illuminated sensor, complements usage over a wide exposure range. Fast sensor readout means minimal deadtime between consecutive exposures and minimal photon wastage, whereas the global shutter is ideal for spatially referencing moving objects against star backgrounds with temporal accuracy. Lack of mechanical shutter means shutter lifetime is not an issue, reducing the downtime of cameras in remote observing locations. The on-chip 2x2 pixel binning flexibility makes CB2 High Res more optically adaptable to a range of telescopes.

ADAPTIVE OPTICS / LASER GUIDE STARS

HS

On one hand, adaptive optics systems rely on fast and precise feedback loops to correct for atmospheric turbulences. On the other hand, Laser Guide Stars (LGS) require sensitive and high-speed sensors to track wavefront distortions in real time. The CB2 High Speed is engineered to meet these demands. The camera delivers high frame rates up to 1595 fps (full resolution) combined with a global shutter to avoid any motion-induced distortion and very low readout noise. In addition, the CB2 High Speed offers an optimised quantum efficiency at 589 nm that is the sodium excitation peak for artificial stars. The CB2 High Speed supports CoaXPress and GigE Vision interfaces, enabling precise triggering, high-throughput data acquisition over long distances and simple integration into existing adaptive optics systems.

QUANTUM ION TRAP & NEUTRAL ATOM

HS

HR

CB2 can be readily integrated into optical systems for imaging arrays of ultracold trapped ions or neutral atoms in quantum computing systems. The low noise, good response in the blue wavelength range and rapid frame rate of CB2 (especially under ROI), is ideal for fast and continuous dynamic studies of trapped species. Global shutter ensures fast purging of unwanted 'pre-acquisition' signal and low latency data transfer compliments well into feedback loop systems.



TOMOGRAPHY (X-RAY OR NEUTRON)**HS****HR**

For high throughput 3D tomography, CB2 High Res and High Speed models, feature low noise and fast readout presenting a superb solution. Lens/scintillator coupled tomography using CB2 High Res and High Speed enables reconstruction of large objects without sacrificing resolution and clarity. Lack of mechanical shutter means shutter lifetime is not an issue, reducing downtime.

FLUID DYNAMICS (PIV)**HS****HR**

CB2 High Res and High Speed can be used with the Particle Imaging Velocimetry (PIV) technique for flow visualisation. Temporal resolution between image pairs is a key requirement of this approach and the global shutter mode of this camera can be harnessed to deliver a short electronic inter-frame gap. Note that the shortest interframe gap for CB2 High Res is 88 μ s. For shorter interframe gaps, it is recommended to use the [Andor ZL41 Wave 5.5](#).

**MICROFLUIDICS****HS****HR**

CB2 High Speed and High Res are well suited to image fast moving fluids through microfluidics channels. Its fast speed associated with its global shutter is an asset to reveal rapid and transient phenomena. Very often, only a small window of the sample needs to be captured. Making profit of the region of interest cropping, one can acquire a substantial number of images per second and transfer them with minimal latency. Thanks to its C-mount and optional TFL-mount, CB2 is adapted to most microscopes.

CB2 UV applications

SEMICONDUCTOR & PHOTOMASK INSPECTION

Ideal for detecting defects and structural variations with sub-micron resolution. Its global shutter combined with its very low readout noise ensure high-contrast and distortion free imaging of fast-moving wafers on a conveyor belt. Whether it is for photoresist inspection, overlay metrology or even process uniformity analysis, CB2 UV is a strong ally for the semiconductor industry.

UV-SHIFTED ASTRONOMICAL OBJECTS

Hot stars, white dwarfs and ionised gas strongly emit in UV and therefore, CB2 UV is well suited for imaging these astronomical objects with appropriate optics. Its speed and low noise enables the observation of fast and transient phenomena such as flares, pulsars associated with gamma rays bursts.

GAS EMISSION MONITORING / ENVIRONMENT

Some gases like sulphur dioxide have a strong absorption in the UV spectrum. SO_2 is a toxic gas that needs to be monitored and is noxious for the environment. It is, for instance,

responsible for acid rain. Being able to remotely detect it and evaluate its quantity is a serious asset. Thanks to its enhanced quantum efficiency in the UV, CB2 UV enables remote monitoring of SO_2 under sunlight illumination.

QUANTUM ION TRAP & NEUTRAL ATOM

CB2 UV can be readily integrated into optical systems for imaging arrays of ultracold trapped ions or neutral atoms in quantum computing systems. The low noise, good blue wavelength response and rapid frame rate of CB2 UV (especially under ROI), is ideal for fast and continuous dynamic studies of trapped species. Global shutter ensures fast purging of unwanted 'pre-acquisition' signal and low latency data transfer compliments well into feedback loop systems.

PLASMA PHYSICS & COMBUSTION

Plasma often emit in deep UV to EUV depending on species, energy and confinement. Thanks to its high dynamic range (16-bits) fast readout and compatibility with optics designed for UV, CB2 offers a

more affordable and compact alternative to iCCDs. The CB2 UV possesses a great quantum efficiency in the 200-400 nm range. In combustion, CB2 UV facilitates the non-intrusive visualisation of flame fronts, ignition dynamics and turbulence behaviour by imaging UV-emitting radicals OH^* (~308 nm) and CH^* (~430 nm).

FORENSICS

UV imaging plays a valuable role in forensic science, especially in documentation and non-invasive detection of evidence. With its 8.1 MP resolution and great sensitivity in the UV / blue range, CB2 UV is capable of recording the most subtle details and its low noise will reveal even the most faint UV emissions. Whether it is trace chemicals, latent finger prints or other body fluids, CB2 UV will enable comparative and quantitative studies.

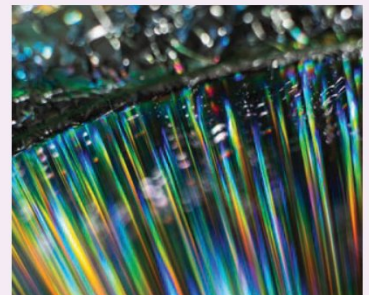

Please note when designing optical systems, it is crucial to consider the full optical path as many conventional optical materials are highly absorbent in the UV spectrum. Optics for UV imaging involve specialised materials and coatings.

Technical specifications

Specifications^{•1}

Sensor specifications	Andor CB2 High res	Andor CB2 High speed	Andor CB2 UV
Sensor type	Back-illuminated stacked sensor	Front-illuminated sensor	Back-illuminated sensor
Active pixels (W x H)	5328 x 4608 CMOS (24.5 MP)	3216x2208 1608x1104 816x624 CMOS (7.1 1.7 0.5 MP)	2848 x 2848 (8.1 MP)
Pixel size	2.74 μm	9 or 4.5 μm	2.74 μm
Pixel size with 2x2 on chip binning	5.48 μm	9 μm (7.1 model)	5.48 μm
Sensor size	19.3 mm diagonal 24.5 MP	17.6 17.6 9.2 mm diagonal 7.1 1.7 0.5 MP	11.2 mm diagonal 8.1 MP
Shutter architecture	Global shutter		
Maximum quantum efficiency	74 %	74 %	>40% at 300 nm (UV) & >70% at 500 nm (visible)
Readout noise (in 12 bits, 24 dB analogic gain at 50 μs)	1.4 e ⁻ • ^{•1}	1.4 e ⁻ 2.6 e ⁻ 2.6 e ⁻ • ^{•1} 7.1 1.7 0.5 MP	1.6 e ⁻ • ^{•1}
Air cooling	-5°C (@ +25°C ambient)	-5°C (@ +25°C ambient)	-5°C (@ +25°C ambient)
Liquid cooling		-20°C (@+25°C liquid) -40°C (@ +5°C liquid) • ^{•2}	
Dark current (@+20°C) (e ⁻ /p/s):	0.043	0.26 1.14 1.54 7.1 1.7 0.5 MP	0.014
Image full well capacity (lowest sensitivity available)	9.5 ke ⁻	23 ke ⁻ 94 ke ⁻ 94 ke ⁻ 7.1 1.7 0.5 MP	9.2 ke ⁻
Synchronization	Internal & External		
Analog gain quantization A/D	0 to 24 dB 8, 10, 12 bits		
Quantisation with HDR (High Dynamic Range)	16 bits	14 bits	16 bits
Binning	2x2 on-chip	2x2 (CB2 7.1F model only)	2x2 on-chip
Region of interest	Multiple simultaneous ROI supported		
Interface options	CoaXPress 2.0 High speed SFP+ 10 GigE interface with Ethernet (copper or fibre)		
Optical interface	C Mount + TFL Mount (Optional)	C Mount	C Mount

1. Figures are typical unless otherwise stated.

2. With lower temperatures of water/liquid coolant, please pay particular attention to the dew point, such that the relative humidity and temperature conditions of the environment do not result in condensation being formed on cold surfaces within the camera and risking damage to the camera electronics.

Want to see frame rates and QE data? Just click the tabs on the right to view data for the model that fits your needs.

HR

HS

UV



Frame rates CB2 High Res

CB2 High Resolution		Region of interest frame rate table in 8, 10, 12 and 16 HDR for CXP output			
		8-bit	10-bit	12-bit	16-bit (HDR)
Lines	16	2560	2458	1973	1366
	32	2370	2276	1812	1216
	64	2064	1982	1558	997
	128	1641	1576	1216	734
	256	1163	1117	845	480
	512	735	706	525	283
	624	633	608	450	240
	1104	397	381	280	145
	2208	214	205	149	76
	4608	106	102	74	37

CB2 High Resolution		Region of interest frame rate table in 8, 10, 12 and 16 HDR for GigE Vision output			
		8-bit	10-bit	12-bit	16-bit (HDR)
Lines	16	2560	2458	1973	1366
	32	2370	1790	1812	1216
	64	1636	1088	1184	891
	128	1017	679	726	566
	256	622	414	434	340
	512	361	241	248	192
	624	306	204	209	161
	1104	186	124	126	96
	2208	98	65	66	50
	4608	48	32	32	24

CB2 High Resolution	CoaXPress camera specifications (4 ports)		GigE Vision camera specifications (1 port)	
Maximum speed in full frame fps	8-bit	106 fps	8-bit	48 fps
	10-bit	102 fps	10-bit	32 fps
	12-bit	74 fps	12-bit	32 fps
	16-bit (HDR)	37 fps	16-bit (HDR)	24 fps
Maximum speed in 2x2 binning full frame	8-bit	386 fps	8-bit	188 fps
	10-bit	361 fps	10-bit	125 fps
	12-bit	283 fps	12-bit	129 fps
	16-bit (HDR)	N/A	16-bit (HDR)	N/A
Minimum integration time	8-bit	4,412 μ s	8-bit	6,769 μ s
	10-bit	4,496 μ s	10-bit	8,911 μ s
	12-bit	5,274 μ s	12-bit	8,911 μ s
	16-bit (HDR)	5,274 μ s	16-bit (HDR)	6,783 μ s

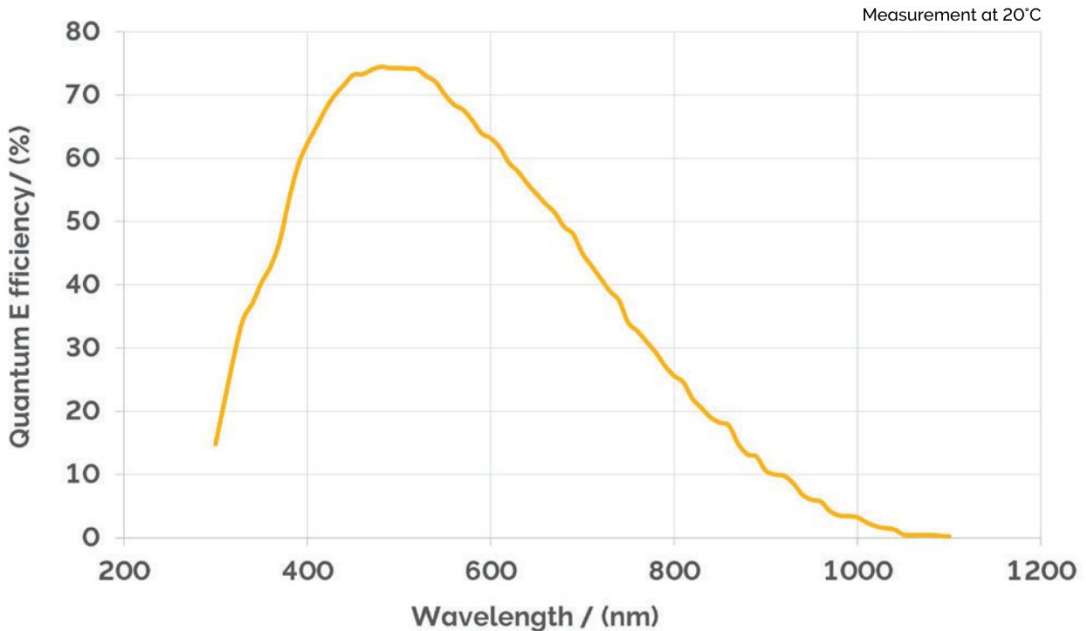



Frame rates CB2 High Speed

Region of interest frame rate table in 8, 10, 12 and 14 HDR for CXP output													
CB2 High Speed	CB2 7.1F	CB2 1.7F	CB2 0.5F	CB2 7.1F	CB2 1.7F	CB2 0.5F	CB2 7.1F	CB2 1.7F	CB2 0.5F	CB2 7.1F	CB2 1.7F	CB2 0.5F	
	8-bit			10-bit			12-bit			14-bit (HDR)			
Lines	16	3545	3997	7366	3118	3639	6696	2864	3457	5150	2416	3043	4377
	32	3171	3721	6725	2772	3370	6114	2494	3169	4608	1933	2623	3648
	64	2620	3270	5729	2268	2935	5208	1983	2716	3806	1381	2056	2736
	128	1944	2632	4419	1663	2333	4017	1406	2113	2824	878	1435	1824
	256	1282	1893	3033	1084	1654	2757	889	1463	1862	508	895	1094
	512	762	1212	1863	639	1045	1694	512	905	1108	276	510	608
	624	648	1047	1594	542	900	1449	432	776	941	230	429	509
	1104	393	662	-	328	565	-	258	481	-	134	256	-
	2208	207	-	-	172	-	-	134	-	-	68	-	-

Region of interest frame rate table in 8, 10 / 10-bit packed, 12/ 12-bit packed and 14 HDR for GigE Vision output													
CB2 High Speed	CB2 7.1F	CB2 1.7F	CB2 0.5F	CB2 7.1F	CB2 1.7F	CB2 0.5F	CB2 7.1F	CB2 1.7F	CB2 0.5F	CB2 7.1F	CB2 1.7F	CB2 0.5F	
	8-bit			10-bit (10-bit packed)			12-bit (12-bit packed)			14-bit (HDR)			
Lines	16	3545	3997	7366	3118 (3118)	3639 (3639)	6696 (6696)	2864 (2864)	3457 (3457)	5150 (5150)	2416	3043	4377
	32	3171	3721	6725	2772 (2772)	3370 (3370)	6114 (6114)	2494 (2494)	3169 (3169)	4608 (4608)	1933	2623	3648
	64	2620	3270	5729	2268 (2268)	2935 (2935)	5208 (5208)	1983 (1983)	2716 (2716)	3806 (3806)	1381	2056	2736
	128	1944	2632	4419	1294 (1663)	2333 (2333)	4017 (4017)	1406 (1406)	2113 (2113)	2824 (2824)	878	1435	1824
	256	1282	1893	3033	681 (908)	1406 (1654)	2757 (2757)	720 (889)	1462 (1462)	1862 (1862)	508	895	1094
	512	695	1212	1863	353 (470)	715 (961)	1452 (1694)	364 (485)	736 (905)	1108 (1108)	276	510	608
	624	576	1047	1594	292 (389)	592 (792)	1196 (1449)	300 (400)	607 (776)	941 (941)	230	429	509
	1104	333	662	-	168 (223)	337 (450)	-	171 (227)	343 (458)	-	134	256	-
	2208	169	-	-	85 (113)	-	-	85 (114)	-	-	68	-	-

CB2 High Speed		CoaXPRESS camera specifications (4 ports)			GigE Vision camera specifications (1 port)			
		CB2 7.1F	CB2 1.7F	CB2 0.5F		CB2 7.1F	CB2 1.7F	CB2 0.5F
Maximum speed in full frame fps	8-bit	207	662	1594	8-bit	169	662	1564
	10-bit	172	565	1449	10-bit (10-bits packed)	85 (113)	337 (450)	1196 (1449)
	12-bit	134	481	941	12-bit (12-bits packed)	85 (114)	343 (458)	941 (941)
	14-bit (HDR)	68	256	509	14-bit (HDR)	68	256	509
Maximum speed in 2x2 binning full frame	8-bit	418	N/A	N/A	8-bit	418	N/A	N/A
	10-bit	387	N/A	N/A	10-bit (10-bits packed)	344 (387)	N/A	N/A
	12-bit	261	N/A	N/A	12-bit (12-bits packed)	261 (261)	N/A	N/A
	14-bit (HDR)	134	N/A	N/A	14-bit (HDR)	134	N/A	N/A
Minimum integration time	8-bit	7.07	6.16	5.80	8-bit	7.53	6.16	5.80
	10-bit	7.50	6.37	5.89	10-bit (10-bits packed)	10.06 (8.79)	7.30 (6.72)	6.07 (5.89)
	12-bit	8.23	6.64	6.42	12-bit (12-bits packed)	10.06 (8.79)	7.30 (6.72)	6.42 (6.42)
	14-bit (HDR)	8.23	6.64	6.42				

Measurement at 20°C

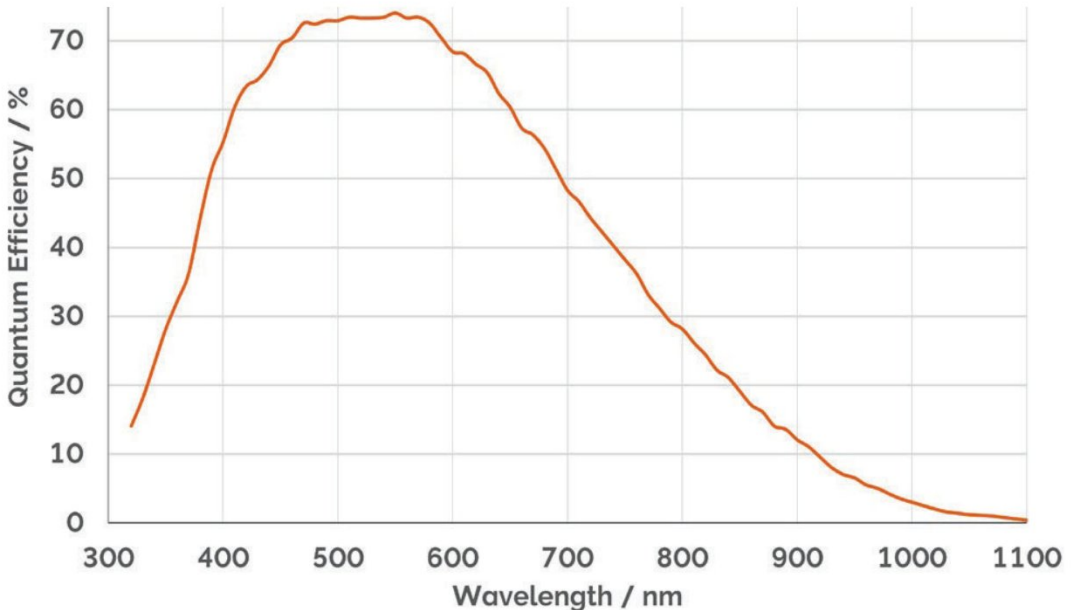

Frame rates CB2 UV

CB2 UV		Region of interest frame rate table in 8, 10, 12 and 16 HDR for CXP output			
		8-bit	10-bit	12-bit	16-bit (HDR)
Lines	16	2002	2303	1628	1221
	32	1901	2169	1526	1110
	64	1729	1944	1356	939
	128	1463	1609	1110	718
	256	1118	1197	814	488
	512	760	792	530	297
	624	667	689	460	254
	1104	437	444	294	156
	2208	243	244	160	83
	2848	194	193	127	65

CB2 UV		Region of interest frame rate table in 8, 10, 12 and 16 HDR for GigE Vision output					
		8-bit	10-bit	10-bit packed	12-bit	12-bit packed	16-bit (HDR)
Lines	16	2002	2303	2303	1628	1628	1221
	32	1901	2169	2169	1526	1526	1110
	64	1729	1697	1944	1356	1356	939
	128	1463	993	1321	1049	1110	718
	256	1074	584	777	609	809	488
	512	631	335	446	344	458	297
	624	539	284	378	290	387	254
	1104	333	172	230	175	233	156
	2208	179	91	121	91	122	83
	2848	140	71	95	72	96	24

CB2 UV	CoaXPress camera specifications (2 ports)		GigE Vision camera specifications (1 port)	
Maximum speed in full frame fps	8-bits	194	8-bits	140
	10-bits	193	10-bits (10-bits packed)	71 (95)
	12-bits	127	12-bits (12-bits packed)	72 (96)
	16-bits (HDR)	65	16-bits (HDR)	65
Maximum speed in 2x2 binning full frame	8-bits	653	8-bits	517
	10-bits	618	10-bits packed	349
	12-bits	450	12-bits packed	371
	16-bits (HDR)	N/A	16-bits (HDR)	N/A
Minimum integration time (µs)	8-bits	4.11	8-bits	4.73
	10-bits	4.14	10-bits (10-bits packed)	6.98 (5.85)
	12-bits	5.03	12-bits (12-bits packed)	6.98 (5.85)
	16-bits (HDR)	5.03	16-bits (HDR)	5.03

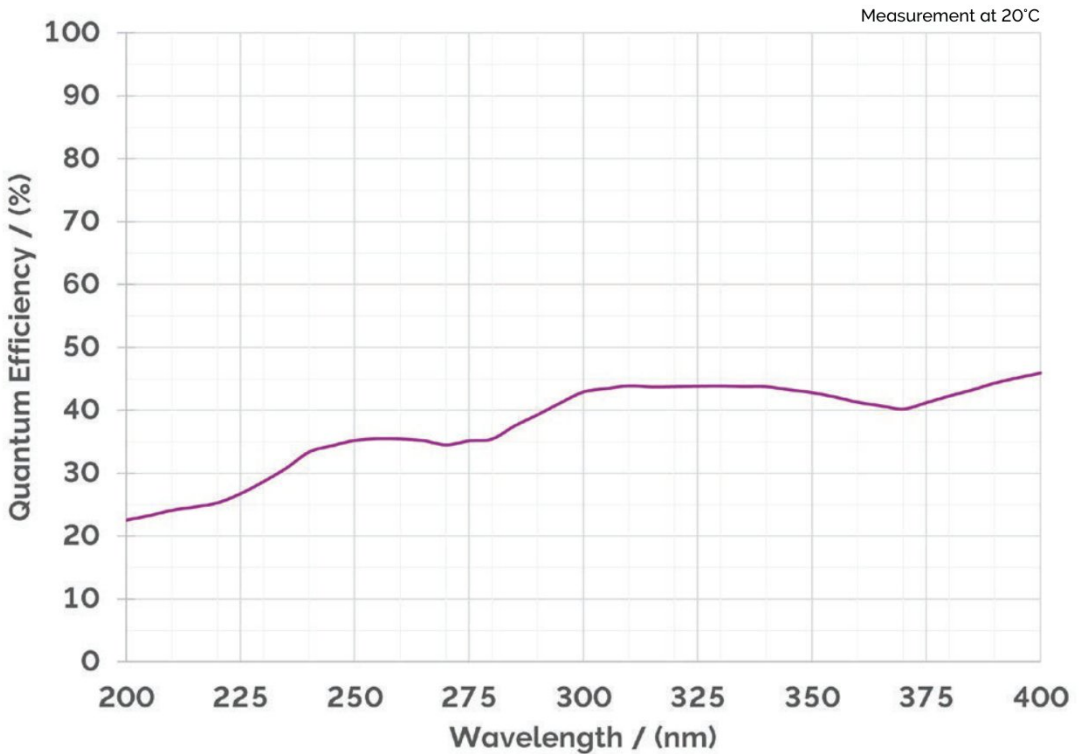

Product drawings

Dimensions in mm
 Air or liquid cooling
 Weight 1.3 kg

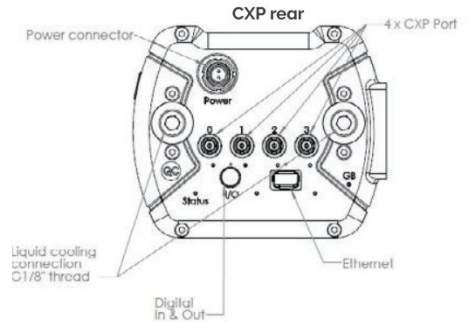
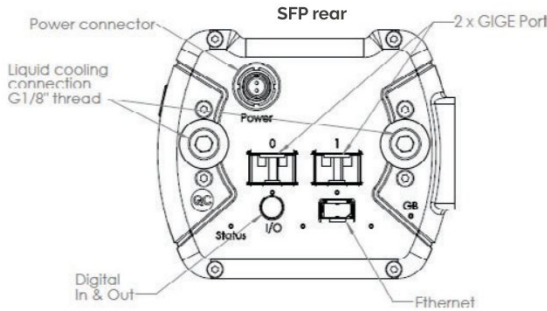
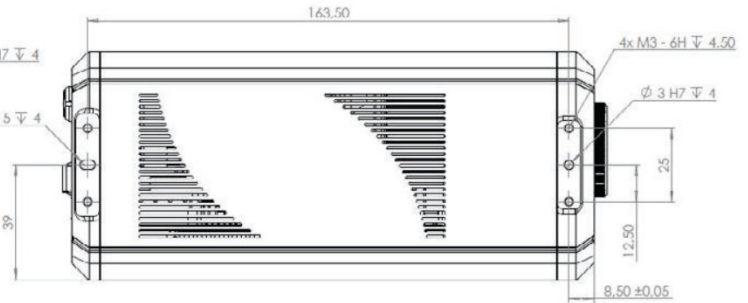
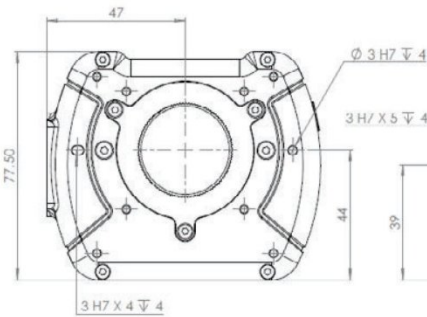
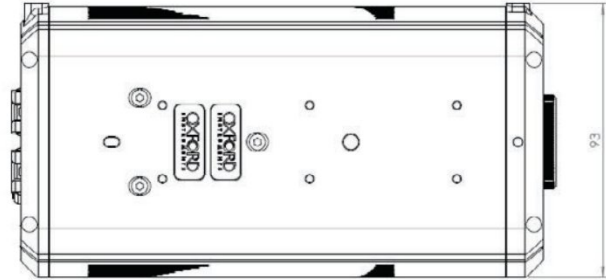
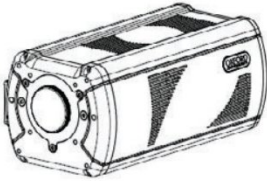

Items shipped with your camera:

- 1x Camera (model as ordered)
- 1x Power supply
- 1x Power supply cable
- 1x Quick start guide

Recommended computer requirements:

See [system requirements](#) for more information.

Operating and storage conditions

- Operating temperature: -40°C to +50°C
- Relative humidity: 95% (non-condensing)
- Storage temperature: -40°C to +70°C

Power requirements

- 100 - 240 VAC 50 - 60 Hz
- Max. power consumption: 60 W

Footnotes

1. Figures are typical unless otherwise stated.
2. With lower temperatures of water/liquid coolant, please pay particular attention to the dew point, such that the relative humidity and temperature conditions of the environment do not result in condensation being formed on cold surfaces within the camera and risking damage to the camera electronics.
3. Please note that our software and SDK support grabber cards from Euresys and Zebra (formerly Matrox). We recommend caution when using other grabber cards.

Creating the optimum product for you

Step 1. Select the camera type



Camera type

	Description	SFP	CXP
HR	CB2 24B: 5328 x 4608 monochrome CMOS camera, up to 106 fps	PAC-CB2-SFP-V24	PAC-CB2-CXP-V24
UV	CB2 UV: 2848 x 2848 monochrome CMOS camera, 127 fps (12-bits)	PAC-CB2-SFP-U81	PAC-CB2-CXP-U81
HS	CB2 7.1F: 3216 x 2208 monochrome CMOS camera, 207 fps	PAC-CB2-SFP-V71	PAC-CB2-CXP-V71
HS	CB2 1.7F: 1608 x 1104 monochrome CMOS camera, 662 fps	PAC-CB2-SFP-V17	PAC-CB2-CXP-V17
HS	CB2 0.5F: 816 x 624 monochrome CMOS camera, 1594 fps	PAC-CB2-SFP-V05	PAC-CB2-CXP-V05

Step 2. Select the required accessories

The part codes above **DO NOT** include grabber cards or cables. Please order either grabber kits or individual grabber cards and cables from the below accessory list, as required for either CoaXPress or GigE models. ^{•3}



Accessories

Acquisition accessories description	Order Code
Grabber kit quad CoaXPress 5 m (all included)	ACC-GRA-CXP-004
Grabber kit dual CoaXPress 5 m (all included - CB2 HS/UV only)	ACC-GRA-CXP-005
Grabber kit 10 GB GigE ethernet 10 m (all included)	ACC-GRA-10G-ETH-CB2
Grabber kit 10 GB GigE fibre 10 m (all included)	ACC-GRA-10G-FIB-CB2
Grabber quad CoaXPress Zebra	ACC-GRA-CXP-003
Grabber Duo CoaXPress Zebra (CB2 HS/UV only)	ACC-GRA-CXP-000
CoaXPress cables 10 m (2x required or x4 for CB2 HR)	ACC-CAB-CXP-000
CoaXPress cables 5 m (2x required or x4 for CB2 HR)	ACC-CAB-CXP-002
CoaXPress cables 3 m (2x required or x4 for CB2 HR)	ACC-CAB-CXP-001
Grabber SFP	ACC-GRA-SFP-000
Ethernet cables 10 m (2x required)	ACC-CAB-ETH-000
Fibre cables 10 m (2x required)	ACC-CAB-FIB-000
TFL mount	ACC-MNT-TFL-000
Cooling accessories description	Order Code
Cooling pack (chiller unit, connectors and hoses)	PAC-COO-200-000
Quick coupling set	ACC-QCS-CAM-001
Synchronise accessories description	Order Code
Pair of synchro cables 1 m	ACC-CAB-SYN-000
Pair of synchro cables 3 m	ACC-CAB-SYN-001

Step 3. Software



Software

Your product is provided with the following software:
Graphical User Interface: First Light Vision, µManager
Software Development Kit: (C, C++, C#, Python, LabVIEW, MATLAB)
 See [system requirements](#) for more information.

Order Today

Need more information? At Oxford Instruments we are committed to finding the correct solution for you. With a dedicated team of technical advisors, we are able to offer you one-to-one guidance and technical support on all products.

For a full listing of our local sales offices, please see: andor.oxinst.com/contact

Your regional sales partner:



Quantum Design GmbH

Breitwieserweg 9,
D-64319 Pfungstadt
+49 6157 80710-0
germany@qd-europe.com
www.qd-europe.com

Note

Oxford Instruments reserves the right to alter without notice the specification, design or conditions of supply of any product or service.

Original document in English.

Cover image credit, bottom right:
Image of HeLa cells by the CRCM
(Cancer Research Centre of
Marseille).