

ZL41 Wave sCMOS

Highly Flexible Workhorse Camera
for Physical Sciences

Key Specifications

- ✓ Up to 82% QE
- ✓ < 1 e- read noise
- ✓ Up to 100 fps
- ✓ 32-bit binning mode
- ✓ Spectroscopy modes
- ✓ Operate down to -20°C ambient

Key Applications

- ✓ Large sky surveys
- ✓ Bose Einstein Condensation
- ✓ Quantum computing
- ✓ Beam profiling & Fluid dynamics
- ✓ Speckle interferometry
- ✓ Wavefront sensing
- ✓ Multi-fibre spectroscopy

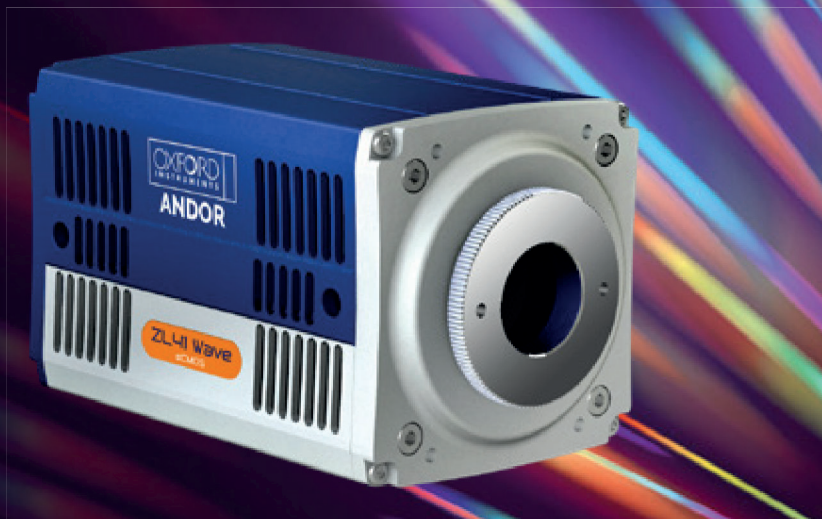

Introducing the ZL41 Wave family



Andor's ZL41 Wave physical sciences workhorse sCMOS camera platform delivers sheer excellence in **speed, sensitivity, dynamic range and resolution**, with comprehensive **imaging and spectroscopy** functionalities.

Building upon the strengths of the original Zyla sCMOS series, the **cost-effective, multi-functional, compact, thermoelectrically cooled** design of ZL41 Wave benefits from a reengineered and **enhanced sensor chamber** and is supported within a **wide range of physical science software environments**, integrating perfectly into any optical laboratory or observatory setting.

ZL41 Wave Features Specifically for Physical Sciences

NEW 32-bit binning mode	Access huge dynamic range through extensive pixel binning. User-selectable data bit-depth up to 32-bit, transmitted upstream over the camera interface.
Spectroscopy mode	On-head asymmetric pixel binning and multitrack. Spectroscopist-friendly spectra and multi-track data, prior to transfer through 10-tap or USB interface. Upstream data size reduction and easier user data processing.
Fast Spectroscopy: Up to 27,000 spectra/sec	Study of transient spectral phenomena with sub-millisecond time resolution
PIV capability (ZL41 Wave 5.5)	Perfect for fluid dynamics, Global Shutter mode of ZL41 Wave 5.5 facilitating image pair acquisition with an inter-frame gap of down to 100 ns.
NEW Operate down to -20°C ambient temp	Ideal for use at observatories under cold conditions.
Liquid/Water cooling (optional)	Access -10°C cooling (at any altitude) for reduced darkcurrent. Also recommended for extremely vibration-sensitive set-ups.
ZERO etaloning in the NIR	Front-illuminated sensor architecture, no unwanted signal modulation in the NIR compared to back-illuminated devices
GPU Express	Simplify and optimize data transfer from the camera - ideal for today's data intensive imaging experiments. Leverage CUDA-enabled NVidia GPU processing to accelerate the data acquisition pipeline.
Linux, Windows, LabView and MATLAB ready	Full and flexible SDK options for a wide variety of physical science laboratory and observatory uses.
NEW Python ready	Python wrapper integration and full supporting documentation in latest camera SDK helps integration and full control of custom-build systems.
NEW ASCOM, EPICS and Tango ready	Supported in open source software platforms. ASCOM astronomy instrument control standard; EPICS and Tango Lima used for hardware control at a number of particle accelerators and large scientific instruments facilities worldwide.

ZL41 Wave 4.2: Superior Sensitivity

ZL41 Wave 4.2 provides **exceptional sensitivity** from a combination of **82% QE** and very low **0.9 e⁻ read noise** from a **4.2 Megapixel** sensor. Ideal for pushing frame rates in light starved applications within astronomy, quantum imaging, quantum computing, spectroscopy and 3D-tomography fields.

ZL41 Wave 5.5: Global Shutter and Large Field of View

ZL41 Wave 5.5 is an **ideal workhorse camera**, a **highly cost-effective** and **flexible solution** that delivers a **superior field of view** from a **5.5 Megapixel sensor**. Furthermore, this camera offers 2-in-1 rolling and true global shutter functionality. Global shutter is key to techniques such as particle imaging velocimetry (PIV), astronomical object tracking and fluid dynamics..

Feature	Benefit
NEW Enhanced image quality	Updated QC processes ensure every ZL41 Wave delivers optimal image quality. Ultra-low Photon Response Non-Uniformity (PRNU) for clear, uniform images.
NEW Sensor chamber	An updated sensor chamber provides even greater long-term protection from condensation in high humidity environments (3 year chamber warranty).
5.5 and 4.2 megapixel formats	Sharp resolution over a large field of view. Ideal for astronomy, area scanning applications or multi-track spectroscopy.
QE _{max} boosted to 82%	Highest available photon capture efficiency across visible/NIR.
< 1 e ⁻ read noise	Noise floor down to 0.9 e ⁻ . Lower detection limit than any CCD.
100 fps (Camera Link)	ZL41 Wave offers '10-tap' Camera Link for maximum sustained frame rates.
Market leading USB 3.0 speed	ZL41 Wave delivers up to 53 fps full resolution. Follow dynamic processes with improved temporal resolution.
Extended dynamic range	Unique 'dual gain amplifier' sensor architecture offering dynamic range of 33,000:1. ZL41 can also be operated in single amplifier mode.
Unparalleled photometric accuracy	Better than 99.8% linearity provides market-leading quantitative measurement accuracy across the full dynamic range.
Hardware-generated timestamp	FPGA generated timestamp with 25 ns accuracy.
Compact and Light	Ideal for integration into space restrictive optical breadboard set-ups.

ZL41 Wave for Extended Dynamic Range



Andor's ZL41 Wave bundles multiple approaches to achieving extended dynamic range imaging and spectroscopy.

Dual Amplifiers (16-bit mode)

On-chip dual-amplifier design means the whole photometric range, from the noise floor up to the saturation limit, can be captured with one image. The wide dynamic range is complemented by enhanced on-head intelligence to deliver linearity > 99.8%, for unparalleled quantitative photometric accuracy across the full signal range.

32-bit binning mode

Many applications require pixel binning in order to (a) boost SNR via an expanded photon collection area (via the binned pixel area), and (b) further extend dynamic range through an increased pixel well depth (which scales linearly with the number of binned pixels). Vertical binning of pixels is also standard in spectroscopy mode.

The ZL41 Wave maintains dynamic range through extensive binning with a user-definable bit depth selection, which offers up to 32-bit upstream data packaging to overcome the limitation of standard 16-bit data transfer through the CameraLink or USB3 interface.

Fast stacking (accumulation) of images or spectra

The ZL41 Wave is exceptionally well suited to massively extending dynamic range through fast stacking of images or spectra. sCMOS technology is ideally suited to this approach as it is capable of very fast frame rates with an ultra-low read noise.

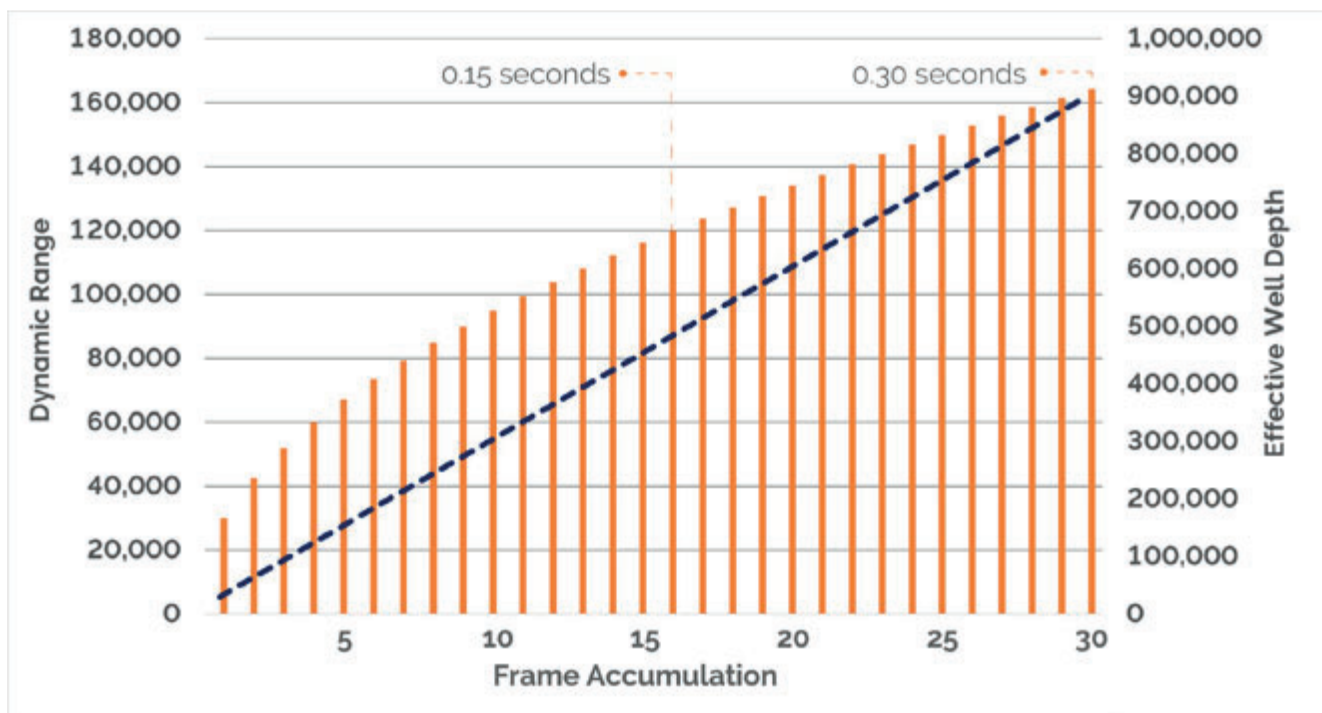

Dynamic Range and Effective Well Depth as a function of the number of stacked (accumulated) frames, plotted for ZL41 Wave. A Dynamic Range of 164,300:1, and a corresponding Effective Well Depth of 900,000 electrons can be reached with only 30 stacked frames. At maximum frame rate, this number of accumulated frames takes only 0.3 secs to acquire, achieving 3.3 fps. This capability is significant for a range of challenges across imaging and spectroscopic characterisations.



ZL41 Wave for Spectroscopy

ZL41 Wave is for fast spectroscopy applications, such as spectral mapping, fluorescence correlation spectroscopy or fast transient phenomena sampling, including fast chemical reaction monitoring. The multi-track spectral mode of ZL41 Wave is ideally suited to multi-fibre spectroscopy, allowing many points of a sample to be simultaneously and spectrally monitored with high data throughput. Furthermore, the high-QE front illuminated sensor structure means that ZL41 Wave can capture spectra with zero etaloning (also known as fringing) in the red/NIR, a phenomenon that can otherwise adversely affect back-illuminated sensors.

How the sCMOS sensor is used in the different modes

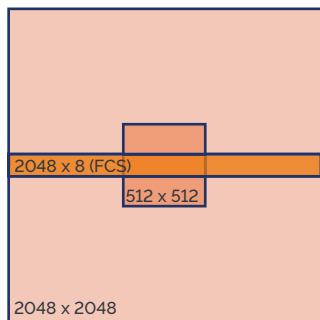

I **Imaging Mode**
The array size may be defined (includes FCS modes) for either resolution or maximum speed.

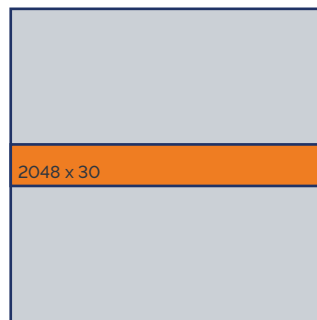

S **Spectroscopy Mode**
A vertically binned track is centred on the sensor enabling the maximum spectral rate to capture dynamic events.

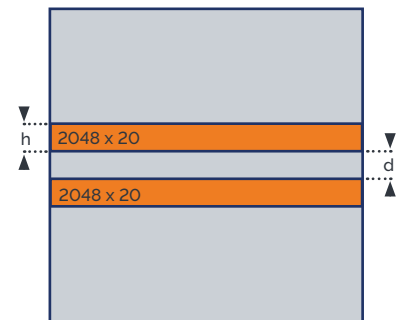

M **Multi-track Mode**
Up to 256 vertically binned tracks can be used for multi-track analysis without sacrificing speed.

S Spectroscopy Mode

Vertically binned tracks 12 & 16-bit

M Multi-track Mode

Vertically binned tracks 12 & 16-bit

Array Size (W x H)	ZL41 Wave 5.5 10-tap / USB 3.0		ZL41 Wave 4.2 10 tap/USB 3.0 Rolling Shutter*	Number of tracks (centred vertically)	Track height (h, pixels)	Tracks separation (d, pixels)	ZL41 Wave 5.5 10-tap / USB 3.0		ZL41 Wave 4.2 10-tap/USB 3.0 Rolling Shutter*
	Rolling Shutter*	Global Shutter**					Rolling Shutter*	Global Shutter**	
any x 8	27,057	4,008	26,041	2	12	12	6,012	1,967	5,787
any x 12	18,038	3,491	17,361	2	20	20	3,607	1,370	3,472
any x 16	13,528	3,092	13,020	2	154	77	557	265	536
any x 31	6,764	2,122	6,510	20	12	12	462	222	445
any x 77	2,705	1,093	2,604	20	20	20	277	135	267
any x 100	2,164	909	2,083	50	12	12	182	89	175
any x 128	1,691	736	1,627	50	20	20	109	54	105
any x 154	1,387	618	1,335	256	8	0	105	52	101
any x 462	466	224	448						
any x 512	422	203	406						
any x 1040	208	102	200						
any x 1080	200	98	192						
any x 2048	105	52	101						

* Overlap ON
** Overlap OFF

Key Features

Fast Frame Rate

ZL41 models read out a full frame in only 10 milliseconds, enabling 100 fps, and can measure dynamics across timescales ranging from milliseconds to tens of seconds. Ideal for measuring rapid photometric/astrometric variability and fast imaging of quantum phenomena.

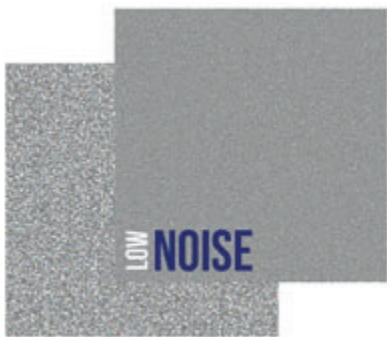

High Sensitivity

The parallel readout architecture and innovative pixel design enables ZL41 Wave to drive very low read noise performance of $< 1 e^-$, while still achieving maximum readout speed and full dynamic range. The ZL41 Wave 4.2 delivers a peak QE of 82%, with broad response across the UV-VIS-NIR range, with zero etaloning in the near infra-red.

6.5 μm Pixel

The 6.5 μm pixel sizes of ZL41 models offer a solution to more closely resolution match the camera to the specific optical configuration. Pixel binning with 32-bit digitization offers further usage flexibility.

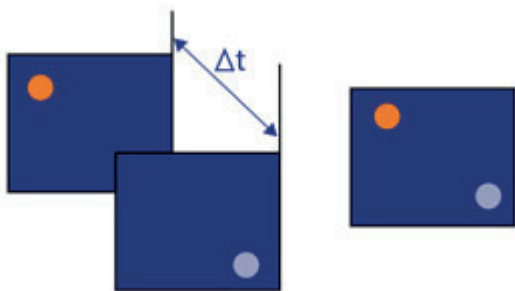
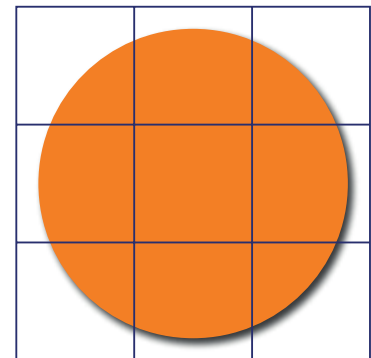

PIV Capability

The ZL41 Wave 5.5 model is well suited to the Particle Imaging Velocimetry (PIV) technique for flow visualisation. Temporal resolution between image pairs is a key requirement of this approach and the global shutter mode of this camera can be harnessed to deliver an optical inter-frame gap of down to ~ 100 ns.

Enhanced Sensor Enclosure

Building upon the strengths of the original Zyla sCMOS camera series, ZL41 Wave benefits from an updated sensor chamber design and manufacture process, as well as a comprehensive seal test procedure, providing even greater long-term protection from condensation ingress in high humidity environments (3 year chamber warranty).

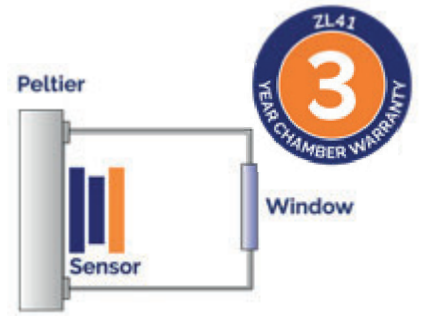

No Mechanical Shutter

Applications that involve frequent cycling of mechanical shutters, such as X-Ray Tomography or Large Sky Surveys, require routine shutter replacements and associated down time. ZL41 Wave offers on-sensor Rolling and Global electronic shutter, thus overcoming the need for mechanical shutters. This furthermore avoids the exposure gradient effects associated with of iris shutter, thus much better for accurate photometry.



Comprehensive Software Solutions

ZL41 Wave offers an extensive portfolio of software compatibility solutions, assembled with physical science users in mind. Our accessible sCMOS SDK (SDK3), with full documentation, is available with Python, LabView and MATLAB wrappers. We also offer support for open source platforms such as ASCOM, EPICS and Tango Lima.

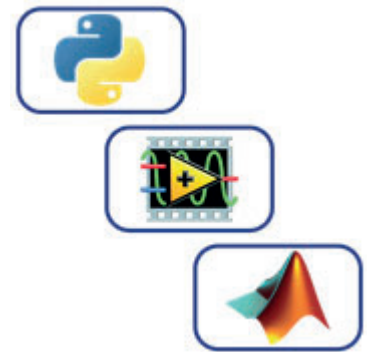

Low Maintenance Astronomy

ZL41 Wave has been tested down to -20°C , suited for use at observatories where night observations routinely occur in sub-zero ambient conditions.



Application Focus

Large Sky Surveys

Large arrays of cost-effective, high performance ZL41 Wave cameras can be very effectively deployed to continuously and quantitatively monitor huge sections of the night sky, looking for photometric or astrometric changes or occultations across a range of time-resolutions. Whether used for Near-Earth Object (NEO) detection, Orbital Debris tracking or Exoplanet hunting, ZL41 Wave 4.2 offers highest sensitivity, facilitating detection of smaller objects or minor occultations. Alternatively, the ZL41 Wave 5.5 model offers true global shutter, which can be important in the context of tracking moving objects relative to a reference background of stars.

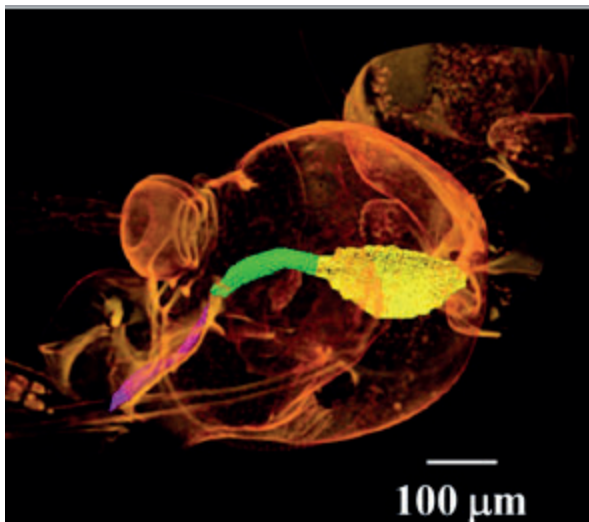
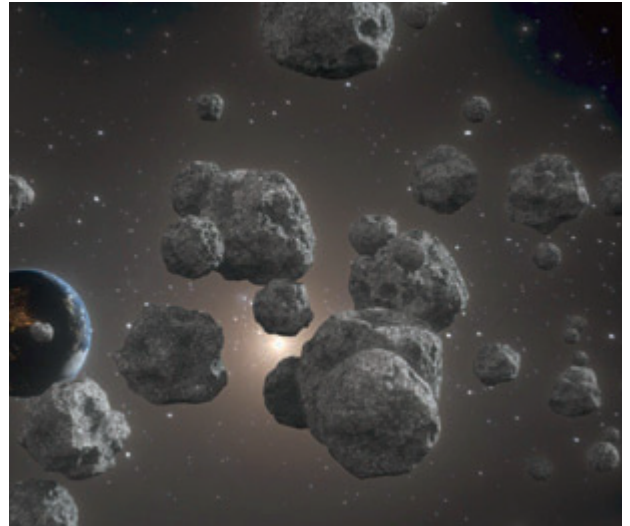

X-Ray or Neutron Tomography

For high throughput 3D tomography (or even 4D: 3D + time), the high-resolution ZL41 Wave models, featuring low noise, fast readout and high QE, present a superb solution. Lens/scintillator coupled tomography using ZL41 enables reconstruction of large objects without sacrificing resolution and clarity. Lack of mechanical shutter means shutter lifetime is not an issue, reducing downtime.

Quantum Imaging

ZL41 Wave can be readily integrated into optical systems for imaging ultracold quantum gases, such as Bose Einstein Condensates or even single trapped ion/atom fluorescence studies with continuous (i.e. non-burst) frame rates of more than 26,000 fps.

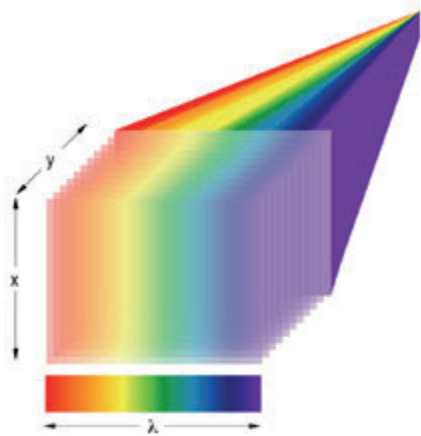

Hyperspectral

ZL41 Wave is ideal for fast, high dynamic range spectral imaging, either: (a) hyperspectral configurations (push-broom or otherwise), enabling full data cubes to be rapidly acquired, or (b) high density multi-track spectroscopy at fast spectral rates and/or very high dynamic range. For example, ZL41 Wave 4.2 can acquire 20 spectral tracks (each 12 pixels high) at 445 fps and can acquire a single spectrum at up to 26,041 fps.

Resolution Enhancement

Lucky/Speckle Imaging – ZL41 Wave can be used for the 'Atmospheric Freezing' techniques of Lucky and Speckle Imaging, enabling resolution enhancement of ground-based astronomy. The 100 fps (full array) with 100% duty cycle means that enhanced resolution images can be generated within a few seconds of acquisition.

Wavefront Sensing – ZL41 Wave is a fast wavefront sensor for Adaptive Optics, for example a 128x128 Region of Interest of ZL41 Wave 4.2 yielding 1627 fps.



Meet the Extended sCMOS Family for Physical Sciences

Marana sCMOS

Back-illuminated, deep cooled sCMOS
Ultimate sensitivity and large FoV

- ✓ Near earth object (NEO) detection
- ✓ Space debris tracking
- ✓ Solar astronomy
- ✓ Fast time resolution astrophysics
- ✓ Wafer inspection

[Read more](#)



ZL41 Wave

For physical imaging, astronomy
and spectroscopy

3D flow field study by PIV (using 4x cameras),
courtesy of Gioacchino Cafiero, Universit' a di
Napoli Federico II.

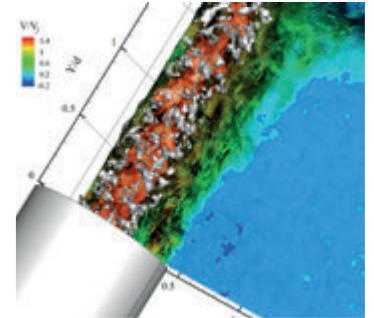

iStar sCMOS

For nanosecond gated imaging and
spectroscopy

- ✓ Quantum physics
- ✓ Plasma diagnostics
- ✓ Flow/spray/combustion processes study
- ✓ Planar Laser-Induced Fluorescence (PLIF)
- ✓ Time-resolved luminescence

[Read more](#)

Plasma bullet time-dynamics studies, courtesy
of Jérôme Bredin at York
Plasma Institute.

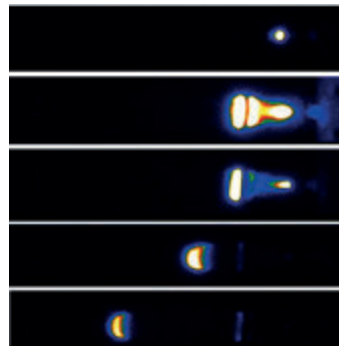

Zyla-HF

For indirect X-ray imaging

- ✓ Hard X-ray imaging and spectroscopy
- ✓ High Harmonic Generation (HHG)
- ✓ X-ray plasma spectroscopy
- ✓ X-ray tomography
- ✓ Transmission Electron Microscopy (TEM)

X-ray absorption image of
a wasp taken with a 40 kV
X-ray source, courtesy of
Crytur.

[Read more](#)

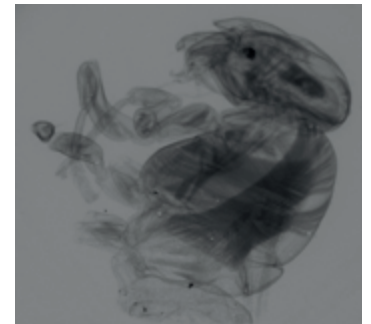

Balor sCMOS

Capture More. Further. Faster.

- ✓ Orbital debris & asteroid tracking
- ✓ Large sky surveys
- ✓ Solar studies
- ✓ Exoplanet discovery
- ✓ Supernovae detection

The highest resolution image
of the Sun's surface ever taken
using Balor sCMOS. Credit:
NSO/AURA/NSF

[Read more](#)

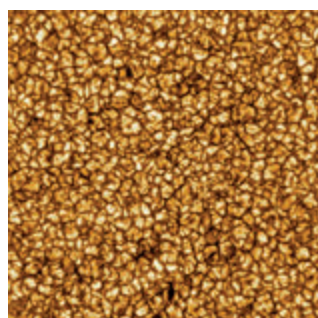

Balor-X or Marana-X sCMOS

Solution for High Energy Physics

- ✓ Hard X-ray & neutron tomography
- ✓ Hard X-ray microscopy
- ✓ X-ray diffraction & crystallography
- ✓ X-ray scattering - SAXS & WAXS
- ✓ Engineered material science

Have you found what you are looking for?

Need Larger Field of View? Balor sCMOS offers a 16.9 Megapixel sensor with 12 μm pixel pitch, reading the entire array in only 18.5 milliseconds.

Need faster frame rates? The Marana 4.2B-6 platform, configured with CoaXPress interface, can deliver 135 fps from a full 4.2 Megapixel array, faster still with sub-array selection.

Need more sensitivity? The Marana back-illuminated sCMOS family offers up to 95% QE for maximum photon capture. The iXon Ultra EMCCD platform offers single photon sensitivity and 95% back-illuminated QE, further boosted by cooling down to $-100\text{ }^{\circ}\text{C}$. Ideal for demanding light starved or single photon counting applications such as quantum entanglement studies.

Need better NIR performance? The iKon-M and iKon-L range of CCDs offer 'BEX2-DD' NIR-Enhanced options, extending sensitivity deep into the near-IR range. Ideal for exoplanet detection on dwarf stars as well as 785nm laser usages (e.g. BEC and near-IR Raman).

sCMOS for Spectroscopy and Andor Research-grade Spectrographs

Highly modular motorized platforms with dual output ports, dual/triple/quadruple grating turrets and a wide range of motorized and field-upgradable accessories.

Shamrock 750

Delivers the highest spectral resolution of the spectrograph range, down to 0.02 nm.

Shamrock 500i

Ideal combination of high spectral resolution, imaging capabilities for multi-track acquisitions. Convenient USB interface alongside fully motorized platform and light coupling accessories.

Shamrock 163

Rugged, compact 163 mm focal length manual spectrograph, highly configurable for general, everyday lab spectroscopy.

Kymera 193i

Intelligent, modular and compact imaging spectrograph with Adaptive Focus technology, fully motorized, RFID-tagged dual grating turret, dual detector output ports and seamless interfacing to microscopes for micro-spectroscopy applications.

Kymera 328i

Intelligent, modular and compact imaging spectrograph with Adaptive Focus technology and intelligent TruRes™ spectral resolution enhancement option. Quad grating turret and dual input and output ports allow ease of integration into demanding optical setups or multi-modal laboratories.



Technical Specifications

Model Specific Specifications^{*1}

Model	ZL41 Wave 5.5	ZL41 Wave 4.2		
Sensor type	Front Illuminated Scientific CMOS	Front Illuminated Scientific CMOS		
Active pixels (W x H)	2560 x 2160 (5.5 Megapixel)	2048 x 2048 (4.2 Megapixel)		
Sensor size	16.6 x 14.0 mm 21.8 mm diagonal	13.3 x 13.3 mm 18.8 mm diagonal		
Pixel readout rate (MHz)	200 (100 MHz x 2 sensor halves) 560 (280 MHz x 2 sensor halves)	216 (108 MHz x 2 sensor halves) 540 (270 MHz x 2 sensor halves)		
Read noise (e ⁻) Median [rms] ^{*2}	@ 200 MHz	Rolling Shutter 0.9 [1.2]	@ 216 MHz	Rolling Shutter 0.90 [1.1]
	@ 560 MHz	Global Shutter 2.3 [2.5] 1.2 [1.6]		@ 540 MHz
Maximum Quantum Efficiency ^{*3}	64%		82%	
Sensor Operating Temperature	0°C (up to 30°C ambient)		0°C (up to 27°C ambient)	
Air cooled	-10°C*		-10°C*	
Liquid/water cooled				
Dark current, e ⁻ /pixel/sec @ min temp ^{*4}	0.10		0.10	
Air cooled	0.019		0.019	
Liquid/water cooled				
Readout modes	Rolling Shutter and True Global Shutter (Snapshot)		Rolling Shutter and Global Clear ^{*7}	
Maximum dynamic range	33,000:1		33,000:1	
Photon Response Non-Uniformity (PRNU)				
Half-light range	< 0.01%			
Low light range	< 0.1%			
User defined ROI (granularity)	Yes (1 pixel) ^{**}			
Data range	12-bit (fastest USB 3.0 speeds) and 16-bit (maximum dynamic range)			
Interface options	USB 3.0 ^{*8} or Camera Link			

* Cooling temperature must be above the dew point

** Minimum ROI size: 4 x 8 (W x H) possible for 12- or 16-bit modes and for both Camera Link and USB 3.0 models

General Specifications^{*1}

Pixel size (W x H)	6.5 μm
Pixel well depth (e ⁻)	30,000
Linearity (% maximum) ^{*5}	
Full light range	Better than 99.8%
Low light range (< 1000 electrons signal)	Better than 99.9%
MTF (Nyquist @ 555 nm)	45%
Pixel binning	Hardware binning: 2 x 2, 3 x 3, 4 x 4, 8 x 8
Anti-blooming factor	x 10,000
I/O	External Trigger, Fire, Fire n, Fire All, Fire Any, Arm
Trigger Modes	Internal, External, External Start, External Exposure, Software Trigger
Software Exposure Events ^{*6}	Start exposure - End exposure (row 1), Start exposure - End exposure (row n)
Hardware timestamp accuracy	25 ns
Internal memory	1 GB



Imaging Mode

Frame Rate Table - 12-bit (16-bit)⁹

Array Size (W x H)	ZL41 Wave 5.5 USB 3.0		ZL41 Wave 5.5 10-tap		ZL41 Wave 4.2 10-tap	ZL41 Wave 4.2 USB 3.0
	Rolling Shutter	Global Shutter	Rolling Shutter	Global Shutter	Rolling Shutter	Rolling Shutter
2560 x 2160	40 (30)	40 (30)	100 (75)	49 (49)	-	-
2048 x 2048	53 (40)	52 (39)	105 (98)	52 (52)	101 (101)	53 (40)
1920 x 1080	107 (80)	98 (80)	200 (200)	97 (97)	192 (192)	107 (80)
512 x 512	422 (422)	201 (201)	422 (422)	201 (201)	406 (406)	406 (406)
128 x 128	1691 (1691)	716 (716)	1691 (1691)	716 (716)	1627 (1627)	1627 (1627)
2048 x 8 (FCS mode)	13020 (10250)	4008 (4008)	27057 (27057)	4008 (4008)	26041 (26041)	13020 (10250)
1024 x 8 (FCS mode)	27057 (27057)	4008 (4008)	27057 (27057)	4008 (4008)	26041 (26041)	26041 (26041)

Quantum Efficiency (QE) Curve ³

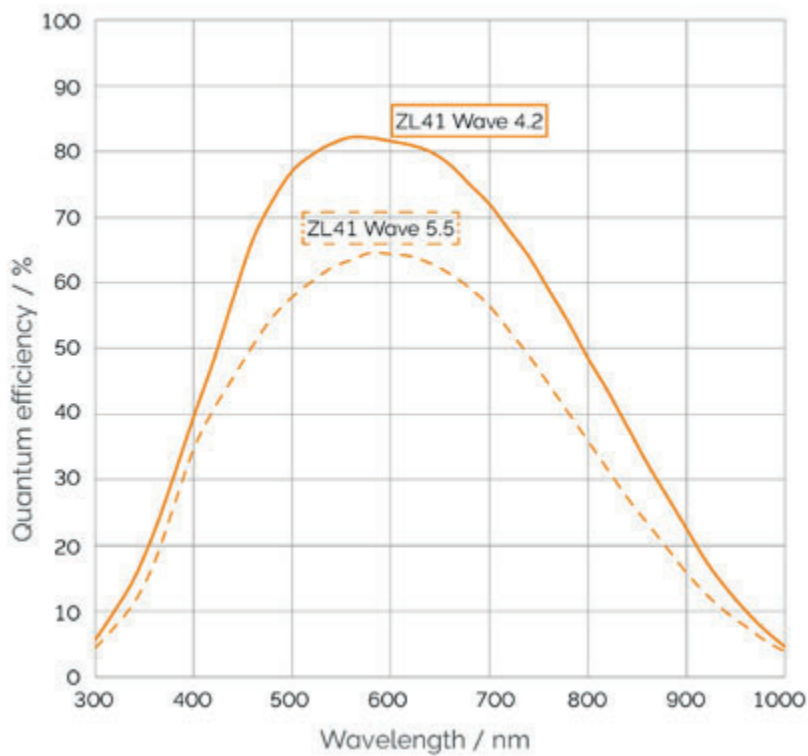

Creating The Optimum Product for You

Step 1. Select the camera type



Camera Type

Description	Code
ZL41 Wave 4.2, 4.2 Megapixel, Rolling shutter, 53 fps, USB 3.0	ZYLA-4.2P-USB3-S
ZL41 Wave 4.2, 4.2 Megapixel, Rolling shutter, 100 fps, Camera Link	ZYLA-4.2P-CL10-S
ZL41 Wave 5.5, 5.5 Megapixel, Rolling and Global shutter, 40 fps, USB 3.0	ZYLA-5.5-USB3-S
ZL41 Wave 5.5, 5.5 Megapixel, Rolling and Global shutter, 100 fps, Camera Link	ZYLA-5.5-CL10-S

For liquid cooled variant, insert '-W' in front of the '-S'. For example ZYLA-4.2P-USB-W-S
Please note this option provides liquid/water cooling *instead of* fan cooling, not both.

Step 2. Select the required accessories



Accessories

Description	Order Code
F-mount adapter	ACM-05574
Re-circulator for enhanced cooling performance	XW-RECR
Oasis 160 Ultra compact chiller unit	ACC-XW-CHIL-160
3 meter 7-way Multi I/O timing cable, offering Fire, External Trigger, Shutter and Arm.	ACC-ACZ-05612
5 meter cable for use with Axion frame grabber for Camera Link 10-tap models. (2 cables required)	ACC-ASE-13532
30 meter fibre-optic extender solution for Camera Link 10-tap models.	ACC-ZYLFOX-10TAP-30M
100 meter fibre-optic extender solution for Camera Link 10-tap models.	ACC-ZYLFOX-10TAP-100
15 meter active USB 3.0 connector cable (power supply not required). For use with ZL41 USB 3.0 models.	ACC-ASE-06887
50 meter fibre optic USB 3.0 extender solution including power supply. For use with ZL41 USB 3.0 models.	ACC-ASE-08762
100 meter fibre optic USB 3.0 extender solution including power supply. For use with ZL41 USB 3.0 models.	ACC-ASE-07860

Workstations are also available please enquire for more information. For further information on PC workstation requirements please refer to the technical note [PC Specifications for sCMOS Cameras](#)

Step 3. Select the required software



Software

ZL41 Wave also requires at least one of the following software options:

Solis Imaging A 32-bit and fully 64-bit enabled application for Windows (8.1 and 10) offering rich functionality for data acquisition and processing. AndorBasic provides macro language control of data acquisition, processing, display and export.

Andor SDK3 A software development kit that allows you to control the Andor range of cameras from your own application. Available as 32/64-bit libraries for Windows (8.1 and 10) and Linux. Compatible with C/C++, C#, Delphi, VB.NET, LabVIEW, MATLAB and Python.

Third Party Software Drivers are available so that the ZL41 Wave can be operated through a wide range of third party imaging packages. ZL41 Wave maintains compatibility with the previous Zyla family. [See our third party software matrix for more information.](#)

Product Drawings

Dimensions in mm (inches)

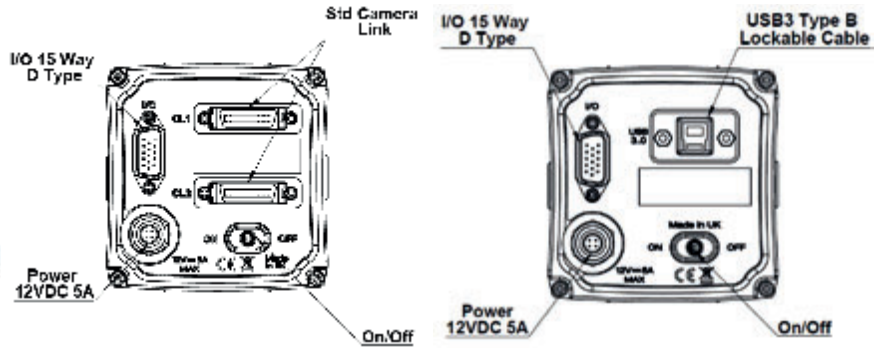
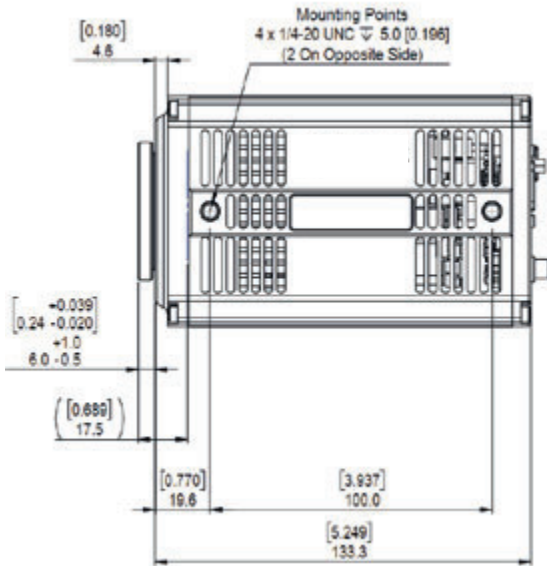
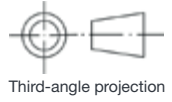

Weight: 1 kg [2 lbs 3 oz]

Product drawings of the water cooled ZL41 Wave can be found [here](#).

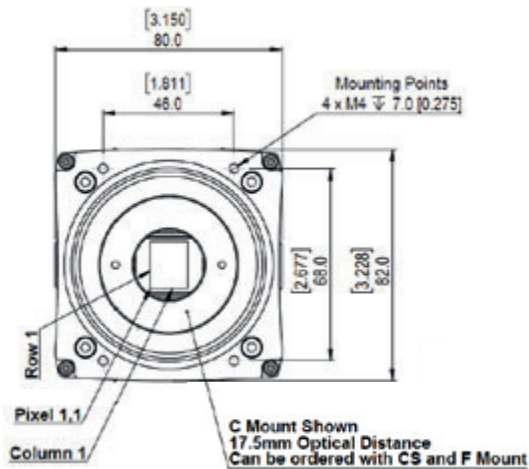

Regulatory Compliance

- RoHS compliant
- EU EMC Directive
- EU LV Directive
- IEC 61010-1 CB Scheme

External Power Supply Compliance

- UL-certified for Canada and US
- Japanese PSE Mark

Connecting to the ZL41 Wave

Camera Control

Connector type: 3 meter Camera Link connectors or USB 3.0.
(Longer lengths available as accessories).

TTL / Logic

1 x 3-way Multi I/O timing cable, offering Fire, External Trigger and Arm (1.5 meter)

Order Today

Need more information? At Andor we are committed to finding the correct solution for you. With a dedicated team of technical advisors, we are able to offer you one-to-one guidance and technical support on all Andor products.

andor.oxinst.com/contact

Your regional sales partner:



Quantum Design
EUROPE

Quantum Design GmbH
Breitwieserweg 9, D-64319 Pfungstadt
+49 6157 80710-0
germany@qd-europe.com
www.qd-europe.com



Items shipped with your camera

For Camera Link Models: 1 x Camera Link Card and 2 x 3 meter connector cables.
For USB 3.0 models: 1 x USB 3.0 PCIe Card and 1 x 3 meter USB 3.0 cable (Type A to B)
1 x Power supply with mains cable)
1 x 3-way Multi I/O timing cable, offering Fire, External Trigger and Arm (1.5 meter)
1 x Quick Start Guide
1 x User guide in electronic format
1 x Individual system performance sheet

Minimum Computer Requirements:

2.68 GHz Quad Core
4GB RAM (increase RAM if to be used for continuous data spooling)
Hard Drive:
Minimum 450 MB/s continuous write for USB 3.0 models
Minimum 850 MB/s continuous write for Camera Link
PCI Express x4 or greater for USB 3.0 models
PCI Express x8 or greater for Camera Link
Windows (8.1 or 10) or Linux

Operating and Storage Conditions

- Operating Temperature:
 - ZL41 Wave 5.5: -20°C to 30°C ambient
 - ZL41 Wave 4.2: -20°C to 27°C ambient
- Relative Humidity: < 70% (non-condensing)
- Storage Temperature: -20°C to 50°C

Footnotes: Specifications are subject to change without notice

1. Figures are typical unless otherwise stated.
2. Readout noise is for the entire system and is taken as a median over the sensor area excluding any regions of blemishes. It is a combination of sensor readout noise and A/D noise.
3. Quantum efficiency of the sensor at 20°C as supplied by the manufacturer.
4. Dark current measurement is taken as a median over the sensor area excluding any regions of blemishes.
5. Linearity is measured from a plot of Signal vs. Exposure Time, in accord with EMVA 1288 standard.
6. Software Exposure Events provide rapid software notification (SDK only) of the start and end of acquisition, useful for tight synchronization to moving peripheral devices e.g. Z-stage.
7. 'Global Clear' is an optional keep clean mechanism that can be implemented in rolling shutter mode, which purges charge from all rows of the sensor simultaneously, at the exposure start. The exposure end is still rolling shutter. It can be used alongside the Fire All output of the camera and a pulsed light source to simulate Global Exposure mechanism, albeit less efficiently than the true Global Shutter exposure mode of ZL41 Wave 5.5. Furthermore, Global Clear differs from true Global Shutter in that it can only be used in 'non-overlap' readout mode, i.e. sequential exposure and readout phases rather than simultaneous.
8. ZL41 Wave USB 3.0 models should work with any modern USB 3.0 enabled PC/laptop (provided hard drives or RAM is sufficient to support data rates) as every USB 3.0 port should have its own host controller. ZL41 Wave USB 3.0 models also ship with a USB 3.0 PCI card as a means to add a USB 3.0 port to an older PC, or as a diagnostic aid to interoperability issues or to ensure maximum speed.
9. The maximum frames/s table for ZL41 Wave indicate the maximum speed at which the device can acquire images in a standard system at full frame and also a range of sub-array size, for both rolling and global shutter read modes, 12-bit single amplifier. Sustained frame rates are dependent on write speed of the hard disc and other overheads of the acquisition software and hardware devices.

Power Requirements

- Power: +12 VDC ± 5% @ 5A
- Ripple: 200 mV peak-peak 0 - 20 MHz
- 100 - 240 VAC 50/60 Hz external power supply
- Power Consumption: 12 V @ 5 A Max, 12 V @ 2.5 A Nominal

