

Andor iDus CCD Series

Workhorse laboratory and OEM CCD platform

Fluorescence | Luminescence | Photoluminescence
Raman | Micro-spectroscopy | Non-linear spectroscopy

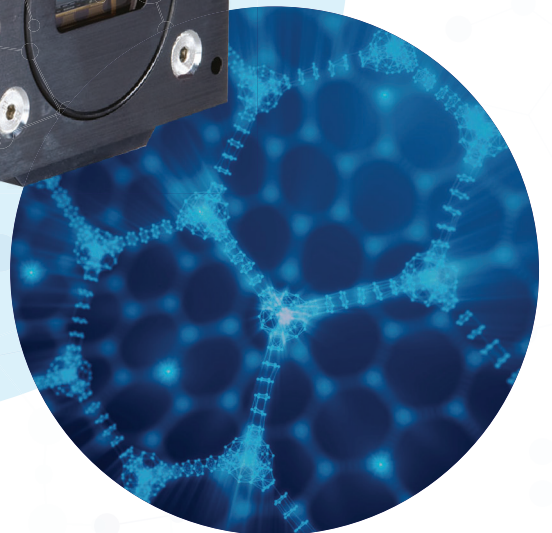
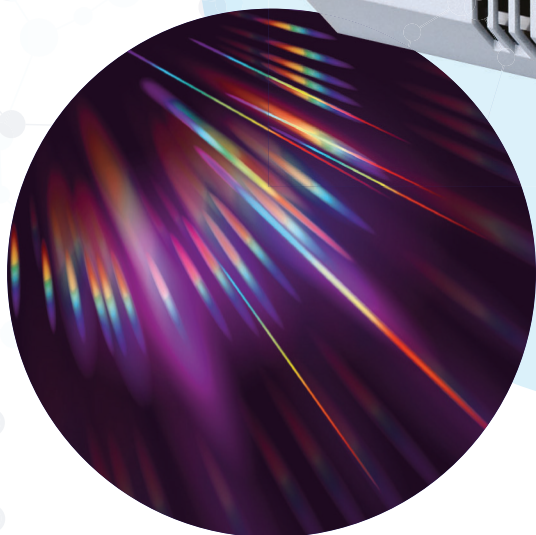
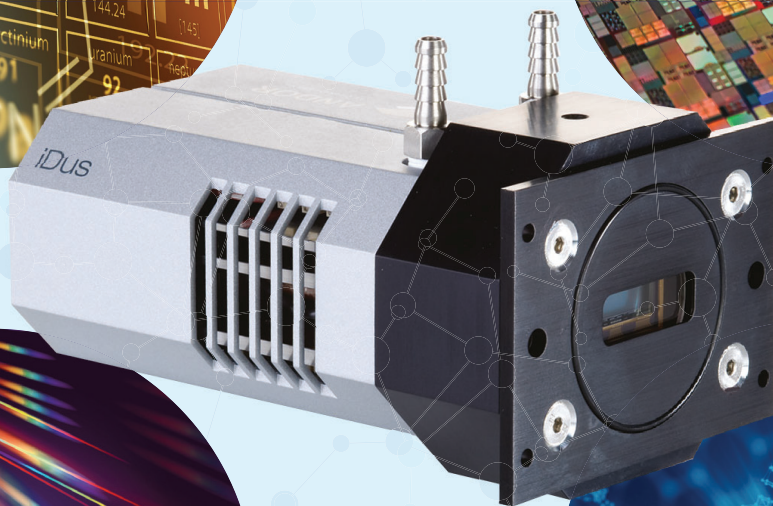
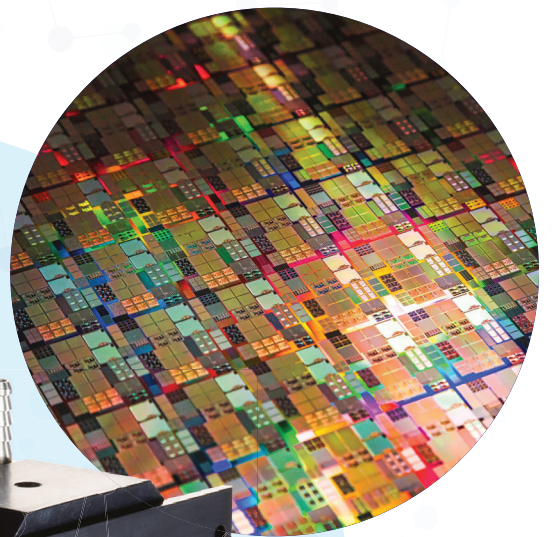

Introducing the iDus CCD series

The iDus CCD series offers compact, yet feature-rich platform suitable for demanding spectroscopy applications such as low-light UV/NIR Photoluminescence or Raman spectroscopy, as well as day-to-day routine laboratory operation and integration into industry-grade systems.

401

High dynamic range UV-NIR acquisitions, entry-level price-performance platform with 128 pixels height to accommodate optical setups based on single fibre or smaller spot size coupling to spectrographs.



416

Highest NIR sensitivity platform based on Low Dark Current Deep-Depletion technology, with 16 μm pixel and wider sensor to capture large spectral bandpass at high-resolution simultaneously.



420

High dynamic range UV-NIR acquisitions, 256 pixels height to accommodate optical setups based on extended multi-track fibre assemblies or larger spot size coupling to spectrographs.

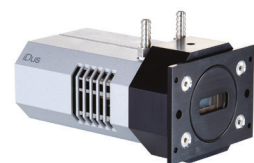

TE cooling removing inconvenient LN₂ cooling

Ultravac™ technology, longer-lasting detection performance

Low dark current deep-depletion technology option, highest NIR sensitivity

USB2.0 interface, plug-and-play convenience

Ideal for laboratory setups and OEM instruments integration

Andor iDus CCD series common features

Peak QE up to 95%	Best detection capabilities in the VIS and NIR spectral regions
TE cooling	Critical for elimination of dark current detection limit - no inconvenience associated with LN ₂ . Down to -100°C (401 and 420) and -95°C (416)
Ultravac™ e1	Critical for sustained vacuum integrity and to maintain unequalled cooling and QE performance, year after year
USB 2.0 connection	Ideal for laptop operation and seamless operation alongside USB-based Shamrock spectrograph family
Compact and rugged platform	Ideal for OEM integration & laboratory setups
Software-selectable pre-amplifier gain	Choice of best SNR performance or dynamic range at the touch of a button
Solis software for Spectroscopy	Comprehensive, user-friendly interface for simultaneous detector & spectrograph control
Software Development Kit (SDK)	Ease of control integration into complex setups: MATLAB, LabVIEW, Visual Basic or C/C++
Integrated in EPICS	Platform is fully integrated into the EPICS control software

401

Peak QE up to 95%	Visible-optimised 'BVF' & infrared-optimised 'BR-DD' model
Fringe suppression technology as standard	Effectively minimises signal modulation due to optical fringing in back-illuminated sensors
26 x 26 µm pixels	Optimised format for high dynamic range and resolution

416

Peak QE up to 95%	Best detection capability in the NIR
Low dark current	10x better than back-illuminated deep-depletion NIMO sensors, best SNR in the NIR
15 µm pixels	Ideal for high resolution spectroscopy
Fringe suppression technology as standard	Effectively minimises signal modulation due to optical fringing in back-illuminated sensors
30 mm wide sensor	Superior simultaneous band-pass capture

420

Peak QE up to 95%	Visible-optimised 'BV', broadband UV-NIR 'BEX2-DD' model
26 x 26 µm pixels	Optimised pixel format for high dynamic range and resolution
Fringe suppression technology	Effectively minimises signal modulation due to optical fringing in back-illuminated sensors (BVF, BEX2-DD models). Open-Electrode (OE) option is not subjected to optical fringing.

Specifications^{o2}

	DU401A		DU401A BR-DD		
Sensor options	BVF: Back Illuminated CCD, Vis-optimised and anti-fringing		BR-DD: Back Illuminated CCD, Deep Depletion with anti-fringing, optimum sensor for Near IR applications		
Active pixels	1024 x 127				
Pixel size	26 x 26 µm				
Image area	26.6 x 3.3 mm with 100% fill factor				
Minimum temperatures*4 Air cooled Coolant recirculator Coolant chiller, coolant @ 10°C, 0.75l/ min	-80°C -95°C -100°C				
Max spectra per second	88 (10 row crop mode), 81 (Full Vertical Bin)				
System window type	BVF sensor: UV-grade fused silica, 'Broadband VUV-NIR', unwedged		BR-DD sensor: UV-grade fused silica, 'VIS-NIR enhanced', wedged (Various AR coatings & MgF ₂ options available)		
Blemish specifications	Grade 1 sensor from supplier. Camera blemishes as defined by Andor Grade A See technical article: CCD blemishes and non uniformities black pixels and hot pixels on a ccd sensor				
Dark current, e-/pixel/sec @ max cooling	BVF 0.003		BR-DD 0.013		
Register well depth	1,000,000 e ⁻				
Read noise (e-)*6 Typ (Max)	BVF		BR-DD		
	33 kHz	7 (8)	5 (6)		
	50 kHz	10 (12)	6 (8)		
100 kHz	12 (15)	10 (15)			
Sensitivity (e-/count)	BVF		BR-DD		
		High Dynamic Range	High Sensitivity	High Dynamic Range	High Sensitivity
	33 kHz	2.5	-	2.5	-
	50 kHz	3.5	2.5	4.5	2.7
100 kHz	16	11	18.2	12	
Vertical clock speed*8	8, 16, 32, 64 µs (software selectable)				

DU416A-LDC-DD	DU420A	DU420A BEX2-DD
LDC-DD: Back-Illuminated CCD, Deep-Depletion with anti-fringing, low dark current	BU: Back Illuminated CCD, UV-Enhanced, 350 nm optimised BU2: Back Illuminated CCD, UV-Enhanced, 250 nm optimised BVF: Back Illuminated CCD, VIS optimised with anti-fringing OE: Open Electrode CCD	BEX2-DD: Back Illuminated, Deep Depletion CCD with anti-fringing, extended range dual AR coating
2000 x 256	1024 x 256	1024 x 255
15 x 15 µm	26 x 26 µm	
30 x 3.8 mm with 100% fill factor	26.6 x 6.6 mm with 100% fill factor	
-80°C -90°C -95°C	-80°C -95°C -100°C	
30 (Full Vertical Binning)	88 (10 rows crop mode), 75 (Full Vertical Bin), 65 (Open Electrode, Full Vertical Bin)	
Fused silica window, 'VIS-NIR Enhanced', wedged (AR coated on both sides, optimised at 900 nm) Other broadband UV-NIR options available on request.	BU, BU2, BVF, OE sensors: UV-grade fused silica, 'Broadband VUV-NIR', unwedged	BEX2-DD sensor: UV-grade fused silica, 'Broadband VUV-NIR', wedged (Various AR coatings & MgF ₂ options available)

LDC-DD	OE	BU / BU2 / BVF	BEX2-DD
0.0006	0.002	0.002	0.008
300,000 e ⁻	1,000,000 e ⁻		
LDC-DD	OE	BU, BU2, BVF	BEX2-DD
4	4 (6)	6 (8)	4 (6)
4.5	4 (6)	7 (9)	5 (7)
5	9 (11)	10 (12)	10 (13)
LDC-DD	OE	BU, BU2, BVF	BEX2-DD
High Dynamic Range	High Dynamic Range	High Dynamic Range	High Dynamic Range
High Sensitivity	High Sensitivity	High Sensitivity	High Sensitivity
0.7	2.5	2.5	2.5
-	-	-	-
1.5	3.5	3.5	4.0
0.85	2.5	2.5	2.5
5.0	15	15	17
3.4	9	9	11
32 and 64 µs (software selectable)	8, 16, 32, 64 µs (software selectable)		

Dark Current⁹

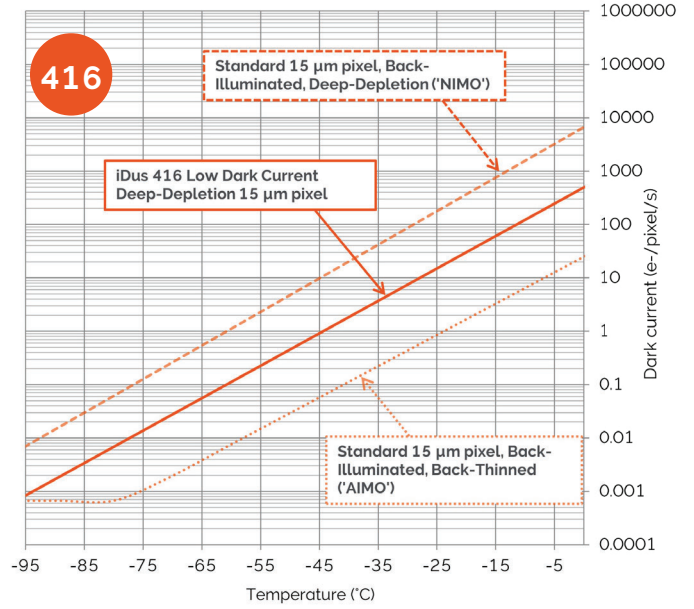
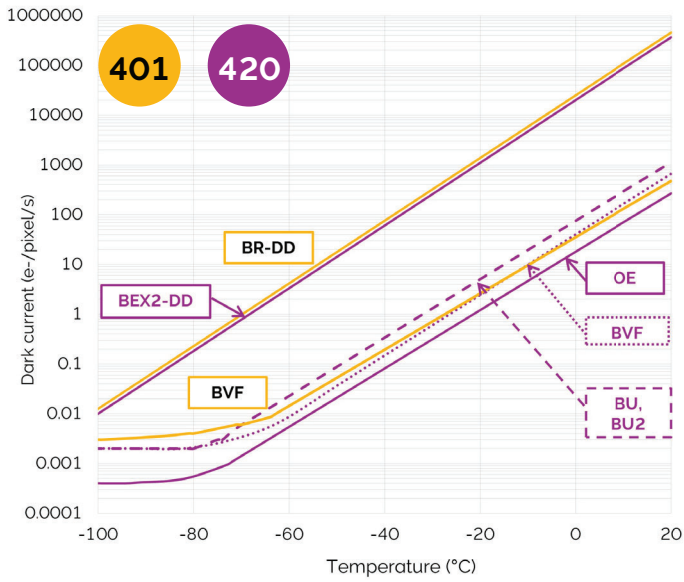

Quantum Efficiency Curves¹⁰

25°C

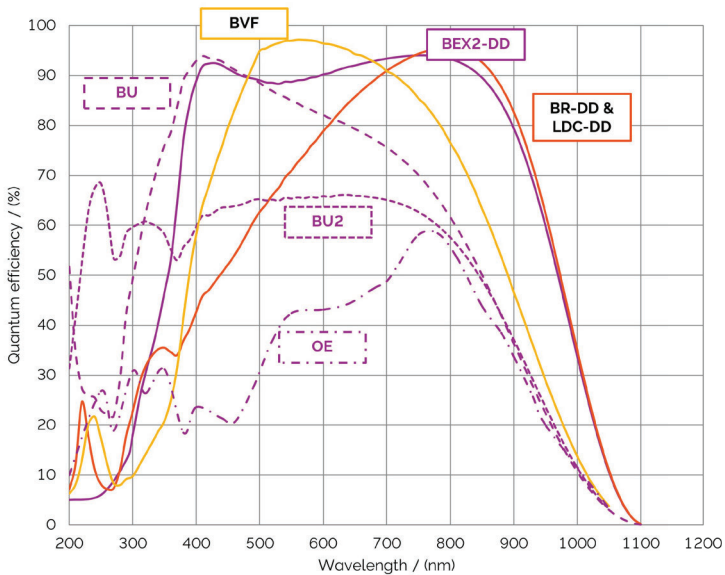

-95°C

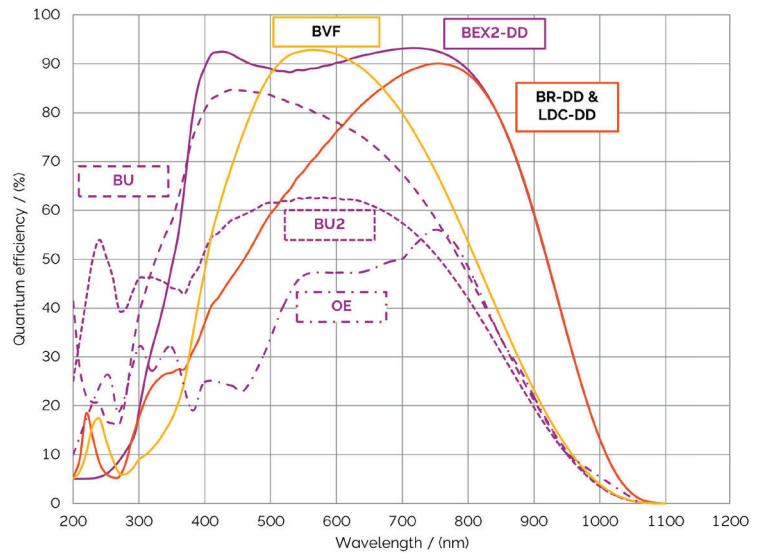

iDus applications guide

Applications guide	BR-DD	LDC-DD	BU / BU2	BVF	BEX2-DD	OE
Absorption/transmittance/reflection	○	○	○	●	○	○
Fluorescence & luminescence	○	○	○	●	○	○
NIR spectroscopy	○	●			○	○
Raman spectroscopy (244 – 488 nm)			●	○		○
Raman spectroscopy (514, 531, 633 nm)			○	●	○	○
Raman spectroscopy (785, 830 nm)	○	●			○	○
UV-VIS-NIR broadband spectroscopy					●	○

● - Optimum ○ - Suitable

Our cameras for spectroscopy

See our full range for alternative cameras that could fit your application requirements.



High sensitivity & dynamic range

- Long exposure
- High sensitivity UV-SWIR
- Large pixel well depths

iDus CCD & InGaAs,
Newton CCD & EM

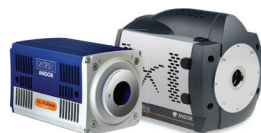

kHz spectral rates

- μ s to ms time-resolution
- High sensitivity down to single photon
- High resolution matrix

Newton CCD & EMCCD,
iXon EMCCD,
ZL41 Wave or
Marana sCMOS



ns to μ s time-resolution

- Nanosecond gating
- High sensitivity down to single photon
- On-head DDG with ps accuracy

iStar CCD & sCMOS

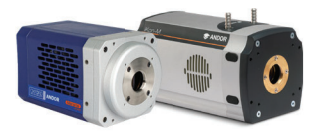

Extended multi-fibre spectroscopy

- Large area sensors
- Ultrafast sCMOS and EMCCD options
- High sensitivity down to single photon

iKon-M CCD,
iXon EMCCD, ZL41 Wave,
Marana sCMOS or
iStar CCD & sCMOS

Learn more about our detector range [here](#) and our spectrograph solutions [here](#).



Product drawings 401 and 420 models

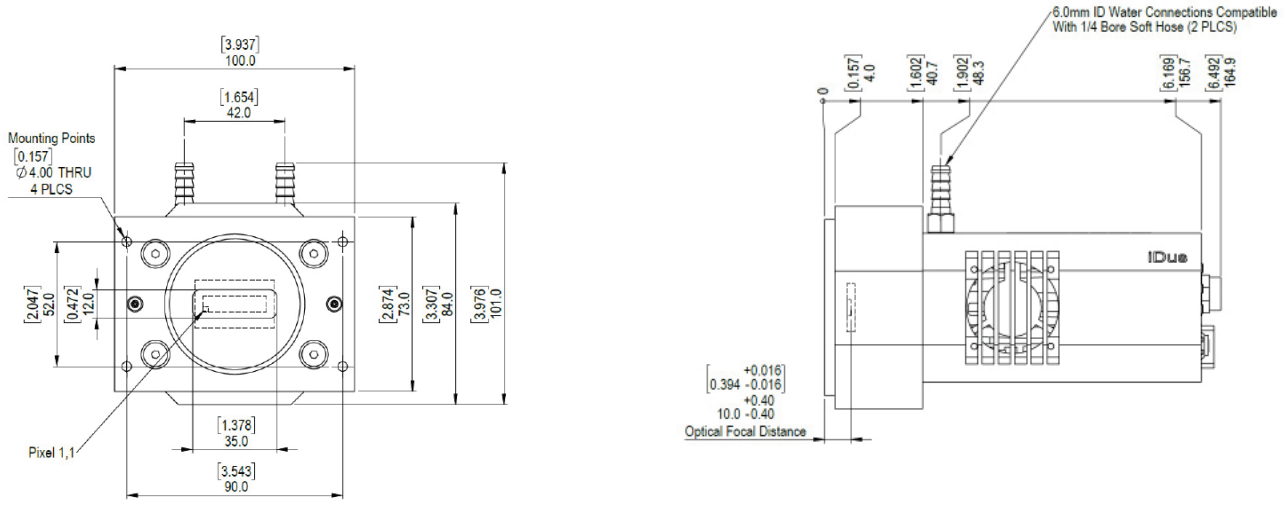

Mounting hole locations

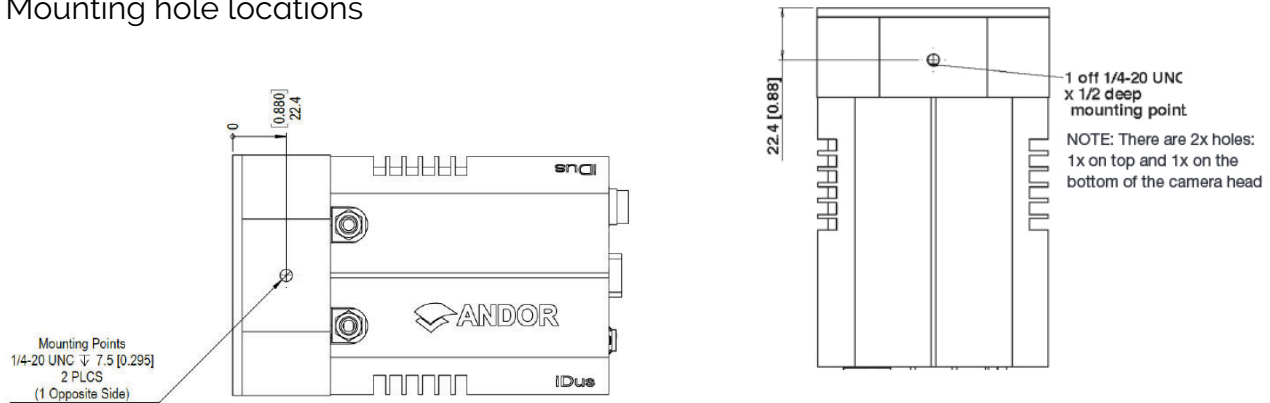

Rear connector panel

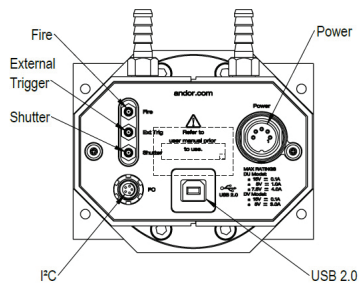

Product drawings 416 model

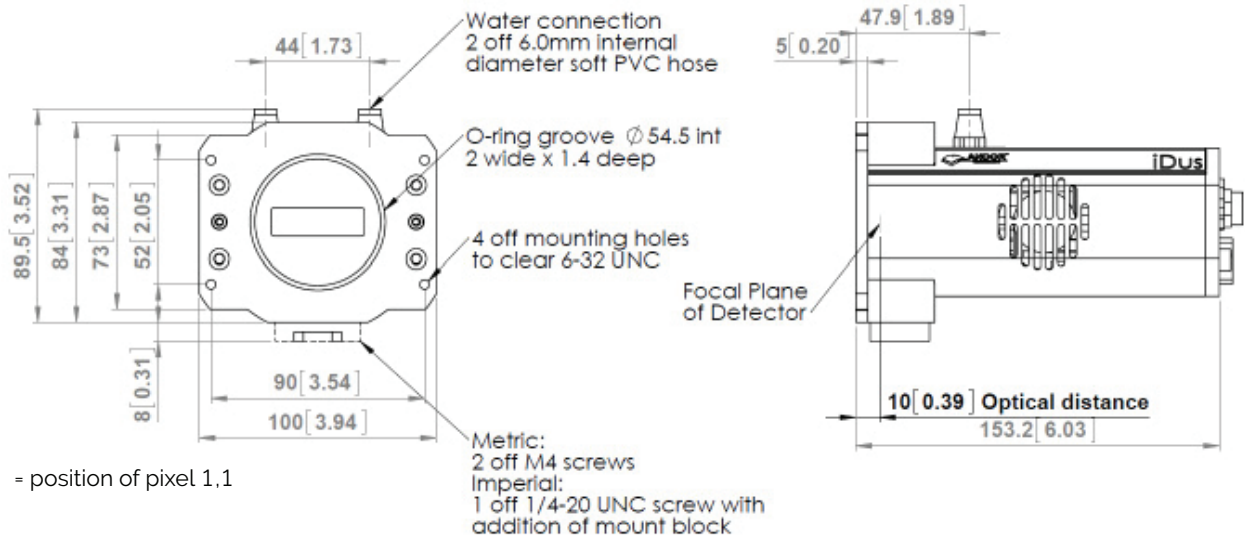

Mounting hole locations

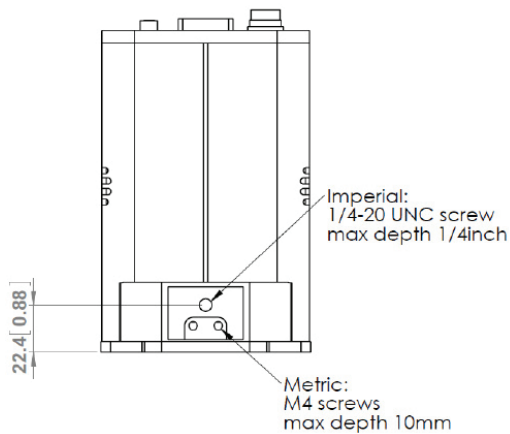

Rear connector panel

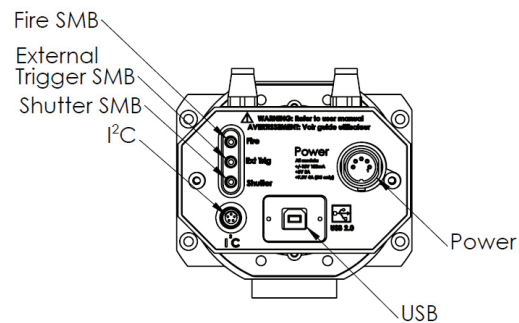
**Items shipped with your camera:**

- 1x 2 m BNC - SMB connection cable
- 1x 3 m USB 2.0 cable Type A to Type B
- 1x Set of hex keys (7/64" & 3/32")
- 1x Power supply with mains cable
- 1x Electronic copy of user guides
- 1x Individual system performance booklet
- 1x Electronic copy of Solis software or SDK (if ordered)

Recommended computer requirements:

- 3.0 GHz single core or 2.4 GHz multi core processor
- 2 GB RAM
- 100 MB free hard disc to install software (at least 1 GB recommended for data spooling)
- USB 2.0 High Speed Host Controller capable of sustained rate of 40 MB/s
- Windows (8.1, 10 and 11) or Linux

Operating and storage conditions

- Operating Temperature: 0°C to 30°C ambient
- Relative Humidity: < 70% (non-condensing)
- Storage Temperature: -25°C to 50°C

Power requirements

- 100 - 240 VAC, 50 - 60 Hz
- Power consumption: 42 W (max)

Regulatory Compliance

Compliant with the requirements of the EU EMC and LVD Directives, compliant with the international EMC and safety standards IEC 61326-1 and IEC 61010-1.

Creating the optimum product for you

Step 1. Select the camera type



Camera type

401

Description all models with deep cooling: (air cooled: -80°C, coolant recirculator: -95°C, coolant chiller, coolant @ 10°C, 0.75 l/min: : -100°C)	Order code
Back-illuminated CCD, Vis-optimised with anti-fringing.	DU401A-BVF
Back-illuminated CCD, Deep Depletion CCD with anti-fringing.	DU401A-BR-DD

416

Description	Order code
Back-illuminated Deep Depletion CCD with fringe suppression, Low Dark Current, Deep Depletion technology(LDC-DD). Deep cooling: (Air cooled: -80°C, Coolant recirculator: -90°C, Coolant chiller, coolant @ 10°C, 0.75 l/min: : -95°C)	DU416A-LDC-DD

420

Description all models with deep cooling: (air cooled: -80°C, coolant recirculator: -80°C, coolant chiller, coolant @ 10°C, 0.75 l/min: : -100°C)	Order code
Back-illuminated, Deep Depletion CCD with fringe suppression and extended range dual AR coating.	DU420A-BEX2-DD
Back-illuminated CCD, Blue optimised AR coating for spectroscopy.	DU420A-BU
Back-illuminated CCD, enhanced silicon, AR coated for optimised performance in the 250 nm region.	DU420A-BU2
Back-illuminated CCD, Vis-optimised & anti-fringing.	DU420A-BVF
Open electrode CCD.	DU420A-OE

Step 2. Select an alternative camera window



Camera window

The standard window has been selected to satisfy most applications. However, other options are available and the alternative camera window code must be specified at time of ordering.

To view and select other window options please refer to the [Camera Windows Selector Tool](#). Further detailed information on windows can be found in the technical note – [How to Select a Window for your Camera](#).

Step 3. Select the required accessories

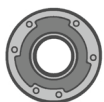

Accessories

Accessories description	Order code
Coolant re-circulator for enhanced cooling performance	XW-RECR
Oasis 160 Ultra Compact Chiller Unit (tubing to be ordered separately)	ACC-XW-CHIL-160
6 mm tubing options for ACC-XW-CHIL-160 (2x2.5 m or 2x5 m lengths)	ACC-6MM-TUBING-2X2.5 / ACC-6MM-TUBING-2X5M
C-mount lens adaptor	ACC-LM-C
F-mount lens adaptor	ACC-LM-NIKON-F
Nikon F-mount lens adaptor with shutter	LMS-NIKON-F-NS25B
Shutter Driver for NS25B Bistable Shutter (not needed for Kymera/Shamrock spectrographs)	ACC-SD-VED24
Bistable Shutter, Standalone (not needed for Kymera/Shamrock spectrographs)	ACC-SHT-NS25B

Spectrograph Compatibility

The iDus series is fully compatible with Andor's Kymera and Shamrock spectrographs (193 - 750 mm focal lengths). Spectrograph mounting flanges and software control are available for a wide variety of third party spectrographs including McPherson (including 1 m and greater focal length option), JY/Horiba (excluding USB models), PI/Acton, Chromex/Bruker, Oriel/Newport, Photon Design, Dongwoo, Bentham, Solar TII and others.

Step 4. Software



Software

The iDus requires at least one of the following software options:

Solis for Spectroscopy A 32-bit and fully 64-bit enabled application for Windows (10 and 11) offering rich functionality for data acquisition and processing. AndorBasic provides macro language control of data acquisition, processing, display and export. Control of Andor Kymera and Shamrock spectrographs and a very wide range of third party spectrographs is also available, see list in step 3 above.

Andor SDK A software development kit that allows you to control the Andor range of cameras from your own application. Available as 32/ 64-bit libraries for Windows (10 and 11) and Linux. Compatible with C/C++, C#, Delphi, VB.NET, LabVIEW, MATLAB and Python.

Footnotes

- Assembled in a state-of-the-art facility, Andor's UltraVac™ vacuum process combines a permanent hermetic vacuum seal (no o-rings), with a stringent protocol and proprietary materials to minimise outgassing. Outgassing is the release of trapped gases that would otherwise degrade cooling performance and potentially cause sensor failure.
- Figures are typical unless otherwise stated.
- Edge pixels may exhibit a partial response.
- Minimum temperatures listed are typical values with ambient temperature of 25°C.
- Based on a Horizontal Pixel Readout of 100 kHz and a vertical pixel shift of 8 μs. Due to the nature of the Open Electrode sensor, the minimum Vertical Shift Speed (VSS) available is 32 μs, which will produce a lower maximum spectral rate compared to other models in the series.
- Readout Noise is for the entire system. It is a combination of CCD readout noise and A/D noise. Measurement is for Single Pixel readout with the CCD at a temperature of -50°C (BEX2-DD models tested at -80°C) and minimum exposure time under dark conditions. Noise is measured at the highest available pre-amplifier gain for each speed.
- Linearity is measured from a plot of counts vs exposure time under constant photon flux up to the saturation point of the system.
- Vertical speeds are software selectable. All sensors are designed to give optimum Charge Transfer Efficiency (CTE) at 16 μs vertical pixel shift (32 μs for Open Electrode model), some decrease in CTE may be observed at faster shift speeds.
- The graph shows typical dark current level as a function of temperature. The dark current measurement is averaged over the CCD area excluding any regions of blemishes.
- Quantum efficiency of the sensor as supplied by the sensor manufacturer.

Order Today

Need more information? At Oxford Instruments we are committed to finding the correct solution for you. With a dedicated team of technical advisors, we are able to offer you one-to-one guidance and technical support on all products.

For a full listing of our local sales offices, please see: andor.oxinst.com/contact

Your regional sales partner:



Quantum Design GmbH
Breitwieserweg 9,
D-64319 Pfungstadt
+49 6157 80710-0
germany@qd-europe.com
www.qd-europe.com

Note

Oxford Instruments reserves the right to alter without notice the specification, design or conditions of supply of any product or service.

Original document in English.