



DATASHEET

01.2019

LedMOD[®]

TEC-cooled High Power LED modules with optional fibre-coupling



The LEDMOD V2 modules offer great functionality and flexibility for applications in industry and research. With more than 40 different wavelengths from deep UV to the near infrared and optical output power of several hundred milliwatts, the so-called "LEDMOD" series can be used in many applications such as microscopy, chemical analysis, spectroscopy, forensics and other areas. The LED modules are available in a fibre-coupled version or with free emission. The modules have modulation inputs for fast analogue intensity modulation with up to 200 kilohertz and digital modulation with a switching time of $2\mu s$. High-precision temperature stabilization of the LED chips ensures a very good performance and wavelength stability. This is important especially for applications that not only need an exact output power, but also a high stability of the emission spectrum. The digital modulation can be operated via external modulation signals, as well as an internal, programmable signal generator. A SYNC output ensures synchronization with external devices such as cameras, spectrometers and lock-in amplifiers. One or several optional "LEDMOD" modules can be comfortably controlled via RS-232 and USB 2.0 interface by either the supplied software 'Omicron Control Center' or the customer's own software.

Dimensions:

Control Software:

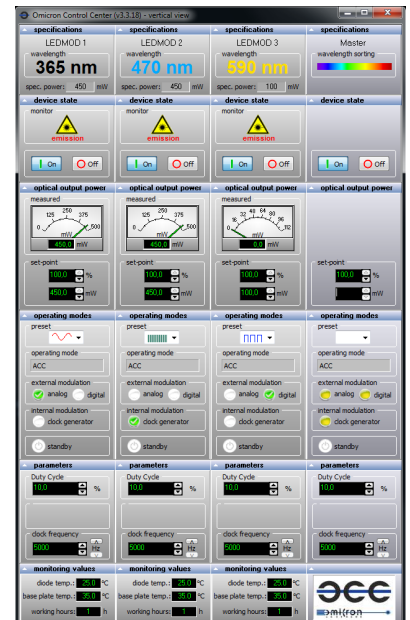
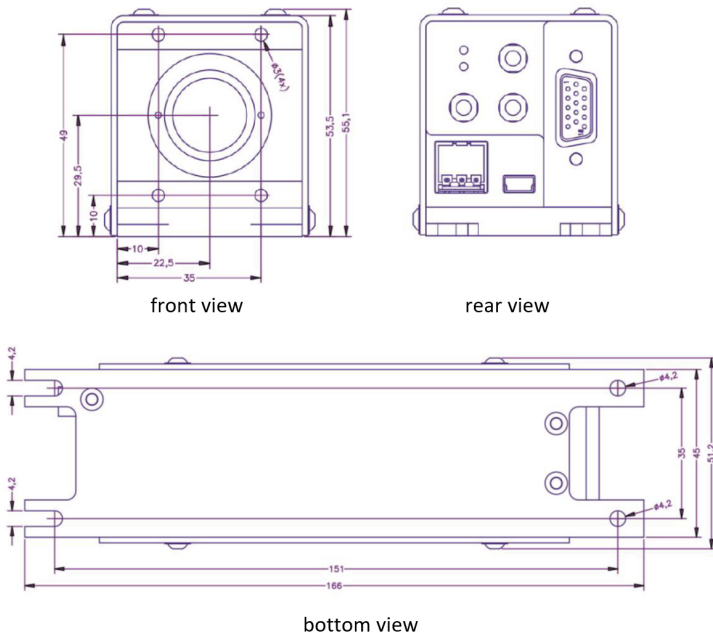

Omicron-Laserage Laserprodukte GmbH
 Phone: +49 (0) 6106 8224-0
 Raiffeisenstraße 5e
 63110 Rodgau – Germany

Fax: +49 (0) 6106 8224-10
www.omicron-laser.de
mail@omicron-laser.de

For more online information:



LEDMOD Series - Specifications

LEDMOD V2	
Wavelengths & Powers (other wavelengths and powers on request)	Deep-UV: 255nm / 150µW * 265nm / 400µW * 275nm / 6mW * 280nm / 600µW * 310nm / 6mW * 340nm / 50mW UV / Violett: 365nm / 450mW 385nm / 450mW 405nm / 450mW VIS: 455nm / 450mW 470nm / 450mW 505nm / 100mW 528nm / 100mW 590nm / 100mW 617nm / 450mW 625nm / 450mW IR: 850nm / 800mW 950nm / 800mW White: 5600K / 400mW
Free emission angle	120 - 130° (Deep-UV 10°)
Temperature control	active peltier cooling (TEC)
External modulation capabilities	up to 500kHz analogue modulation up to 500kHz digital modulation
Modulation inputs	1x Analogue modulation (0...5V / 2.5kOhm) via SMA Connector 1x Digital modulation (TTL / 5kOhm) via SMA Connector
Internal modulation capabilities	Up to 200kHz with programmable frequency and duty-cycle
Power setting resolution	internal: 12Bit external: analogue
SYNC output	TTL signal via SMA connector
Computer interface	USB-2.0 and RS-232
Operation modes	1.) external analogue control (0...5V) for output power and additional external TTL signal for ON/OFF modulation 2.) internal power control with external TTL for ON/OFF modulation 3.) internal power control CW (continues wave) operation (no external signals necessary) 4.) internal power control + programmable frequency and duty-cycle for ON/OFF modulation (no external signals necessary) 5.) external power control (0...5V) for output power + programmable frequency and duty-cycle for ON/OFF modulation
Control interface	15-pin HD-Sub-D connector
Dimensions (without fibre-coupling unit)	56x52x166mm (HxWxL).
Weight	350g
Supply voltage	11VDC-25VDC
Power consumption	27W max. <1W in standby
Environmental temperature	0°C-45°C
Certifications	CE, UL/CSA on request
Special features	* Interlock function * Over-TEMP protection * Remote-control * SYNC output
Options	* High-efficiency fibre coupling into high-NA POF and fused-silica fibres (e.g. 2mm / 70%, 1mm / 35%) * Collimating and focussing objectives * Beam shaping (diffractive and refractive)

Laser Safety classification:

Klicken oder tippen Sie hier Text einzugeben.

300-400nm:



390-410nm:



400-700nm:



700-2000nm:



Control Interface

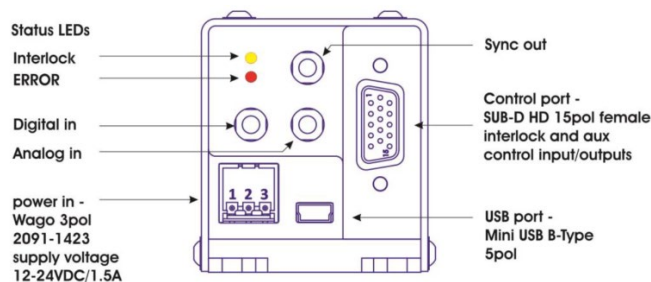

Ordering Code

