

VUV-VASE[®]



J.A. Woollam Co., Inc.

Ellipsometry SolutionsSM

FIRST IN THE VUV

The VUV-VASE® variable angle spectroscopic ellipsometer is the gold standard for optical characterization of lithography thin films. It measures wavelengths from vacuum ultraviolet (VUV) to near infrared (NIR). This provides incredible versatility to characterize numerous materials: semiconductors, dielectrics, polymers, metals, multi-layers and liquids such as immersion fluids.

WHY A VUV-VASE?

WIDE SPECTRAL RANGE

The VUV-VASE covers wavelengths from below 140nm to 1700nm.

HIGH ACCURACY

Utilizing our patented AutoRetarder®, the VUV-VASE guarantees accuracy for any sample measurement.

CONVENIENT SAMPLE LOADING

Special design allows fast, efficient sample loading without contaminating system purge.

PROTECT YOUR SAMPLES

The monochromator is placed before the sample to limit exposure of photosensitive materials.

VUV-VASE Gen-II



TWO GENERATIONS

The VUV-VASE[®] was developed in 1999 to meet metrology requirements for 157nm lithography research. The first generation (Gen-I) tool is perfect for new materials research. A second generation (Gen-II) tool was introduced to provide large area mapping of photomasks and wafers.



GEN-I

Measure samples up to 200mm diameter.



GEN-II

Translation Options:

- 140mm XY
- 300mm R-Theta

KEY FEATURES

WAVELENGTH RANGE

The VUV-VASE can measure any wavelengths between 140nm and 1700nm, or photon energies between 0.73eV and 9eV.

NITROGEN PURGE

The VUV-VASE is purged continuously with dry nitrogen gas to eliminate the atmospheric absorption of light below 190nm by oxygen and water vapor.

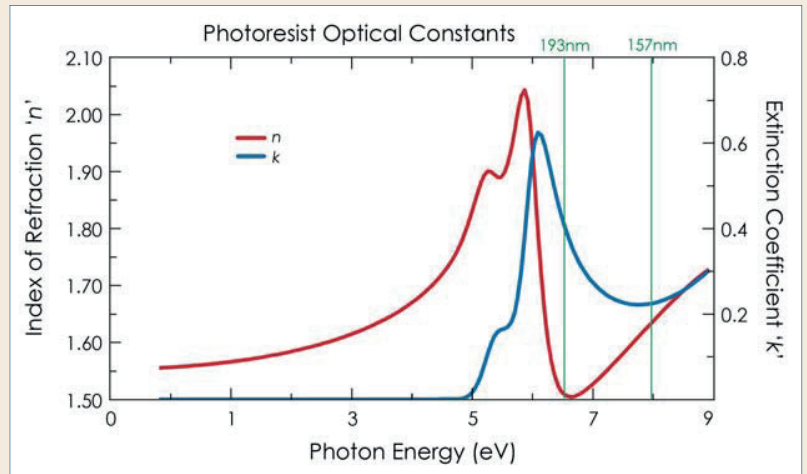

Gen-I Sample Load Lock



ANGLE RANGE

The VUV-VASE systems feature automated angle of incidence with wide angular coverage.

GEN-I 10°-90° (wavelengths <300nm)
25°-90° (wavelengths >300nm)

GEN-II 10°-90° (wavelengths <300nm)
20°-90° (wavelengths >300nm)

AUTOMATED SAMPLE ALIGNMENT

Load your samples and the stage automatically aligns to ensure proper sample placement (tip-tilt-z).

LOAD LOCK

Samples are conveniently loaded without reducing purge quality throughout the instrument via a load-lock surrounding the sample region.



Gen-II Sample Stage

CHARACTERIZATION

WIDE RANGE

The VUV-VASE[®] measures a very wide photon energy range from 0.73eV to 9eV. This allows study of the electronic transitions in all types of semiconducting and dielectric films. The high energy electronic transitions of group-III Nitrides affect the VUV dielectric functions, as shown to the right.

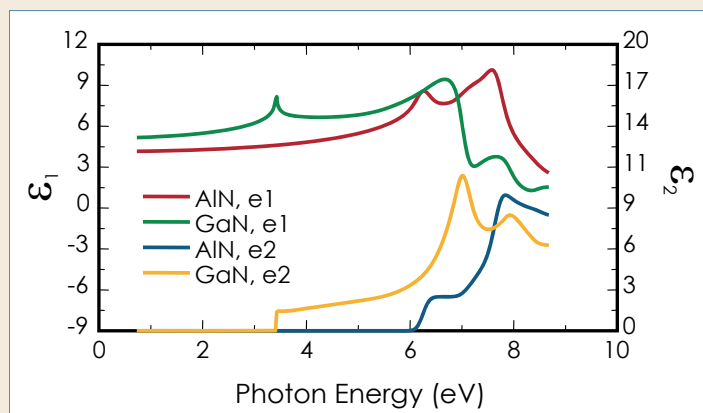

ULTRA-THIN FILMS

The VUV-VASE offers two advantages for ultra thin film characterization:

- Short wavelengths are more sensitive to thin layers.
- UV absorption differentiates materials.

Data (right) from a high-K gate dielectric thin film are modeled using SiO₂ optical constants and a transparent dispersion model. Neither match the data in the VUV. A Tauc-Lorentz oscillator model correctly describes the material optical constants and matches data over the full spectral range.

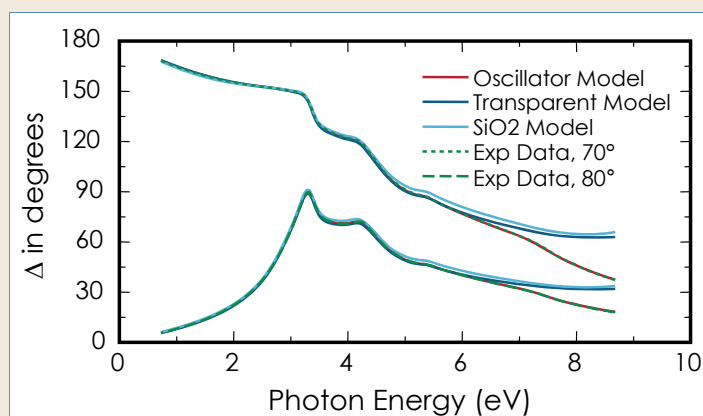

R/T DATA

The VUV-VASE can measure reflected or transmitted intensity from your samples. Measure R/T at different angles of incidence and your choice of polarizer direction.

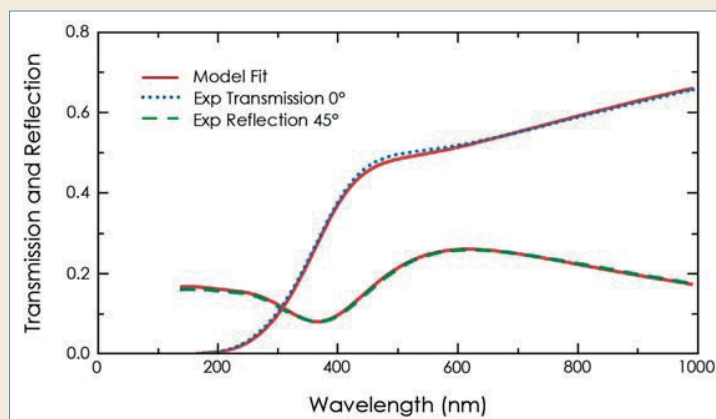

Polarized transmission and reflection for coated optic measured with VUV-VASE.

ADVANCED MEASUREMENTS

ANISOTROPY/MUELLER-MATRIX

Complex materials and nanostructures often require advanced characterization methods. The VUV-VASE can measure “generalized-SE” data from anisotropic materials and “Mueller-matrix” data from more complex structures.

Dielectric functions for hexagonal silicon carbide are anisotropic. In figures to the left, the ordinary and extraordinary properties are both measured. Notice the large differences in the VUV region.

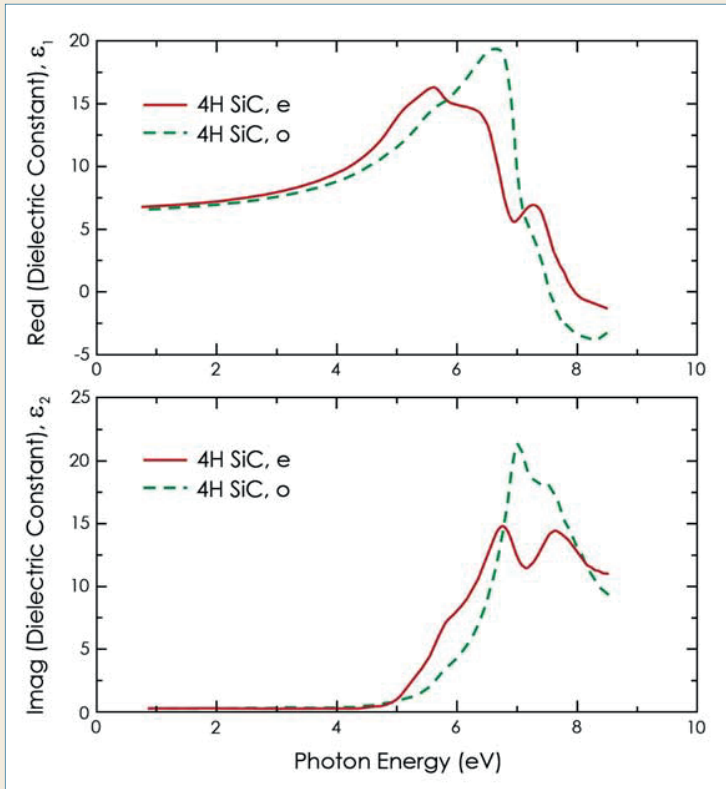

Gen-II Sample Loading



AUTORETARDER[®]

The VUV-VASE accuracy is ensured by our patented AutoRetarder*. The AutoRetarder is a computer controlled Berek waveplate that introduces controlled retardance into the measurement beam. In this manner, the polarization state probing the sample is manipulated to ensure the best results for any sample.

*U.S. Patent #5,757,494



LITHOGRAPHY APPLICATIONS

Lithography thin films were an important motivation for the VUV-VASE® development. It has been successfully used to characterize all types of films in this area, including:

- Photoresists
- Bottom and Top AR Coatings
- Photomask Coatings
- Hardmasks
- Stepper Optical Coatings
- Pellicles
- CaF₂ Optics
- And more...

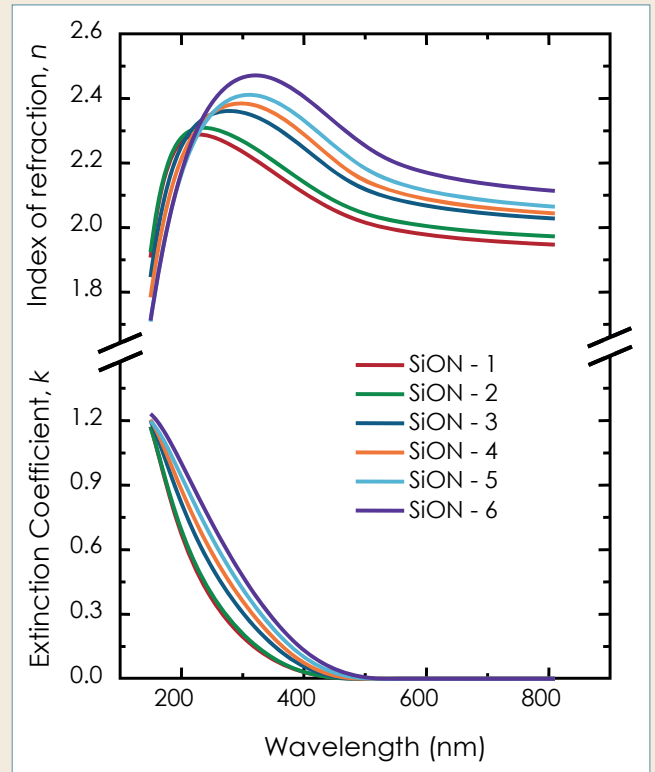

PHOTORESIST

Measure film thickness and refractive index (n and k) at all lithography lines: 157nm, 193nm, 248nm...

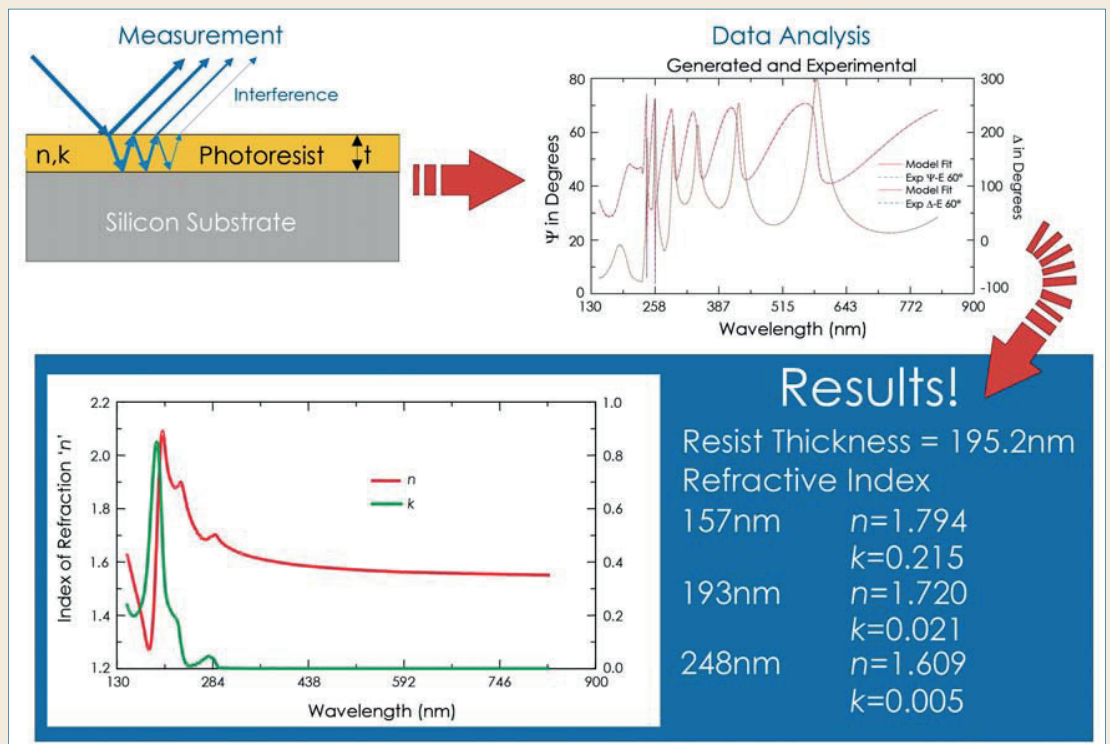

COATINGS ON STEPPER OPTICS

Optical elements used in lithography exposure tools can be enhanced using optical coatings. Coating merit depends on refractive index and thickness. Fluorinated materials are candidates at 157nm, as they remain transparent into the VUV. The index for various fluorides measured with VUV ellipsometry is shown (right). In addition, the VUV-VASE can measure transmitted intensity to ensure the material quality does not introduce light absorption at the exposure wavelength. The VUV is also used to study coating damage from irradiation.

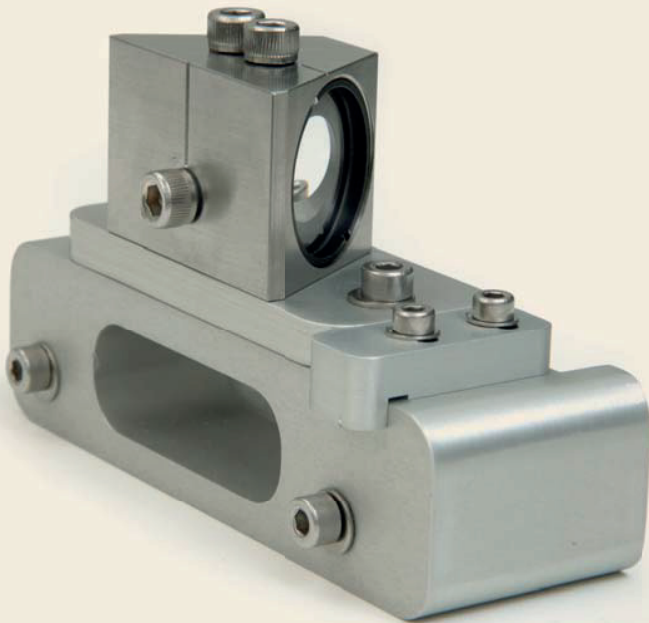
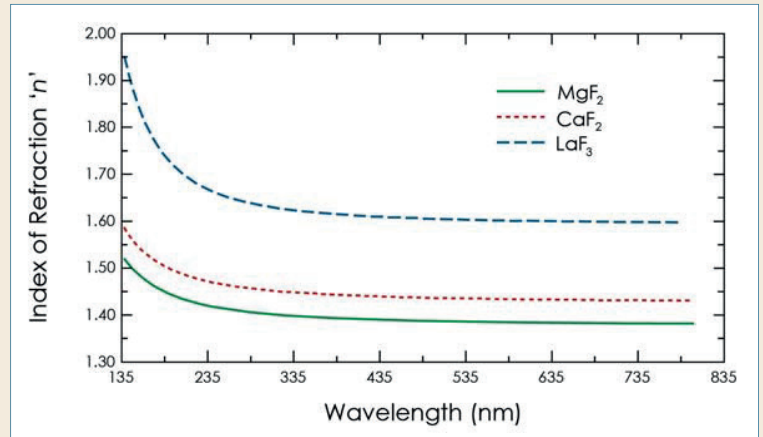

LIQUID PRISM CELL

Immersion Lithography offers significant improvements to extend traditional photolithography to smaller dimensions. The index and extinction coefficient (n and k) are important for the overall optical design.

The VUV-VASE can be enhanced with a hollow-prism cell and special measurement algorithm to determine the optical properties of a liquid. This is achieved via the minimum deviation method. Results are shown for a series of immersion fluids.*

*R.A. Synowicki et al., *Semiconductor FabTech*, 22 (2005) 55.

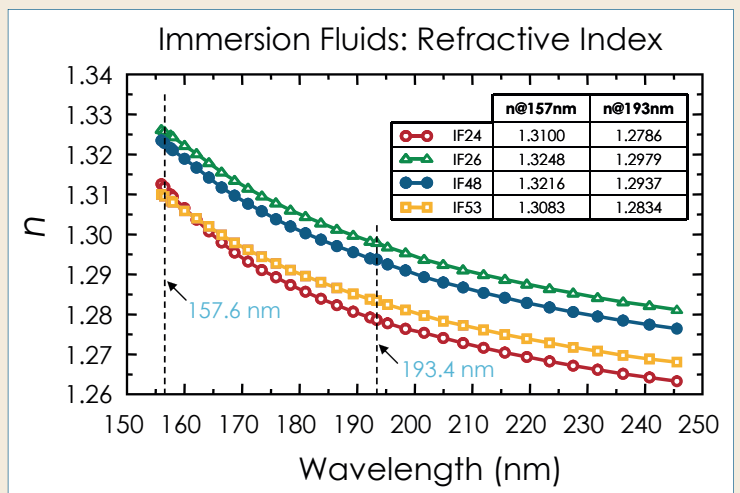
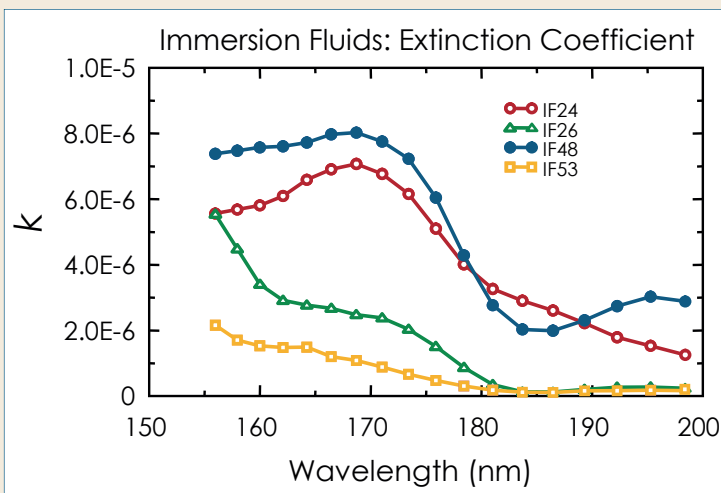

DIMENSIONS

GEN-I

Weight	1050 lbs (480 kg)
Floor Space	<ul style="list-style-type: none"> • 8' (240cm) wide, min. • 6.75' (200cm) deep (Includes space for operator in front)
Ceiling Height	8' (240cm) min.
Electrical Power	100-120 VAC/15A, 200-240 VAC/8A

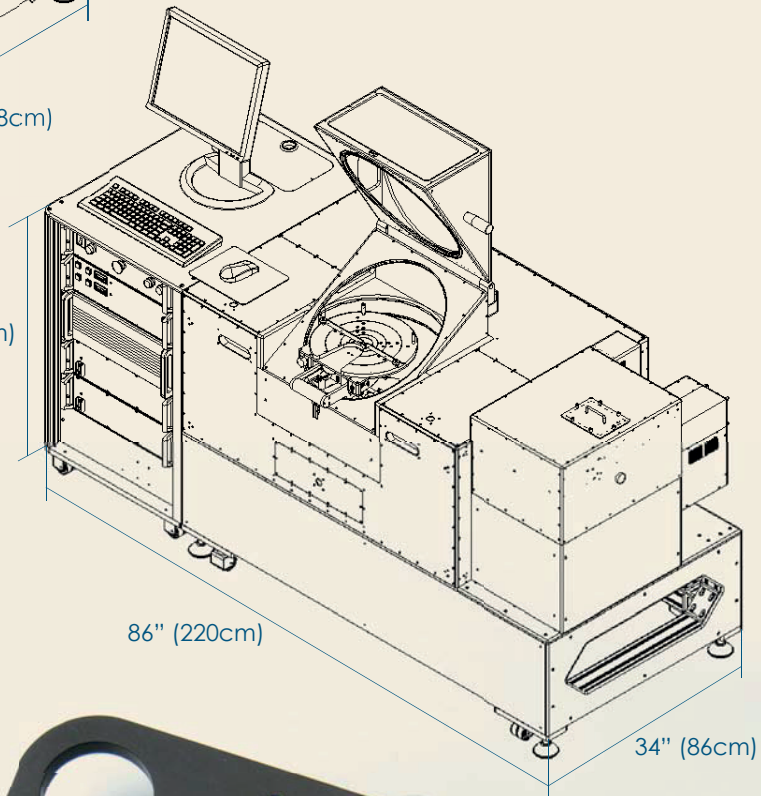
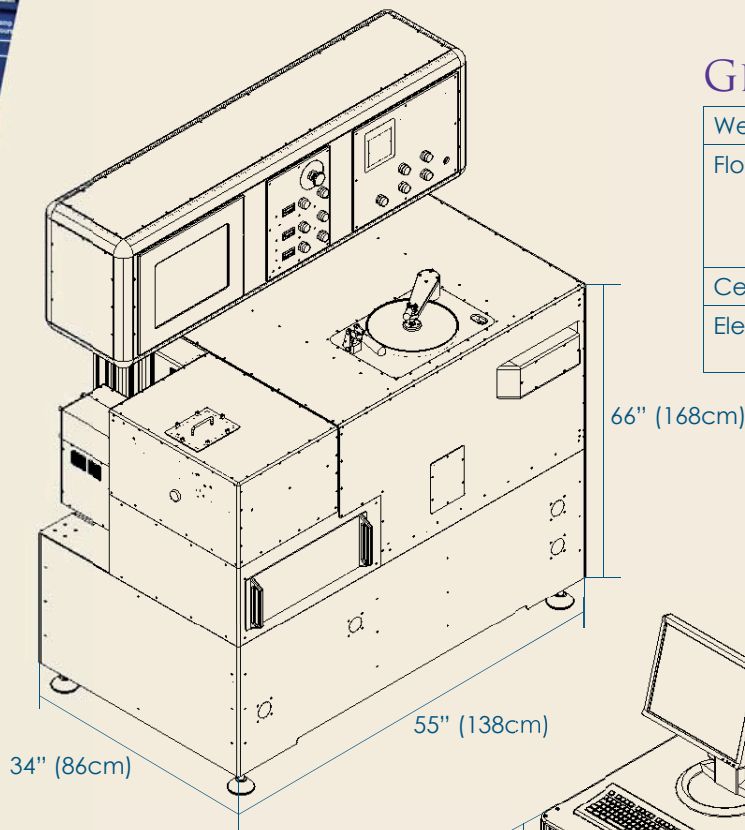

GEN-II

Weight	1600 lbs (725 kg)
Floor Space	<ul style="list-style-type: none"> • 9' (280cm) wide, min. • 6.75' (200cm) deep (Includes space for operator in front)
Ceiling Height	8' (240cm) min.
Electrical Power	100-120 VAC/15A, 200-240 VAC/8A

Gen-I
Photomask
Sample
Holder

