

Model 155 Precision I/V source MeasureReady™



*An ultra-low noise, high-precision
current/voltage source for scientific
and other demanding applications*

Model 155 Precision I/V source MeasureReady™

Built for Science. Designed for People.



*DC-low noise
performance without
compromising
AC bandwidth*

MeasureReady™ 155 Source features

- Bipolar, 4-quadrant I/V source
- DC and AC modes, up to 100 kHz*
- Full scale ranges—voltage: 10 mV to 100 V, current: 1 μ A to 100 mA
- 0.001% programming resolution (from 100 nV/10 pA)
- In-phase reference output for use with a lock-in amplifier (155-AC only)
- Ultra-low noise: from 200 nV/7 pA RMS
- Manual and autorange function
- Front and rear output connectors
- Touchscreen user interface
- 3-year standard warranty

*MeasureReady 155-AC



Full connectivity

Wi-Fi, USB, and LAN connectivity provide convenient integration with systems using LabVIEW™, IVI.NET, and other software. Interfacing is straightforward using IVI-class drivers and industry-standard SCPI commands.

The MeasureReady™ 155 Precision I/V source combines premium performance with unprecedented simplicity for materials scientists and engineers requiring a precise source of current and voltage.

With extensive experience in low-noise instrumentation for research, Lake Shore has leveraged the latest electronic technologies to reduce in-band and out-of-band noise floors for the MeasureReady 155 source to levels previously only possible using add-on filters. The result is a combination AC/DC current and voltage source that is well-suited to the challenges of characterizing sensitive materials and devices, where lower excitation signals are needed and minimum injection of noise into the measurement is required.

While sophisticated on the inside, the 155 is uncommonly straightforward to operate. Leading product designers observe that simple is much harder to accomplish than complex — just putting a touchscreen on a complex product doesn't make it simpler. Lake Shore's modern, user-focused design for the MeasureReady 155 presents an uncluttered and intuitive interface that instantly feels familiar and natural to anybody who owns a smartphone.

From precision thermometry to advanced measurement

For decades, Lake Shore has advanced science by providing cryogenic temperature and magnetic instrumentation to researchers and engineers. At the heart of these instruments are special low-noise current and voltage sources that excite the attached sensors. This has led us to develop ultra-low noise voltage and current sources as standalone instruments for a wider range of demanding applications. The all-new design of the 155 source offers premium performance, easy operation, and modern convenience, backed by Lake Shore's quality and service.

Model 155 Precision I/V source MeasureReady™

See and operate more easily with TiltView™

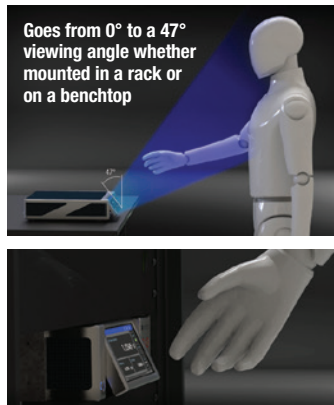

Maximum angle of operation comparison

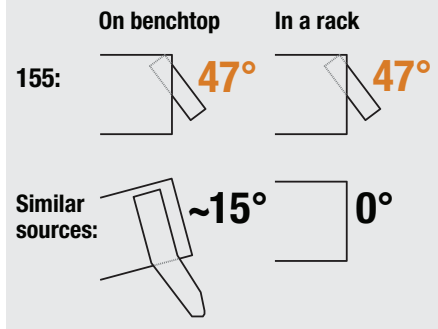

This unique feature makes seeing the screen and operating the touch interface comfortable from any angle, even when mounted in a rack.

For applications where noise matters

The MeasureReady 155 is designed for demanding scientific and engineering applications, where a high-quality, low-noise source of current or voltage is required, such as:

- Precision DC I-V and C-V curve measurements of novel materials and early-stage devices
- AC impedance measurements
- Accurate resistance, magneto-resistance, and resistivity measurements
- Low-noise bias voltages/currents for characterizing new heterostructures
- High-accuracy device testing
- Very low power excitation of sensitive materials like organics
- Controlled characterization of low resistance and superconducting materials
- Low-noise excitation of sensors for improved measurement accuracy
- Hall effect measurements to determine carrier concentrations/mobilities
- Variable temperature device/material characterization using a cryogenic probe station
- Sensitive electrochemical experiments

A perfect pair

Combined with a quality digital meter such as the Keysight 34420A, the 155 I/V source provides greater measurement flexibility and performance when compared to some traditional all-in-one source-measure units (SMUs):

- The ability to select the meter performance best suited to experiment needs
- The ability to measure at contact points independent of the source contacts
- Well-suited to cryogenic probing, using standard or quasi-Kelvin probes
- Simple triggering link available between the 155 and meter



MeasureReady™ 155 rear panel

- | | | |
|---|----------------------------|--------------------------------|
| 1 Triaxial output connector | 3 TTL digital I/O port | 6 USB communications interface |
| 2 BNC output connector | 4 WLAN input | 7 USB thumb drive interface |
| 3 Safety interlock terminal block connector | 5 RJ-45 Ethernet interface | 8 Line input assembly |
| 4 Reference output connector | | |

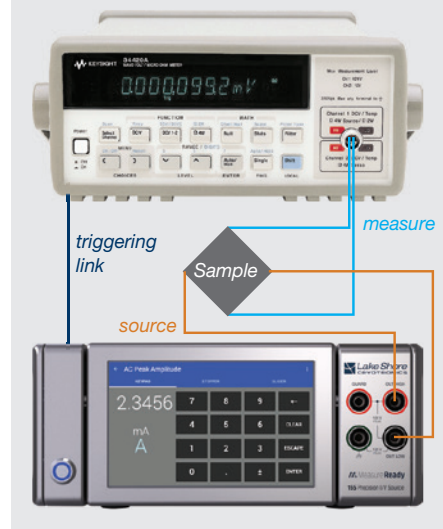

Model 155 Precision I/V source MeasureReady™

Lower noise for better measurements

No filters needed

Characterization of sensitive new electronic materials often requires both AC and DC excitation signals, with source noise directly impacting measurement sensitivity.

To ensure high performance and functionality in an AC source, typically DC noise performance is compromised (and vice versa) because the filtering most often used to quiet DC noise also dampens AC signals and affects stepping and pulse width modulation. The 155 was purposefully engineered to achieve low-noise levels without additional filtering, enabling exceptional output performance in both DC and AC modes.

In side-by-side tests, the 155 demonstrated a cleaner output signal with a lower noise floor than other commercial sources costing far more. That's a key reason why the 155 provides a solid foundation for researchers performing I/V curve, Hall effect, resistance, resistivity, and other fundamental measurements of novel materials and early-stage devices.

Uncompromised noise performance

The 155 generates just 200 nV RMS (1 μ V p-p) of low frequency (<10 Hz) noise and 9 μ V RMS of higher frequency (10 Hz to 100 kHz) noise in the 10 mV range. With a programming resolution of 100 nV, the 155 is ideal when a very clean, ultra-low voltage output is required. For low current signals, the 155 is equally capable — just 7 pA RMS of low frequency noise and a very low 1 nA RMS of higher frequency noise in the 1 μ A range, with a 10 pA setting resolution.

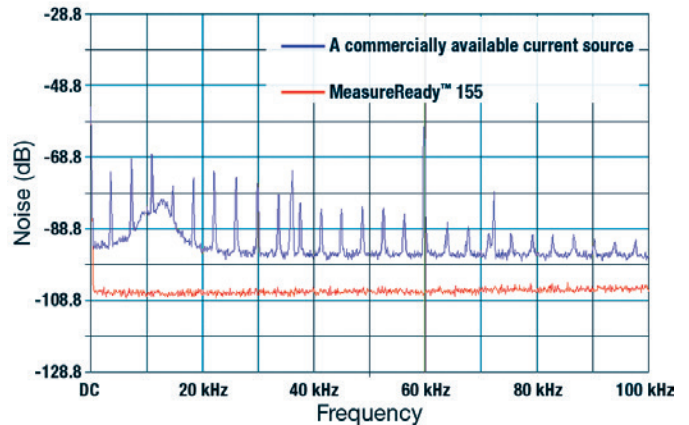

Comparison of the MeasureReady 155 (red) to another commercial current source (blue) at 100 mA into a 100 Ω resistor. The noise (in dB) is shown as a function of frequency from DC to 100 kHz. The noise spectrum of the blue trace clearly shows harmonics occurring at \sim 5 kHz intervals. Adding this type of noise to a measurement will require a larger number of data points to be averaged.

As easy to use as your smartphone

Made for the way you work today, the MeasureReady 155 source features an uncluttered touch display with a unique TiltView™ screen, presenting a natural and engaging user interface.

With no confusing buttons or long learning curves, the 155 is simple and intuitive to operate. You'll quickly recognize the icons, gestures, and menu styles that follow familiar smartphone technology standards.

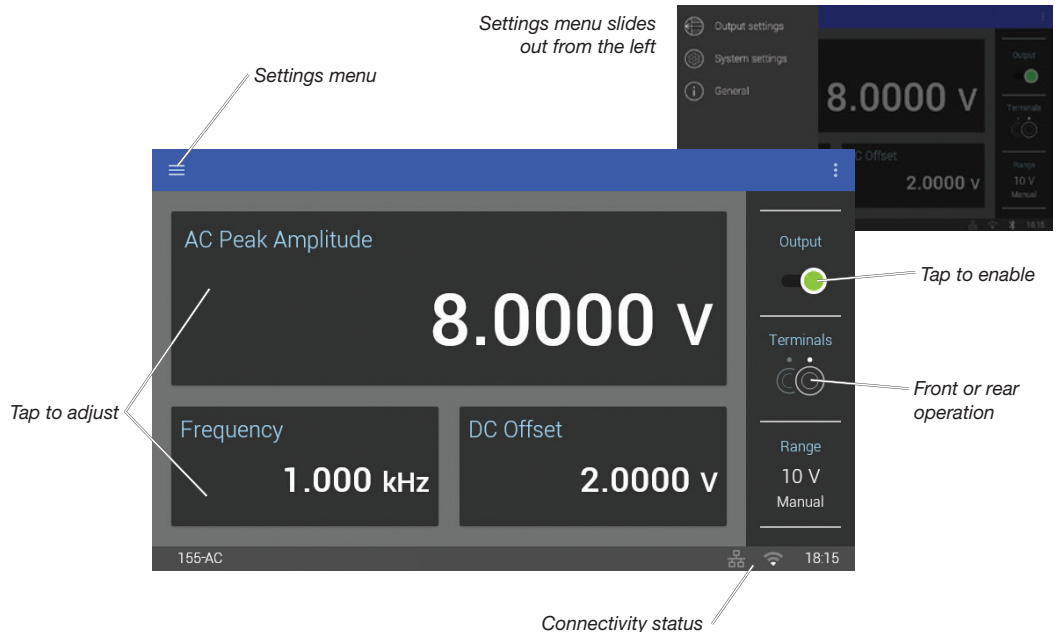

Model 155 Precision I/V source MeasureReady™

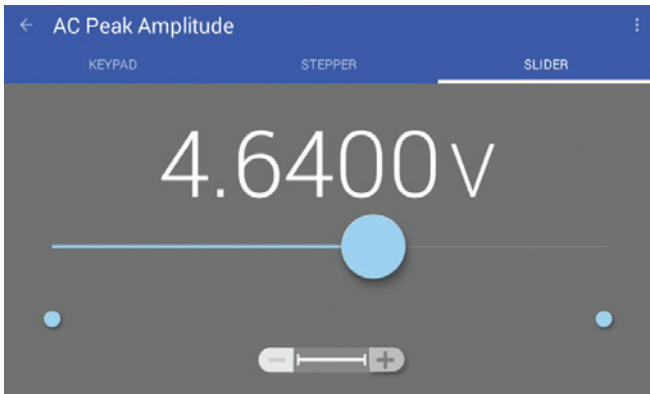

The MeasureReady 155 offers multiple ways to adjust settings, including a “slider” control for fast adjustments. You can use the zoom control (below main slider) for more precise control.

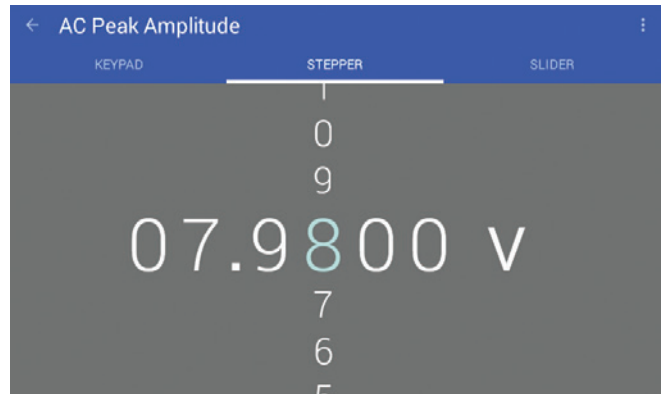

Swiping up or down on the screen allows single digit adjustments using the “stepper” control for slower, incremental changes.

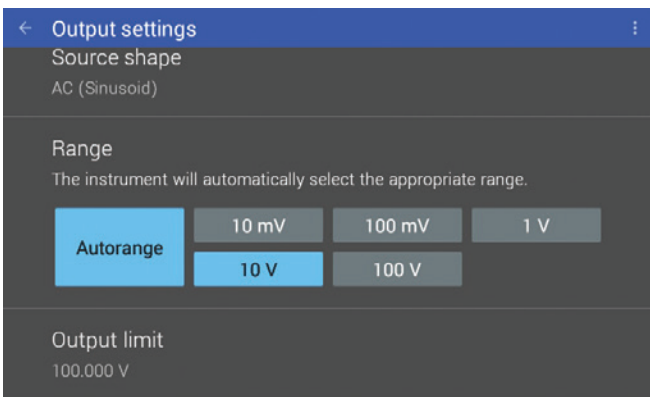

Changing settings is simple and intuitive.

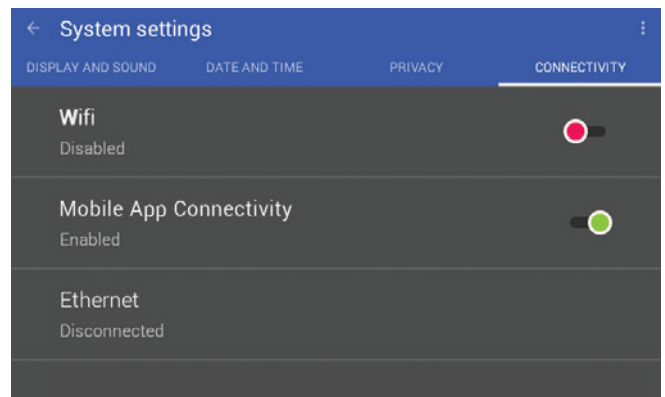

155 connectivity includes wireless alternatives.

Portrait orientation



Need more space on your lab bench? Turn the 155 vertically and the display adjusts automatically.

Convenient remote operation

Installing the free app on your Android device allows you to operate the 155 remotely, whether in the same room or farther away. The app mirrors the 155's front panel interface.

The app is available on Google Play (search for Lake Shore 155).



Google Play and the Google Play logo are trademarks of Google Inc.

Model 155 Precision I/V source MeasureReady™

Options

GPIB-LAN-CONVERT GPIB to LAN converter

For applications requiring IEEE-488 communications, this converter plugs into the instrument's LAN port and creates a GPIB-compatible interface. Note that network timing may be affected when using parallel to serial converters. Delays vary with the amount of data transferred and the converter's activity as messages are received.



Be future-ready with MeasureReady

With free online software updates, your instrument can always have the most current capabilities. And as Lake Shore introduces new options in the future, you can purchase and download them to your instrument. This allows the 155 to grow as your measurement needs evolve.

Specifications

Voltage source specifications

DC/peak ranges	Maximum peak current	Maximum peak power	Programming resolution (0.001%)	DC accuracy (1 year) calibration temperature °C ± 5 °C + (% setting + offset) ^{1,7}	AC accuracy (1 year) calibration temperature °C ± 5 °C + (% setting + % range) ^{1,2,3}	Temperature coefficient/°C 10 °C to 35 °C ± (% setting + offset)	Typical noise (pk-pk/RMS) 0.1 Hz to 10 Hz ⁵	Typical noise (pk-pk/RMS) 10 Hz to 100 kHz ⁵
10 mV	100 mA	1 mW	100 nV	0.2% + 140 µV	0.5 % + 0.2% (up to 20 kHz)	0.014% + 2 µV	1 µV/200 nV	45 µV/9 µV
100 mV		10 mW	1 µV	0.055% + 140 µV		0.0014% + 2 µV	1 µV/200 nV	45 µV/9 µV
1 V		100 mW	10 µV	0.045% + 170 µV		0.0007% + 3 µV	1.5 µV/300 nV	45 µV/9 µV
10 V		1 W	100 µV	0.045% + 500 µV		0.0007% + 30 µV	10 µV/2 µV	75 µV/15 µV
100 V	10 mA	1 W	1 mV	0.055% + 6 mV		0.0009% + 300 µV	100 µV/20 µV	750 µV/150 µV

Current source specifications — low voltage compliance

DC/peak ranges	Peak compliance voltage	Maximum peak power	Programming resolution (0.001%)	DC accuracy (1 year) calibration temperature °C ± 5 °C + (% setting + offset) ¹	AC accuracy (1 year) calibration temperature °C ± 5 °C + (% setting + % range) ^{1,2}	Temperature coefficient/°C 10 °C to 35 °C ± (% setting + offset)	Typical noise (pk-pk/RMS) 0.1 Hz to 10 Hz ⁵	Typical noise (pk-pk/RMS) 10 Hz to 100 kHz ⁵
1 µA	10 V	10 µW	10 pA	0.05% + 500 pA	1% + 0.2% (up to 20 kHz)	0.0008% + 4 pA	40 pA/8 pA	10 nA/2 nA
10 µA		100 µW	100 pA	0.05% + 1.5 nA		0.0008% + 40 pA	40 pA/8 pA	10 nA/2 nA
100 µA		1 mW	1 nA	0.05% + 15 nA		0.0008% + 400 pA	200 pA/40 pA	10 nA/2 nA
1 mA		10 mW	10 nA	0.05% + 150 nA		0.0008% + 4 nA	2 nA/400 pA	20 nA/4 nA
10 mA		100 mW	100 nA	0.055% + 2.5 µA		0.0008% + 40 nA	20 nA/4 nA	200 nA/40 nA
100 mA		1 W	1 µA	0.1% + 70 µA		0.0008% + 400 nA	200 nA/40 nA	2 µA/400 nA

Current source specifications — high voltage compliance

DC/peak ranges	Peak compliance voltage	Maximum peak power	Programming resolution (0.001%)	DC accuracy (1 year) calibration temperature °C ± 5 °C + (% setting + offset) ¹	AC accuracy (1 year) calibration temperature °C ± 5 °C + (% setting + % range) ^{1,2}	Temperature coefficient/°C 10 °C to 35 °C ± (% setting + offset)	Typical noise (pk-pk/RMS) 0.1 Hz to 10 Hz ⁵	Typical noise (pk-pk/RMS) 10 Hz to 100 kHz ⁵
1 µA	100 V	100 µW	10 pA	0.08% + 500 pA	1% + 0.2% (up to 20 kHz)	0.0025% + 4 pA	35 pA/7 pA	5 nA/1 nA
10 µA		1 mW	100 pA	0.08% + 1.5 nA		0.0025% + 40 pA	35 pA/7 pA	5 nA/1 nA
100 µA		10 mW	1 nA	0.08% + 15 nA		0.0025% + 400 pA	250 pA/50 pA	5 nA/1 nA
1 mA		100 mW	10 nA	0.08% + 150 nA		0.0025% + 4 nA	2.5 nA/500 pA	40 nA/8 nA
10 mA		1 W	100 nA	0.08% + 1.5 µA		0.0025% + 40 nA	25 nA/5 nA	400 nA/80 nA

¹ Calibration temperature is the ambient temperature during factor calibration, typically, 23 °C; reported by the instrument

² Specification guaranteed on the rear panel only

³ Guaranteed into load no greater than 100 pF

⁴ Loads for current settle time: 100 mA range: 100 Ω, 1 mA and 100 µA ranges: 10 kΩ, 10 µA, and 1 µA ranges: short

⁵ Representative values

⁶ Measured into 10 Ω resistor for 100 mA and 10 mA ranges with compliance voltage < 10 V; measured into transimpedance amplifier with 1 kΩ feedback resistor for other cases

⁷ Calibrated into >10 GΩ load

Model 155 Precision I/V source MeasureReady™

Additional specifications

Output selection modes	Voltage or current
Range selection modes	Manual, autorange
Current source compliance selection	10 V or 100 V
Programmable limits (DC only)	I out: compliance voltage, V out: current limit
Accuracy	Positive output: +5%/-0% of setting (when setting is $\geq 10\%$ of its full-scale range) Negative output: -5%/+0% of setting (when setting is $\geq 10\%$ of its full-scale range)
Programming resolution	Current limit: 0.1% of full-scale current range (auto selected) Voltage limit: 10 mV (10 V compliance), 100 mV (100 V compliance)
Polarity	Bipolar, 4-quadrant
Load impedance	Capable of driving any resistive load within the I and V limitations of the source; stability maintained with reactive loads up to 50 μ F or 1 mH (with 100 Ω damping)
AC frequency range	100 mHz to 100 kHz
AC frequency accuracy	$\pm 0.06\%$
AC signal types	Sine
Total harmonic distortion	$< 0.1\%$ from DC to 20 kHz, $< 1\%$ from 20 kHz to 100 kHz
Sample rate	600 kilosamples per second
Noise (10 Hz to 40 MHz)^{2,5}	Voltage: ≤ 700 μ V RMS, across all ranges Current: ≤ 8 μ A RMS (400 μ V RMS across 50 Ω), across all ranges
Load regulation²	Voltage: 10 V range and below: $< 0.2\%$ of range, 100 V range: $< 0.01\%$ of range; Current: 10 V compliance: $< 0.01\%$ of range, 100 V compliance: $< 0.01\%$ of range
Settling times	Voltage: time to reach final value at open load condition: 25 μ s Current: time to reach final value into a given load ⁴ : 25 μ s
Output lead connections	Output HI, Output LO, Guard, Chassis Ground
Connector type	Front: safety banana jack Rear: BNC or triaxial (user selectable between front and rear panel)
Guard output	Maximum load current: 1 mA peak
Power up protection	Output terminals floating on power up
Additional output features	User-specified output setting limit, enable/disable output setting
Warm-up time	30 min (to achieve specified accuracy)
Isolation	Source output isolated from chassis ground
Output capacitance	Front: < 100 pF, rear: < 50 pF
Reference output	
Signal type	Synchronous with the source output signal, referenced to chassis ground
Amplitude	0 to +3.3 V nominal
Accuracy⁵	Voltage: $\pm 3^\circ$, up to 10 kHz Current ⁶ (≥ 100 μ A range): $\pm 4^\circ$, up to 10 kHz
Phase compensation	180.0° to +180.0° with 1° resolution
Connector	BNC
Waveform	Square wave

LabVIEW™ is a trademark of National Instruments. Neither Lake Shore Cryotronics, nor any software programs or other goods or services offered by Lake Shore, are affiliated with, endorsed by, or sponsored by National Instruments.

Front panel

Display 5 in capacitive touch, color TFT-LCD WVGA (800 × 480) with LED backlight

Interface

USB host

Type	USB 3.0, mass storage class (MSC) device
Function	Firmware updates, flash drive support
Location	Rear panel
Connector	USB Type-C™

USB device

Type	USB 2.0
Function	Emulates a standard RS-232 serial port
Protocol	Standard commands for programmable instruments (SCPI)
Baud rate	115,200
Connector	USB Type-B
Software support	LabVIEW™ and IVI.NET drivers (see www.lakeshore.com)

Ethernet

Function	TCP/IP command and control, mobile app
App. layer protocol	Standard commands for programmable instruments (SCPI)
Connector	RJ-45
Speed	1 Gb/s
Software support	LabVIEW™ and IVI.NET drivers (see www.lakeshore.com)

Wi-Fi

Type	802.11 b/g/n
Function	TCP/IP command and control, mobile app
App. layer protocol	Standard commands for programmable instruments (SCPI)
Antenna	External, coaxial
Software support	LabVIEW™ and IVI.NET drivers (see www.lakeshore.com)

Wireless personal area network (WPAN)

Function	Short-range, wireless interconnection for mobile app
Antenna	External, coaxial

Digital IO

Connector	6-pin 3.5 mm detachable terminal block
Output	2 TTL compatible output (3.3 V _{high} nominal at 1 mA)
Input	2 TTL compatible input; V _{high} nominal: 3.3 V; V _{low} nominal: 0 V
Grounding	Referenced to chassis ground

General

Safety interlock	2-pin 5.0 mm detachable terminal block, maximum 10 Ω external circuit impedance
Ambient temperature	10 °C to 35 °C at rated accuracy; 5 °C to 40 °C at reduced accuracy
Power requirement	100 V to 240 V (universal input), 50 to 60 Hz, 30 VA
Size	217 mm W × 87 mm H × 369 mm D (8.5 in × 3.4 in × 14.5 in), half rack
Weight	3.2 kg (7 lb)
Approval	CE mark
Wireless approvals	FCC: TFB-TIW1-01, IC: 5969A-TIW101, Giteki: G209-J00157

Model 155 Precision I/V source MeasureReady™

Ordering Info

MeasureReady™ 155 Sources

- 155-AC Precision I/V source for AC and DC operation—
includes calibration certificate and 155-ACC-KIT
- 155-DC Precision I/V source for DC operation only—
includes calibration certificate and 155-ACC-KIT

Options

- GPIB-LAN-CONVERT GPIB to LAN converter; enables GPIB communications and control of a LAN instrument; GPIB data transfer rates not guaranteed and will be limited by LAN transfer rates

Accessories

- 155-ACC-KIT MeasureReady 155 accessory kit (included with new instruments); includes quick start guide, USB-A to USB-C adapter, two 6-pin IO connectors, power cord, and one 2-pin interlock connector
- RMX-FULL Kit for mounting two 1/2 rack (or one full rack) XIP instruments in a 483 mm (19 in) rack
- RMX-HALF Kit for mounting one 1/2-rack XIP instrument in a 483 mm (19 in) rack
- G-106-735 2-pin voltage interlock connector with shorting connection (allows operation over 10 V)
- G-106-741 6-pin green Phoenix terminal block
- 119-155 MeasureReady 155 user manual
- CAL-155-CERT MeasureReady 155 recalibration with certificate
- CAL-155-DATA MeasureReady 155 recalibration with certificate and data

RMX-FULL

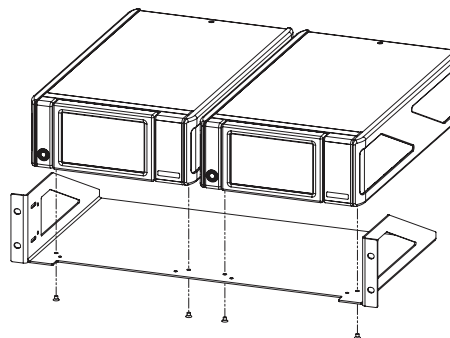

RMX-HALF

