

A practical guide to minimizing the effect of common-mode noise interference in low-temperature applications

J. R. Lindemuth and E. A. Codecido, Lake Shore Cryotronics

Application Note

APPLICATION NOTE

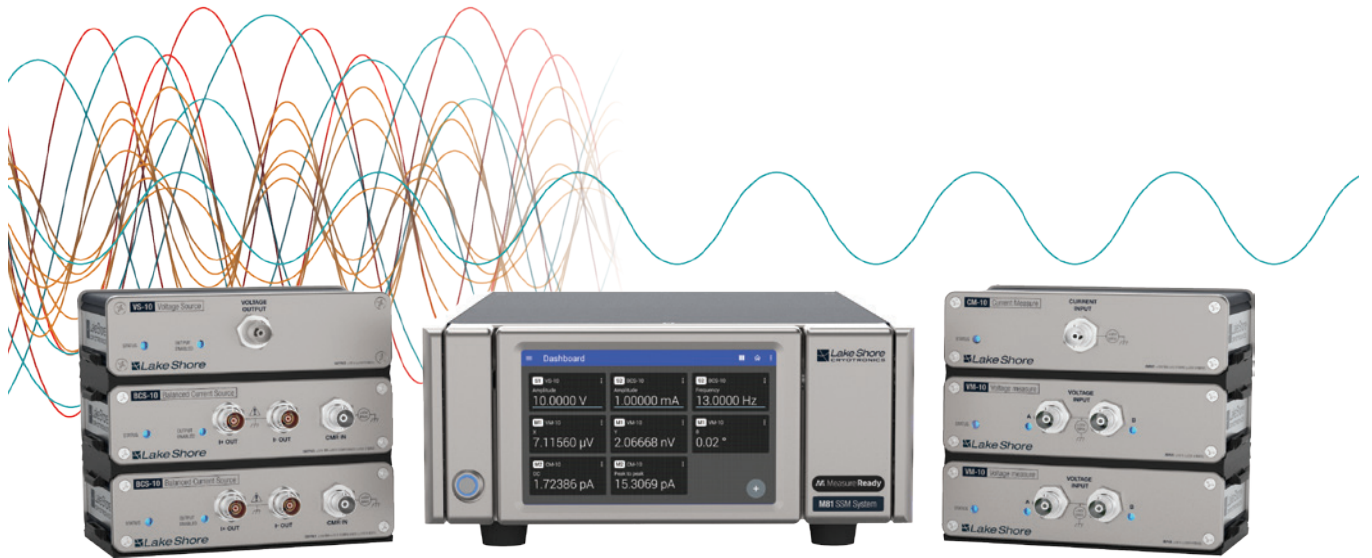

A practical guide to minimizing the effect of common-mode noise interference in low-temperature applications

J. R. Lindemuth and E. A. Codecido, Lake Shore Cryotronics

Application Note



Introduction

The MeasureReady™ M81-SSM Synchronous Source Measure System provides a true balanced current source module, the BCS-10. Most other commercial current sources are single-ended type sources. The low connection (current return) of these types of current sources is at measure ground by design. The measurement instrument attached to the current source sees different impedances looking back into each side of the current source. This will generate common-mode signals that are converted to differential signals in the preamp of the measurement modules and result in measurement error.

The BCS-10 module uses technology based on Lake Shore's expertise with balanced current sources used in the Model 370 and 372 AC resistance bridges. When coupled with the common-mode rejection (CMR) feature, the balanced current source provides additional accuracy and noise reduction in a wide variety of applications. This application note will explain the advantages and best practice usage of the CMR feature of the M81-SSM BCS-10 module.

An external CMR input connection is a new feature of the BCS-10 module not present on the Model 372 bridge. The external CMR input of the BCS-10 is typically used in conjunction with a VM-10 voltage measurement module to improve the accuracy and lower the noise of the VM indication. We begin with a simple review of ideal differential amplifier behavior and how common-mode signals affect practical differential amplifiers.

Definition of common-mode signal and differential signal

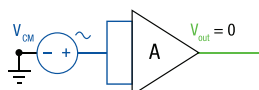

Figure 1 Ideal differential amplifier with $CMR = \infty$

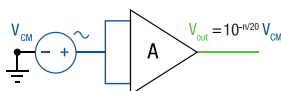

Figure 2 Practical differential amplifier with $CMR = n \text{ dB}$

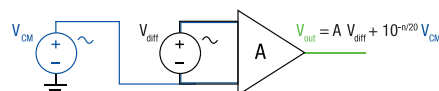

Figure 3 A practical differential amplifier with differential input, common-mode signal, and finite CMRR

An ideal differential amplifier will have zero output if the inputs have the same voltage. In this case, the common-mode rejection ratio (CMRR) is infinite.

A practical differential amplifier will have a finite common-mode rejection ratio and hence will have an output even if the inputs have the same voltage. CMRR is typically specified in dB and is $20 \log(V_{CM}/V_{out})$.

The signal of interest is the differential input (V_{diff}), and the output of a practical differential amplifier is then

$$V_{out} = A V_{diff} + 10^{-n/20} V_{CM}$$



A practical guide to minimizing the effect of common-mode noise interference in low-temperature applications

J. R. Lindemuth and E. A. Codecido, Lake Shore Cryotronics

Application Note



Comparison of a single-ended current source to a differential current source and the BCS-10 differential current source with external CMR

A single-ended current source will have the current return connection tied to measurement ground

In Figure 4, R_1 and R_3 represent the lead resistance from the current source to the DUT (R_2). In addition, resistance R_{1c} and R_{3c} represent the contact resistance of the connections to the DUT. These resistances are in series with the lead resistance and always add to the lead resistance. In many cases, the contact resistance can be much larger than the lead resistance. For instance, contacts to graphene can have a contact resistance of 1000Ω or more.

Resistors R_4 and R_5 represent the lead resistance of the connection to the differential amplifier (input to the voltmeter). Since the input of the differential amplifier is assumed to be infinite (for low-frequency measurements), no current will flow through these resistors. Their value is of no consequence, and the voltage drop across R_4 or R_5 is zero.

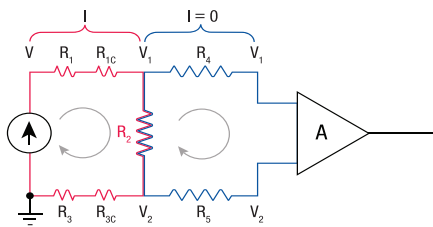

Figure 4 Single-ended current source

We can now write Kirchhoff's law around the loop and solve for the differential and common-mode voltage:

$$\begin{aligned}
 V &= I(R_1 + R_{1c} + R_2 + R_3 + R_{3c}) \\
 V_1 &= V - I(R_1 + R_{1c}) \\
 V_2 &= I(R_3 + R_{3c}) = V - I(R_1 + R_{1c}) - IR_2 \\
 V_{diff} &= V_1 - V_2 = IR_2 \\
 V_{cm} &= (V_1 + V_2)/2 = V_{diff}/2 + I(R_3 + R_{3c})
 \end{aligned}$$

A balanced differential current source with internal CMR

If we replace the single end current source with a differential current source (as seen in Figure 5), we can reduce the common-mode signal. The differential current source uses internal feedback to keep the compliance voltage of the two current sources equal and opposite. This is labeled as $V/2$ and $-V/2$ in Figure 5.

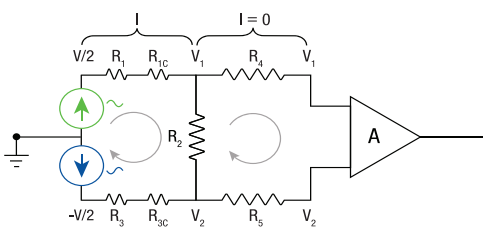

Figure 5 Differential current source, internal CMR

Note that if $R_1 + R_{1c} = R_3 + R_{3c}$, the circuit is symmetrical, and the common-mode signal is zero. In practice, this is very difficult to achieve.

Now the ground is between the two current sources. The top current source is sourcing a current, I , and the bottom current source is sinking the same current. The voltage required to source or sink the currents are $V/2$ and $-V/2$, respectively. Solving Kirchhoff's law now gives:

$$\begin{aligned}
 V_1 &= V/2 - I(R_1 + R_{1c}) \\
 V_2 &= -V/2 + I(R_3 + R_{3c}) \\
 V_{diff} &= V/2 - I(R_1 + R_{1c}) - (-V/2 + I(R_3 + R_{3c})) \\
 &= V - I(R_1 + R_{1c} + R_3 + R_{3c}) \\
 &= IR_2 \\
 2 V_{cm} &= V/2 - I(R_1 + R_{1c}) + (-V/2 + I(R_3 + R_{3c})) \\
 &= I((R_3 + R_{3c}) - (R_1 + R_{1c})) \\
 V_{cm} &= [I((R_3 + R_{3c}) - (R_1 + R_{1c}))]/2
 \end{aligned}$$

A practical guide to minimizing the effect of common-mode noise interference in low-temperature applications

J. R. Lindemuth and E. A. Codecido, Lake Shore Cryotronics

Application Note



A balanced differential current source with external CMR connection

If we now make the differential current source a balanced differential current source with an external CMR connection (see Figure 6), we can reduce the CMR and not depend on symmetry in the circuit. In this mode, the low side of the differential amplifier is connected to the external CMR connection. The common point of the two current sources is no longer at 0 V. The compliance voltage of the two current sources (V_0 and $-V_3$ in Figure 6) are adjusted to make $V_2 = 0$ V.

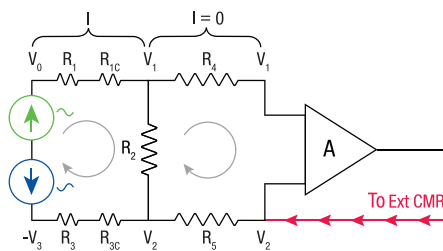

Figure 6 Balanced differential current source

Solving Kirchoff's equation for this case gives:

$$V_1 = V_0 - I(R_1 + R_{1c}) = IR_2$$

$$V_2 = 0 \text{ Note this is not ground but rather an actively driven } 0 \text{ V, } V_2 \text{ is driven to } 0 \text{ V using the external CMR connection}$$

$$V_{diff} = V_1 - V_2 = IR_2$$

$$V_{cm} = (V_1 + V_2) / 2 = IR_2 / 2$$

$$V_0 = I(R_2 + R_1 + R_{1c})$$

Now the common-mode signal is $\frac{1}{2}$ of the differential voltage. The common-mode error is $10^{-20}(IR_2/2)$.

Low-resistance measurement in a cryostat with long leads to the sample

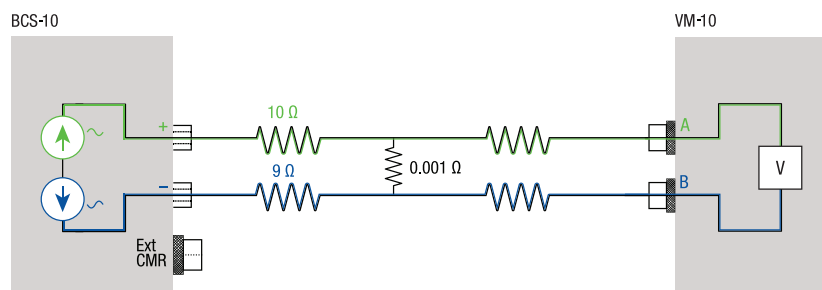

Figure 7 Measurement of a 0.001 Ω resistor in a cryostat. BCS-10 module has triaxial connectors whereas the VM-10 has BNC connectors

Our first example is a measurement of a 1 m Ω resistance. The sample is in a cryostat, so long leads to the sample are required. It is often the case that the resistances of the leads to the sample are not the same. In addition, any difference in the contact resistance of the lead attachments to the sample will also contribute to this resistance difference. For example, the difference between contacts in graphene can easily be ~ 1 k Ω . The sample is measured in the four-wire configuration to remove the effect of the lead resistance (Figure 7). For this example, we will assume the connection on the I+ of the BCS-10 is 10 Ω , and the connection to the I- of the BCS-10 is 9 Ω . The input impedance of the VM is very high, so we can assume no current flows in the leads to the VM; therefore, those lead resistances are of no consequence. We will assume using 100 mA of current for the measurement.

The signal of interest to the VM is $0.1 \text{ A} * 0.001 \Omega = 100 \mu\text{V}$. The 1 Ω difference in the resistance will create a common-mode voltage = $[I((R_3 + R_{3c}) - (R_1 + R_{1c}))] / 2 = 0.1 \text{ A} * 1 \Omega / 2 = 50 \text{ mV}$. If the CMRR of the VM is 80 dB (a reasonable value for a VM up to about 1000 Hz) the indication on the VM from the common-mode voltage is $0.05 * 10^{-4} = 5 \mu\text{V}$. The total indication of the VM is then 105 μV , or a 5% error.

A practical guide to minimizing the effect of common-mode noise interference in low-temperature applications

J. R. Lindemuth and E. A. Codecido, Lake Shore Cryotronics

Application Note

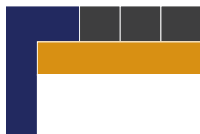

Using the external CMR input of the BCS-10

The BCS-10 module has an additional feature to allow the balanced current source to reduce the common-mode voltage. This is accomplished with an additional input, labeled the external CMR. This input is connected to the low node of the voltage measurement module. The BCS-10 will adjust the common-mode current to drive the point to 0 V. Typically, the CMR input is connected to the low side of the VM-10 module, which is operated in differential (A-B) mode.

In Figure 8, the VM-10 is now presented with only $50 \mu\text{V}$ ($IR_2/2$) of common-mode. The common-mode signal on the output is 5 nV , or 0.005% of the correct value.

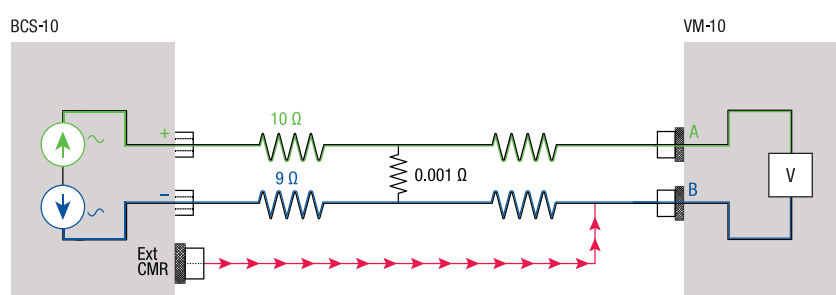

Figure 8 Adding a connection to the external CMR input of the BCS-10

Common-mode noise

In the examples presented so far, the common-mode signal is generated by the BCS-10 current and produces an error in the reading of the VM. Another source of common-mode signal comes from external signals and external noise sources. In Figure 3, the V_{CM} signal can be generated from ground loops in the measurement setup that induce line frequency signals and other spurious signals at other frequencies. This signal is in the output of the differential amplifier but will be common-mode noise. The BCS-10 external CMR feature will reduce the common-mode noise just like it reduces the common-mode signal in the Figure 8 example.

Using the BCS-10 with two VM-10 modules

Sometimes, when measuring the Hall effect on a Hall bar sample, there are two VM-10 modules in the measurement. The advantage of this is that you can simultaneously measure the resistance and the Hall voltage. In Figure 9, we show the external CMR input connected to the common V- inputs of the two VM-10 modules.

If your measurement configuration uses more than one VM and the V- connections are not tied to a common point, connect one of the V- connections to the BCS-10 external CMR input.

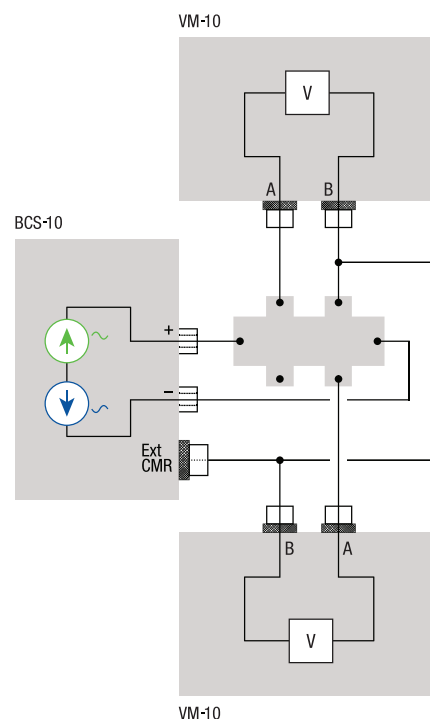

Figure 9 Measuring a Hall bar sample with one BCS-10 and two VM-10 modules using external CMR

A practical guide to minimizing the effect of common-mode noise interference in low-temperature applications

J. R. Lindemuth and E. A. Codecido, Lake Shore Cryotronics

Application Note



When not to use CMR

There is one configuration where you do not want to use the CMR function.

If you want to use a current measurement module (CM-10) to measure the current from the BCS-10, then since the CM input is a virtual ground, you must ground the I- output of the BCS-10 as shown in Figure 10. This effectively converts the balanced current output of the BCS-10 to a single-ended current source. In this case, the CMR function must be turned off.

When to use CMR?

Common-mode rejection (CMR) should always be used to reduce common-mode amplification. The two primary sources of common-mode signals come from 1) ground loops or external noise pick-up and 2) imbalance in the current leads. Unless the I- output of the BCS-10 is grounded, the CMR should always be set to either internal or external.

Ground loops or external noise pick-up

Ground loops, RF noise, 60 Hz signal pick-up, etc., are sources of common-mode signal that can add error to a sensitive measurement. These sources shift the signal of interest at the amplifier and introduce error from the common-mode gain. Implementing an external CMR connection can significantly reduce this error by providing feedback to the BCS-10 module to null the common-mode signal at the amplifier.

Imbalance in the current leads

An imbalance in the resistance of the current leads, which includes the contact resistance in the sample, also offsets the signal of interest and adds error from the common-mode gain. As shown in Figure 11, CMR is particularly important under conditions when the load resistance is much smaller than the resistance imbalance from the current leads. For example, highly conductive or superconducting samples with differences in the contact resistance in the order of 10^3 to $10^4 \Omega$ (which can easily be the case for graphene and other 2DEG materials) contain errors on the order of 5% or larger if CMR is unused. Applying an external CMR connection is particularly important in such applications.

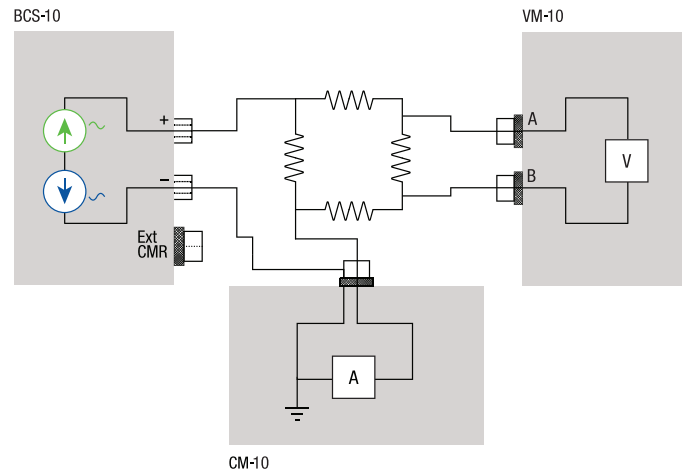

Figure 10 Using a CM-10 with a BCS-10 — do not use the CMR in this case

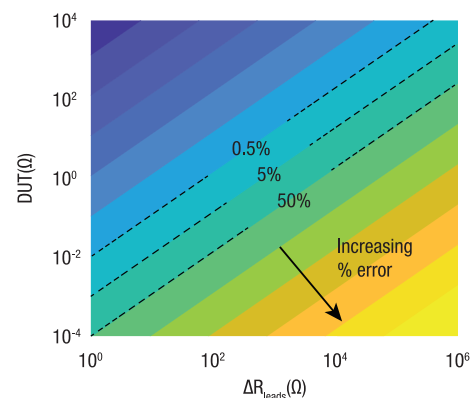

Figure 11 Measurement error resulting from common mode voltage as a function of device resistance and current leads resistance imbalance

A practical guide to minimizing the effect of common-mode noise interference in low-temperature applications

J. R. Lindemuth and E. A. Codecido, Lake Shore Cryotronics

Application Note



Summary

The M81-SSM system provides many unique source and measure capabilities that enhance noise rejection in low-level signal applications, such as differential (balanced) source and measure connections. In addition, the BCS-10 module's CMR function can be used to increase the accuracy of a measurement and decrease the noise of the measurement. Except for the case described in Figure 10, the CMR function should always be used in external mode. Typically, the external CMR connection on the BCS-10 module should be connected to the V- (B) input of a VM-10 module.

A practical guide to minimizing the effect of common-mode noise interference in low-temperature applications

J. R. Lindemuth and E. A. Codecido, Lake Shore Cryotronics

Application Note

Copyright © Lake Shore Cryotronics, Inc. All rights reserved. Specifications are subject to change.

Lake Shore Cryotronics, the Lake Shore logo, the square graph logomark, and Cernox are registered trademarks of Lake Shore Cryotronics, Inc.

All other trade names referenced are the service marks, trademarks, or registered trademarks of their respective companies.

040422

Questions? Answers?

Visit <https://forums.lakeshore.com/> and become part of the conversation!

Lake Shore
CRYOTRONICS

User Group Forum

Home Search Search

Lake Shore > Material Characterization Products > Measurements

Talk to fellow users and Lake Shore experts

Sub-Boards

	Board
	I/V source discussion Discuss Lake Shore I/V source applications, review

