

Hall probes



Hall probe features

- Axial, transverse, multi-axis, and tangential Hall probes for measuring magnetic flux density
- Choose from a wide range of lengths and thicknesses
- Probes also available for cryogenic applications



Hall probes

Stock Probes — Ordering Information

Shown in the tables below are our recommended in-stock Hall probes for use with your gaussmeter. They are the ones most commonly ordered by our customers and require no special configuration. Because they are in stock, they offer shorter lead time when ordered.

For other probes, including versions for tangential, multi-axis, and cryogenic applications, see the specialized probes beginning on the next page. Also, for technical specifications and illustrations related to the probes listed (as well as others in this catalog), see the end of the Hall probes section.

Don't see the probe you need in this catalog? Please contact us. We also offer custom configured Hall probes.

Model	Orientation	Frequency range	Full-scale field ranges	Stem material	Stem length (in)	RoHS	Probe part number
Models 425, 455 and 475	Axial	DC to 400 Hz	HST-4: 35 G, 350 G, 3.5 kG, 35 kG	Aluminum	4	Yes	HMMA-2504-VF
		DC to 800 Hz	HST-4: 35 G, 350 G, 3.5 kG, 35 kG	Fiberglass			HMNA-1904-VF
		DC to 10 kHz	HSE: 3.5 G, 35 G, 350 G, 3.5 kG, 35 kG	Aluminum			HMMA-2504-VR
		DC to 20 kHz	HSE: 3.5 G, 35 G, 350 G, 3.5 kG, 35 kG	Fiberglass			HMNA-1904-VR
	Transverse	DC to 400 Hz	HST-4: 35 G, 350 G, 3.5 kG, 35 kG	Aluminum	4	Yes	HMMT-6J04-VF
		DC to 800 Hz	HST-4: 35 G, 350 G, 3.5 kG, 35 kG	Fiberglass			HMNT-4E04-VF
			HSE: 3.5 G, 35 G, 350 G, 3.5 kG, 35 kG	Aluminum			HMMT-6J04-VR
		DC to 20 kHz	HSE: 3.5 G, 35 G, 350 G, 3.5 kG, 35 kG	Fiberglass			HMNT-4E04-VR

NOTE: The Model 455 is a legacy gaussmeter no longer available from Lake Shore.

Model	Orientation	Frequency range	Full-scale field ranges	Stem material	Stem length (in)	RoHS	Probe part number	
Models 421, 450 and 460	Axial	DC and 10 Hz to 400 Hz	HST-2: 300 G, 3 kG, 30 kG	Aluminum	4	No	MMA-2504-VG	
			HSE-1: 30 G, 300 G, 3 kG, 30 kG	Fiberglass			MMA-2504-VH	
	Transverse	DC and 10 Hz to 400 Hz	DC	HST-2: 300 G, 3 kG, 30 kG	Aluminum	4	No	MMT-6J04-VG
			DC and 10 Hz to 100 Hz	HSE-1: 30 G, 300 G, 3 kG, 30 kG	Aluminum			MMT-6J04-VH
			DC and 10 Hz to 400 Hz	HST-2: 300 G, 3 kG, 30 kG	Fiberglass			MNT-4E04-VG
				HSE-1: 30 G, 300 G, 3 kG, 30 kG	Fiberglass			MNT-4E04-VH
460 only	3-axis	DC and 10 Hz to 400 Hz	HSE-1: 30 G, 300 G, 3 kG, 30 kG	Aluminum	8		MMZ-2508-UH	

NOTE: The Model 421, 450, and 460 are legacy gaussmeters no longer available from Lake Shore.

Model	Orientation	Frequency range	Full-scale field ranges	Stem material	Stem length (in)	RoHS	Probe part number
Model 410	Axial	DC	200 G, 2 kG, 20 kG	Brass	2	No	MSA-2202-410
			200 G, 2 kG, 20 kG	Brass	4		MSA-2204-410
		DC to 10 kHz	200 G, 2 kG, 20 kG	Flexible plastic tubing	2.6		MSA-410
	Transverse	DC	200 G, 2 kG, 20 kG	Brass	2	No	MST-9P02-410
			200 G, 2 kG, 20 kG	Brass	4		MST-9P04-410
		DC to 10 kHz	200 G, 2 kG, 20 kG	Flexible plastic tubing	2.6		MST-410

For the specifications of each probe, please see the individual probe product spec sheets, starting on page 37.

Hall probes

Built-to-Order Probes — Ordering Information

Follow these steps to order the probe you need from the tables on the following pages:

Step 1: Look for the table header identifying your Lake Shore gaussmeter model and your desired field orientation (axial, transverse) or specialized application (tangential, cryogenic, or multi-axis).

Built-to-Order Probes
Axial probes for Model 460, 450, and 421 gaussmeters

Frequency range	Full-scale field ranges	Stem material	Stem diameter (in)	Stem lengths (in)	Probe part number	*
DC	HST-2: 300 G, 3 kG, 30 kG	Aluminum	0.08	02, 04, 08	MMA-08XX-UH	* Cable length can be changed. See below.
	HST-1: 300 G, 3 kG, 30 kG, 300 kG	Aluminum	0.25	04, 36	MMA-25XX-WL	
DC and 10 Hz to 400 Hz	HST-2: 300 G, 3 kG, 30 kG	Aluminum	0.06	02, 04, 08, 18	MMA-06XX-TH	
			0.18	02, 04, 08, 18	MMA-18XX-VG	
		0.25	02, 04, 08, 12	MMA-25XX-VG		
	HST-2: 300 G, 3 kG, 30 kG	Fiberglass epoxy	0.187	02, 04, 08	MNA-19XX-VG	
		Aluminum	0.18	04, 08	MMA-18XX-WL	
		Aluminum	0.18	02, 04, 08, 18	MMA-18XX-VH	
HST-2: 300 G, 3 kG, 30 kG	Aluminum	0.25	02, 04, 08, 12	MMA-25XX-VH		
		Fiberglass epoxy	0.187	02, 04, 08	MNA-19XX-VH	

Step 2: Within the table, choose the probe frequency range and field range.

Built-to-Order Probes
Axial probes for Model 460, 450, and 421 gaussmeters

Frequency range	Full-scale field ranges	Stem material	Stem diameter (in)	Stem lengths (in)	Probe part number	*
DC	HST-2: 300 G, 3 kG, 30 kG	Aluminum	0.08	02, 04, 08	MMA-08XX-UH	* Cable length can be changed. See below.
	HST-1: 300 G, 3 kG, 30 kG, 300 kG	Aluminum	0.25	04, 36	MMA-25XX-WL	
DC and 10 Hz to 400 Hz	HST-2: 300 G, 3 kG, 30 kG	Aluminum	0.06	02, 04, 08, 18	MMA-06XX-TH	
			0.18	02, 04, 08, 18	MMA-18XX-VG	
		0.25	02, 04, 08, 12	MMA-25XX-VG		
	HST-2: 300 G, 3 kG, 30 kG	Fiberglass epoxy	0.187	02, 04, 08	MNA-19XX-VG	
		Aluminum	0.18	04, 08	MMA-18XX-WL	
		Aluminum	0.18	02, 04, 08, 18	MMA-18XX-VH	
HST-2: 300 G, 3 kG, 30 kG	Aluminum	0.25	02, 04, 08, 12	MMA-25XX-VH		
		Fiberglass epoxy	0.187	02, 04, 08	MNA-19XX-VH	

Step 3: Choose your stem material and diameter/thickness.

Built-to-Order Probes
Axial probes for Model 460, 450, and 421 gaussmeters

Frequency range	Full-scale field ranges	Stem material	Stem diameter (in)	Stem lengths (in)	Probe part number	*
DC	HST-2: 300 G, 3 kG, 30 kG	Aluminum	0.08	02, 04, 08	MMA-08XX-UH	* Cable length can be changed. See below.
	HST-1: 300 G, 3 kG, 30 kG, 300 kG	Aluminum	0.25	04, 36	MMA-25XX-WL	
DC and 10 Hz to 400 Hz	HST-2: 300 G, 3 kG, 30 kG	Aluminum	0.06	02, 04, 08, 18	MMA-06XX-TH	
			0.18	02, 04, 08, 18	MMA-18XX-VG	
		0.25	02, 04, 08, 12	MMA-25XX-VG		
	HST-2: 300 G, 3 kG, 30 kG	Fiberglass epoxy	0.187	02, 04, 08	MNA-19XX-VG	
		Aluminum	0.18	04, 08	MMA-18XX-WL	
		Aluminum	0.18	02, 04, 08, 18	MMA-18XX-VH	
HST-2: 300 G, 3 kG, 30 kG	Aluminum	0.25	02, 04, 08, 12	MMA-25XX-VH		
		Fiberglass epoxy	0.187	02, 04, 08	MNA-19XX-VH	

Step 4: Specify stem length by filling in the "XX." This gives you the probe part number.

Built-to-Order Probes
Axial probes for Model 460, 450, and 421 gaussmeters

Frequency range	Full-scale field ranges	Stem material	Stem diameter (in)	Stem lengths (in)	Probe part number	*
DC	HST-2: 300 G, 3 kG, 30 kG	Aluminum	0.08	02, 04, 08	MMA-08XX-UH	* Cable length can be changed. See below.
	HST-1: 300 G, 3 kG, 30 kG, 300 kG	Aluminum	0.25	04, 36	MMA-25XX-WL	
DC and 10 Hz to 400 Hz	HST-2: 300 G, 3 kG, 30 kG	Aluminum	0.06	02, 04, 08, 18	MMA-06XX-TH	
			0.18	02, 04, 08, 18	MMA-18XX-VG	
		0.25	02, 04, 08, 12	MMA-25XX-VG		
	HST-2: 300 G, 3 kG, 30 kG	Fiberglass epoxy	0.187	02, 04, 08	MNA-19XX-VG	
		Aluminum	0.18	04, 08	MMA-18XX-WL	
		Aluminum	0.18	02, 04, 08, 18	MMA-18XX-VH	
HST-2: 300 G, 3 kG, 30 kG	Aluminum	0.25	02, 04, 08, 12	MMA-25XX-VH		
		Fiberglass epoxy	0.187	02, 04, 08	MNA-19XX-VH	

Step 5 (optional): By default, most probes come with a 2 m cable. However, other cable lengths are available. For 3 m, 6 m, 10 m, 20 m, and 30 m probe cable lengths, add -03, -06, -10, -20, or -30 to end of the probe part number.

Hall probes

Built-to-Order Probes

Axial probes for Model 475, 455, and 425 gaussmeters



Frequency range	Full-scale field ranges	Stem material	Stem diameter (in)	Stem lengths (in)	Probe part number	*
DC	HST-4: 35 G, 350 G, 3.5 kG, 35 kG	Aluminum	0.08	02, 04, 08	HMMA-08XX-UH	* Cable length can be changed. See below.
	HST-3: 35 G, 350 G, 3.5 kG, 35 kG, 350 kG	Aluminum	0.25	04, 36	HMMA-25XX-WL	
DC to 400 Hz	HST-4: 35 G, 350 G, 3.5 kG, 35 kG	Aluminum	0.06	02, 04, 08, 18	HMMA-06XX-TH	
			0.18	02, 04, 08, 18	HMMA-18XX-VF	
			0.25	02, 04, 08, 12	HMMA-25XX-VF	
	HST-3: 35 G, 350 G, 3.5 kG, 35 kG, 350 kG	Aluminum	0.18	04, 08	HMMA-18XX-WL	
DC to 800 Hz	HST-4: 35 G, 350 G, 3.5 kG, 35 kG	Fiberglass epoxy	0.187	02, 04, 08	HMNA-19XX-VF	
DC to 10 kHz	HSE: 3.5 G, 35 G, 350 G, 3.5 kG, 35 kG	Aluminum	0.18	02, 04, 08, 18	HMMA-18XX-VR	
			0.25	02, 04, 08, 12	HMMA-25XX-VR	
DC to 20 kHz	HSE: 3.5 G, 35 G, 350 G, 3.5 kG, 35 kG	Fiberglass epoxy	0.187	02, 04, 08	HMNA-19XX-VR	
DC to 50 kHz	HSE: 3.5 G, 35 G, 350 G, 3.5 kG, 35 kG	Fiberglass epoxy	0.25	18	HMNA-25XX-VR-HF	

Transverse probes for Model 475, 455, and 425 gaussmeters



Frequency range	Full-scale field ranges	Stem material	Stem thickness (in)	Stem lengths (in)	Probe part number	*
DC	HST-4: 35 G, 350 G, 3.5 kG, 35 kG	Brass	0.061	02, 04, 08	HMMTB-6JXX-VF	* Cable length can be changed. See below.
	HSE: 3.5 G, 35 G, 350 G, 3.5 kG, 35 kG	Brass	0.061	02, 04, 08	HMMTB-6JXX-VR	
DC to 400 Hz	HST-4: 35 G, 350 G, 3.5 kG, 35 kG	Aluminum	0.061	02, 04, 08, 12, 18	HMMT-6JXX-VF	
DC to 800 Hz	HSE: 3.5 G, 35 G, 350 G, 3.5 kG, 35 kG	Aluminum	0.061	02, 04, 08, 12, 18	HMMT-6JXX-VR	
			Fiberglass epoxy	0.045	02, 04	
		Flexible plastic tubing	0.02	03	HMFT-29XX-VH	
			0.025	03	HMFT-3EXX-VF	
DC to 20 kHz	HSE: 3.5 G, 35 G, 350 G, 3.5 kG, 35 kG	Fiberglass epoxy	0.045	02, 04	HMNT-4EXX-VR	
		Flexible plastic tubing	0.02	03	HMFT-29XX-VJ	
			0.025	03	HMFT-3EXX-VR	

04 Indicates probe characteristic and length that is offered as a stock probe. This item would not need to be "built-to-order." See page 31 for our stock probes.

***** By default, most probes have a 2 m long cable. Also available: 3 m, 6 m, 10 m, 20 m, and 30 m lengths. To specify a length other than default length, add -03, -06, -10, -20, or -30 to end of the probe part number.

For the specifications of each probe, please see the individual probe product spec sheets, starting on page 37.

Hall probes

Built-to-Order Probes

Axial probes for Model 460, 450, and 421 gaussmeters



Frequency range	Full-scale field ranges	Stem material	Stem diameter (in)	Stem lengths (in)	Probe part number	*
DC	HST-2: 300 G, 3 kG, 30 kG	Aluminum	0.08	02, 04, 08	MMA-08XX-UH	* Cable length can be changed. See below.
	HST-1: 300 G, 3 kG, 30 kG, 300 kG	Aluminum	0.25	04, 36	MMA-25XX-WL	
DC and 10 Hz to 400 Hz	HST-2: 300 G, 3 kG, 30 kG	Aluminum	0.06	02, 04, 08, 18	MMA-06XX-TH	
			0.18	02, 04, 08, 18	MMA-18XX-VG	
			0.25	02, 04, 08, 12	MMA-25XX-VG	
	HST-1: 300 G, 3 kG, 30 kG, 300 kG	Fiberglass epoxy	0.187	02, 04, 08	MNA-19XX-VG	
		Aluminum	0.18	04, 08	MMA-18XX-WL	
		Aluminum	0.18	02, 04, 08, 18	MMA-18XX-VH	
HSE-1: 30 G, 300 G, 3 kG, 30 kG	Aluminum	0.25	02, 04, 08, 12	MMA-25XX-VH		
		Fiberglass epoxy	0.187	02, 04, 08	MNA-19XX-VH	

Transverse probes for Model 460, 450, and 421 gaussmeters



Frequency range	Full-scale field ranges	Stem material	Stem thickness (in)	Stem lengths (in)	Probe part number	*
DC	HST-2: 300 G, 3 kG, 30 kG	Aluminum	0.061	02, 04, 08, 12, 18	MMT-6JXX-VG	* Cable length can be changed. See below.
		Brass	0.061	02, 04, 08	MMTB-6JXX-VG	
	HSE-1: 30 G, 300 G, 3 kG, 30 kG	Brass	0.061	02, 04, 08	MMTB-6JXX-VH	
DC and 10 Hz to 100 Hz	HSE-1: 30 G, 300 G, 3 kG, 30 kG	Aluminum	0.061	02, 04, 08, 12, 18	MMT-6JXX-VH	
DC and 10 Hz to 400 Hz	HST-2: 300 G, 3 kG, 30 kG	Fiberglass epoxy	0.045	02, 04	MNT-4EXX-VG	
		Flexible plastic tubing	0.02	03	MFT-29XX-VH	
			0.025	03	MFT-3EXX-VG	
	HSE-1: 30 G, 300 G, 3 kG, 30 kG	Fiberglass epoxy	0.045	02, 04	MNT-4EXX-VH	
		Flexible plastic tubing	0.02	03	MFT-29XX-VJ	
			0.025	03	MFT-3EXX-VH	

Transverse and axial probes for Model 410 gaussmeters



Orientation	Frequency range	Full-scale field ranges	Stem material	Stem lengths (in)	Probe part number
Axial	DC	200 G, 2 kG, 20 kG	Brass	02, 04	MSA-22XX-410
	DC to 10 kHz	200 G, 2 kG, 20 kG	Flexible plastic tubing	2.6	MSA-410
Transverse	DC	200 G, 2 kG, 20 kG	Brass	02, 04	MST-9PXX-410
	DC to 10 kHz	200 G, 2 kG, 20 kG	Flexible plastic tubing	2.6	MST-410

04 Indicates probe characteristic and length that is offered as a stock probe. This item would not need to be "built-to-order." See page 31 for our stock probes.

***** By default, most probes have a 2 m long cable. Also available: 3 m, 6 m, 10 m, 20 m, and 30 m lengths. To specify a length other than default length, add -03, -06, -10, -20, or -30 to end of the probe part number.

For the specifications of each probe, please see the individual probe product spec sheets, starting on page 37.

Hall probes

Specialized Probes—Built-to-Order

Tangential probes for Model 475, 455, 425, 460, 460, and 421 gaussmeters

Probes to measure tangential fields, which are fields parallel to and near a surface

Model	Orientation	Frequency range	Full-scale field ranges	Stem material	Stem thickness (in)	Stem length (in)	Probe part number	*
475, 455, 425	N/A	DC to 400 Hz	HSE: 3.5 G, 35 G, 350 G, 3.5 kG, 35 kG	Plastic	0.11	1.5	HMNTAN-DQ02-TH	Cable length can be changed. See below.
460, 450, 421	N/A	DC and 10 to 400 Hz	HSE-1: 30 G, 300 G, 3 kG, 30 kG	Plastic	0.11	1.5	MNTAN-DQ02-TH	

Cryogenic probes for Model 475, 455, 425, 460, 450, and 421 gaussmeters

Probes designed to withstand thermal contraction of probe materials while measuring at ultra-low temperatures

Model	Orientation	Frequency range	Full-scale field ranges	Stem material	Stem diameter (in)	Stem length (in)	Probe part number	*
475, 455, 425	Axial	DC	HST-3: 35 G, 350 G, 3.5 kG, 35 kG, 350 kG	Stainless steel	0.25	60	HMCA-2560-WN	Cryogenic probes have a standard 3 m cable; length can be changed. See below.
	Transverse	DC to 800 Hz	HST-3: 35 G, 350 G, 3.5 kG, 35 kG, 350 kG	Stainless steel	0.25	61	HMCT-3160-WN	
460, 450, 421	Axial	DC	HST-1: 300 G, 3 kG, 30 kG, 300 kG	Stainless steel	0.25	60	MCA-2560-WN	
	Transverse	DC and 10 Hz to 400 Hz	HST-1: 300 G, 3 kG, 30 kG, 300 kG	Stainless steel	0.25	61	MCT-3160-WN	

Multi-axis probes for Model 460 gaussmeter

Multi-sensor probes designed to measure two or three vectors of magnetic field simultaneously

Model	Orientation	Frequency range	Full-scale field ranges	Stem material	Stem diameter (in)	Approximate Stem lengths (in)	Probe part number	*
460	2-Axis	DC and 10 Hz to 400 Hz	HSE-1: 30 G, 300 G, 3 kG, 30 kG	Aluminum	0.18	02, 04, 08, 18, 36	MMY-18XX-UH	Cable length can be changed. See below.
	3-Axis	DC and 10 Hz to 400 Hz	HSE-1: 30 G, 300 G, 3 kG, 30 kG	Aluminum	0.25	02, 04, 08, 12, 18, 36, 60	MMZ-25XX-UH	

04 Indicates probe characteristic and length that is offered as a stock probe. This item would not need to be "built-to-order." See page 31 for our stock probes.

* By default, most probes have a 2 m long cable. Also available: 3 m, 6 m, 10 m, 20 m, and 30 m lengths. To specify a length other than default length, add -03, -06, -10, -20, or -30 to end of the probe part number.

For the specifications of each probe, please see the individual probe product spec sheets, starting on page 37.

Hall probes

Specifications

Axial probes

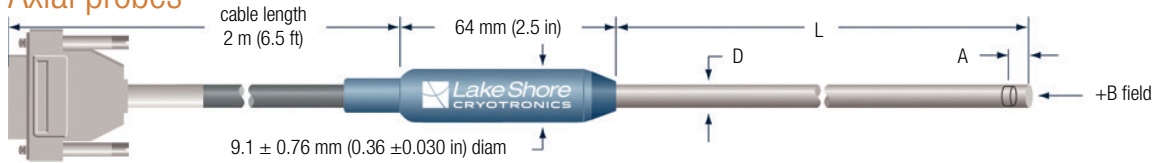

Operating temperature range: 0 °C to +75 °C

RoHS	L mm (in)	D mm (in)	A mm (in)	Active area mm (in)	Stem material	Frequency range	Usable full scale ranges	Corrected accuracy (% rdg at 25 °C)	Temp coefficient (max) zero	Temp coefficient (max) of sensitivity	Contains temp sensor	
for Models 475, 455, and 425												
HMMA-0602-TH	No	50.8 ± 3.2 (2 ± 0.125)	1.52 dia ± 0.03/-0.08 (0.060 dia ± 0.001/-0.003)	0.13 ± 0.08 (0.005 ± 0.003)	Approx 0.51 dia (0.020 dia)	Aluminum	DC to 400 Hz	HST-4 35 G, 350 G, 3.5 kG, 35 kG	±0.25% to 10 kG	±0.13 G/°C	±0.01%/°C	No
HMMA-0604-TH	No	101.6 ± 3.2 (4 ± 0.125)										
HMMA-0608-TH	No	203.2 ± 3.2 (8 ± 0.125)	2.03 dia ± 0.13 (0.080 dia ± 0.005)	0.25 ± 0.13 (0.010 ± 0.005)		DC		±0.25% to 20 kG				
HMMA-0618-TH	No	457 ± 3.2 (18 ± 0.25)										
HMMA-0802-UH	No	50.8 ± 3.2 (2 ± 0.125)	4.75 dia ± 0.13 (0.187 dia ± 0.005)	0.13 ± 0.08 (0.005 ± 0.003)		Fiberglass epoxy	DC to 20 kHz					
HMMA-0804-UH	No	101.6 ± 3.2 (4 ± 0.125)										
HMMA-0808-UH	No	203.2 ± 3.2 (8 ± 0.125)	4.57 dia ± 0.05/-0.10 (0.180 dia ± 0.002/-0.004)	0.38 ± 0.13 (0.015 ± 0.005)		Aluminum	DC to 10 kHz	HSE 3.5 G, 35 G, 350 G, 3.5 kG, 35 kG	±0.20% to 30 kG and ±0.25% 30 to 35 kG	±0.09 G/°C	455/475: ±0.015%/°C 425: -0.04%/°C	
HMMA-1902-VR	No	50.8 ± 3.2 (2 ± 0.125)										
HMMA-1904-VR	Yes	101.6 ± 3.2 (4 ± 0.125)	6.35 dia ± 0.15 (0.25 dia ± 0.006)	0.64 ± 0.13 (0.025 ± 0.005)		Fiberglass epoxy	DC to 50 kHz					Yes
HMMA-1908-VR	No	203.2 ± 3.2 (8 ± 0.125)										
HMMA-1802-VR	No	50.8 ± 1.6 (2 ± 0.063)	4.75 dia ± 0.13 (0.187 dia ± 0.005)	0.13 ± 0.08 (0.005 ± 0.003)	Approx 0.76 dia (0.030 dia)	Fiberglass epoxy	DC to 800 Hz					
HMMA-1804-VR	No	101.6 ± 3.2 (4 ± 0.125)										
HMMA-1808-VR	No	203.2 ± 3.2 (8 ± 0.125)	4.57 dia ± 0.05/-0.10 (0.180 dia ± 0.002/-0.004)	0.38 ± 0.13 (0.015 ± 0.005)		Aluminum	DC to 400 Hz	HST-4 35 G, 350 G, 3.5 kG, 35 kG	±0.10% to 30 kG and ±0.15% 30 to 35 kG	±0.13 G/°C	-0.005%/°C	
HMMA-1818-VR	No	457 ± 6.4 (18 ± 0.25)										
HMMA-1836-VR	No	914 ± 6.4 (36 ± 0.25)	6.35 dia ± 0.15 (0.25 dia ± 0.006)	0.64 ± 0.13 (0.025 ± 0.005)		Fiberglass epoxy	DC to 800 Hz					
HMMA-2502-VR	No	50.8 ± 1.6 (2 ± 0.063)										
HMMA-2504-VR	Yes	101.6 ± 3.2 (4 ± 0.125)	4.57 dia ± 0.05/-0.10 (0.180 dia ± 0.002/-0.004)	0.38 ± 0.13 (0.015 ± 0.005)		Aluminum	DC to 400 Hz	HST-4 35 G, 350 G, 3.5 kG, 35 kG	±0.10% to 30 kG and ±0.15% 30 to 35 kG	±0.13 G/°C	-0.005%/°C	
HMMA-2508-VR	No	203.2 ± 3.2 (8 ± 0.125)										
HMMA-2512-VR	No	305 ± 6.4 (12 ± 0.25)	6.35 dia ± 0.15 (0.25 dia ± 0.006)	0.64 ± 0.13 (0.025 ± 0.005)		Fiberglass epoxy	DC to 800 Hz					
HMNA-2518-VR-HF	No	457 ± 12.7 (18 ± 0.5)										
HMNA-1902-VF	No	50.8 ± 3.2 (2 ± 0.125)	4.75 dia ± 0.13 (0.187 dia ± 0.005)	0.13 ± 0.08 (0.005 ± 0.003)	Approx 0.76 dia (0.030 dia)	Fiberglass epoxy	DC to 800 Hz					
HMNA-1904-VF	Yes	101.6 ± 3.2 (4 ± 0.125)										
HMNA-1908-VF	No	203.2 ± 3.2 (8 ± 0.125)	4.57 dia ± 0.05/-0.10 (0.180 dia ± 0.002/-0.004)	0.38 ± 0.13 (0.015 ± 0.005)		Aluminum	DC to 400 Hz	HST-4 35 G, 350 G, 3.5 kG, 35 kG	±0.10% to 30 kG and ±0.15% 30 to 35 kG	±0.13 G/°C	-0.005%/°C	
HMMA-1802-VF	No	50.8 ± 1.6 (2 ± 0.063)										
HMMA-1804-VF	No	101.6 ± 3.2 (4 ± 0.125)	6.35 dia ± 0.15 (0.25 dia ± 0.006)	0.64 ± 0.13 (0.025 ± 0.005)		Fiberglass epoxy	DC to 800 Hz					
HMMA-1808-VF	No	203.2 ± 3.2 (8 ± 0.125)										
HMMA-1818-VF	No	457 ± 6.4 (18 ± 0.25)	4.57 dia ± 0.05/-0.10 (0.180 dia ± 0.002/-0.004)	0.38 ± 0.13 (0.015 ± 0.005)		Aluminum	DC to 400 Hz	HST-4 35 G, 350 G, 3.5 kG, 35 kG	±0.10% to 30 kG and ±0.15% 30 to 35 kG	±0.13 G/°C	-0.005%/°C	
HMMA-1836-VF	No	914 ± 6.4 (36 ± 0.25)										
HMMA-2502-VF	No	50.8 ± 1.6 (2 ± 0.063)	6.35 dia ± 0.15 (0.25 dia ± 0.006)	0.64 ± 0.13 (0.025 ± 0.005)		Fiberglass epoxy	DC to 800 Hz					
HMMA-2504-VF	Yes	101.6 ± 3.2 (4 ± 0.125)										
HMMA-2508-VF	No	203.2 ± 3.2 (8 ± 0.125)	4.57 dia ± 0.05/-0.10 (0.180 dia ± 0.002/-0.004)	0.38 ± 0.13 (0.015 ± 0.005)		Aluminum	DC to 400 Hz	HST-4 35 G, 350 G, 3.5 kG, 35 kG	±0.10% to 30 kG and ±0.15% 30 to 35 kG	±0.13 G/°C	-0.005%/°C	
HMMA-2512-VF	No	305 ± 6.4 (12 ± 0.25)										
HMMA-1804-WL	No	101.6 ± 3.2 (4 ± 0.125)	6.35 dia ± 0.15 (0.25 dia ± 0.006)	0.64 ± 0.13 (0.025 ± 0.005)		Fiberglass epoxy	DC to 800 Hz					
HMMA-1808-WL	No	203.2 ± 3.2 (8 ± 0.125)										
HMMA-2504-WL	No	101.6 ± 3.2 (4 ± 0.125)	4.57 dia ± 0.05/-0.10 (0.180 dia ± 0.002/-0.004)	0.38 ± 0.13 (0.015 ± 0.005)		Aluminum	DC to 400 Hz	HST-4 35 G, 350 G, 3.5 kG, 35 kG	±0.10% to 30 kG and ±0.15% 30 to 35 kG	±0.13 G/°C	-0.005%/°C	
HMMA-2536-WL	No	914 ± 6.4 (36 ± 0.25)										
HMMA-2536-WL	No	914 ± 6.4 (36 ± 0.25)	6.35 dia ± 0.15 (0.25 dia ± 0.006)	0.64 ± 0.13 (0.025 ± 0.005)		Fiberglass epoxy	DC to 800 Hz					
HMMA-2536-WL	No	914 ± 6.4 (36 ± 0.25)										

Note: 15 in flexible probes are no longer available. Please contact your local sales representative to discuss alternatives if you require a similar product for your application.

Hall probes

Specifications

Axial probes

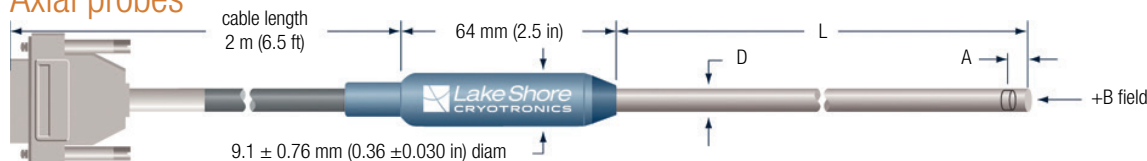

	L mm (in)	D mm (in)	A mm (in)	Active area mm (in)	Stem material	Frequency range	Usable full scale ranges	Corrected accuracy (% rdg at 25 °C)	Operating temp range (°C)	Temp coefficient (max) zero	Temp coefficient (max) of sensitivity	Contains temp sensor
for Models 460, 450, and 421												
MMA-0602-TH	50.8 ±3.2 (2 ±0.125)	1.52 dia ±0.03/-0.08 (0.060 dia ±0.001/-0.003)	0.13 ±0.08 (0.005 ±0.003)	Approx 0.51 dia (0.020 dia)	Aluminum	DC and 10 Hz to 400 Hz	HST-2 300 G, 3 kG, 30 kG	±0.25% to 10 kG	0 °C to +75 °C	±0.13 G/°C	±0.01%/°C	No
MMA-0604-TH	101.6 ±3.2 (4 ±0.125)											
MMA-0608-TH	203.2 ±3.2 (8 ±0.125)											
MMA-0618-TH	457 ±6.4 (18 ±0.25)	2.03 dia ±0.13 (0.080 dia ±0.005)	0.25 ±0.13 (0.010 ±0.005)			DC		±0.25% to 20 kG				
MMA-0802-UH	50.8 ±3.2 (2 ±0.125)											
MMA-0804-UH	101.6 ±3.2 (4 ±0.125)											
MMA-0808-UH	203.2 ±3.2 (8 ±0.125)	4.75 dia ±0.13 (0.187 dia ±0.005)	0.13 ±0.08 (0.005 ±0.003)		Fiberglass epoxy							
MNA-1902-VH	50.8 ±3.2 (2 ±0.125)											
MNA-1904-VH	101.6 ±3.2 (4 ±0.125)											
MNA-1908-VH	203.2 ±3.2 (8 ±0.125)	4.57 dia ±0.05/-0.10 (0.180 dia ±0.002/-0.004)	0.13 ±0.08 (0.005 ±0.003)	Approx 0.76 dia (0.030 dia)	Fiberglass epoxy		HSE-1 30 G, 300 G, 3 kG, 30 kG	±0.25% to 30 kG	0 °C to +75 °C	±0.09 G/°C	450/460: ±0.015%/°C 421: -0.04%/°C	Yes
MMA-1802-VH	50.8 ±1.6 (2 ±0.063)											
MMA-1804-VH	101.6 ±3.2 (4 ±0.125)											
MMA-1808-VH	203.2 ±3.2 (8 ±0.125)	6.35 dia ±0.15 (0.25 dia ±0.006)	0.38 ±0.13 (0.015 ±0.005)		Aluminum							
MMA-1818-VH	457 ±6.4 (18 ±0.25)											
MMA-2502-VH	50.8 ±1.6 (2 ±0.063)											
MMA-2504-VH	101.6 ±3.2 (4 ±0.125)	6.35 dia ±0.15 (0.25 dia ±0.006)	0.38 ±0.13 (0.015 ±0.005)		Aluminum							
MMA-2508-VH	203.2 ±3.2 (8 ±0.125)											
MMA-2512-VH	305 ±6.4 (12 ±0.25)											
MNA-1902-VG	50.8 ±3.2 (2 ±0.125)	4.75 dia ±0.13 (0.187 dia ±0.005)	0.13 ±0.08 (0.005 ±0.003)	Approx 0.76 dia (0.030 dia)	Fiberglass epoxy	DC and 10 Hz to 400 Hz						
MNA-1904-VG	101.6 ±3.2 (4 ±0.125)											
MNA-1908-VG	203.2 ±3.2 (8 ±0.125)											
MMA-1802-VG	50.8 ±1.6 (2 ±0.063)	4.57 dia ±0.05/-0.10 (0.180 dia ±0.002/-0.004)	0.38 ±0.13 (0.015 ±0.005)		Aluminum		HST-2 300 G, 3 kG, 30 kG	±0.15% to 30 kG		±0.13 G/°C	-0.005%/°C	No
MMA-1804-VG	101.6 ±3.2 (4 ±0.125)											
MMA-1808-VG	203.2 ±3.2 (8 ±0.125)											
MMA-1818-VG	457 ±6.4 (18 ±0.25)	6.35 dia ±0.15 (0.25 dia ±0.006)	0.38 ±0.13 (0.015 ±0.005)		Aluminum							
MMA-2502-VG	50.8 ±1.6 (2 ±0.063)											
MMA-2504-VG	101.6 ±3.2 (4 ±0.125)											
MMA-2508-VG	203.2 ±3.2 (8 ±0.125)	4.57 dia ±0.05/-0.10 (0.180 dia ±0.002/-0.004)	0.38 ±0.13 (0.015 ±0.005)		Aluminum		HST-1 300 G, 3 kG, 30 kG, 300 kG	±1% to 100 kG				
MMA-2512-VG	305 ±6.4 (12 ±0.25)											
MMA-1804-WL	101.6 ±3.2 (4 ±0.125)											
MMA-1808-WL	203.2 ±3.2 (8 ±0.125)	6.35 dia ±0.15 (0.25 dia ±0.006)	0.38 ±0.13 (0.015 ±0.005)		Aluminum	DC						
MMA-2504-WL	101.6 ±3.2 (4 ±0.125)											
MMA-2536-WL	914 ±6.4 (36 ±0.25)											

Note: 15 in flexible probes are no longer available. Please contact your local sales representative to discuss alternatives if you require a similar product for your application.

Hall probes

Specifications

Transverse probes

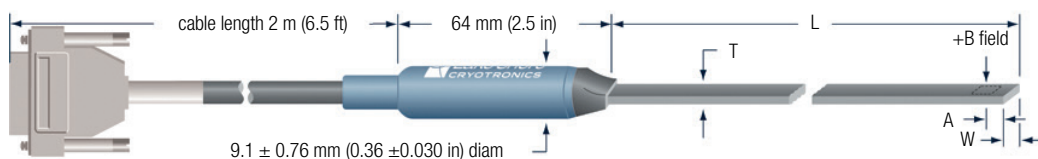

Operating temperature range: 0 °C to +75 °C

RoHS	L mm (in)	T mm (in)	W mm (in)	A mm (in)	Active area mm (in)	Stem material	Frequency range	Usable full scale ranges	Corrected accuracy (% rdg at 25 °C)	Temp coefficient (max) zero	Temp coefficient (max) of sensitivity	Contains temp sensor
for Models 475, 455, and 425												
No	50.8 ± 3.2 (2 ± 0.125)	1.55 (0.061) max	4.57 ± 0.13 (0.180 ± 0.005)	3.81 ± 1.27 (0.150 ± 0.050)	Approx 1.02 dia (0.040 dia)	Aluminum	DC to 800 Hz	HSE 3.5 G, 35 G, 350 G, 3.5 kG, 35 kG	±0.20% to 30 kG; ±0.25% 30 to 35 kG	±0.09 G/°C	455/475: ±0.015%/°C 425: -0.04%/°C	Yes
Yes	101.6 ± 3.2 (4 ± 0.125)											
No	203.2 ± 3.2 (8 ± 0.125)											
No	305 ± 6.4 (12 ± 0.25)											
No	457 ± 6.4 (18 ± 0.25)											
No	50.8 ± 3.2 (2 ± 0.125)	1.14 (0.045) max	3.81 ± 0.13 (0.150 ± 0.005)	3.81 ± 1.27 (0.150 ± 0.050)	Fiberglass epoxy	DC to 20 kHz						
Yes	101.6 ± 3.2 (4 ± 0.125)											
No	50.8 ± 3.2 (2 ± 0.125)											
Yes	101.6 ± 3.2 (4 ± 0.125)											
No	203.2 ± 3.2 (8 ± 0.125)											
No	305 ± 6.4 (12 ± 0.25)											
No	457 ± 6.4 (18 ± 0.25)											
No	50.8 ± 3.2 (2 ± 0.125)	1.14 (0.045) max	3.81 ± 0.13 (0.150 ± 0.005)	3.81 ± 1.27 (0.150 ± 0.050)	Fiberglass epoxy	DC to 800 Hz			±0.10% to 30 kG; ±0.15% 30 to 35 kG	±0.13 G/°C	-0.005%/°C	
Yes	101.6 ± 3.2 (4 ± 0.125)											
for Models 460, 450, and 421												
No	50.8 ± 3.2 (2 ± 0.125)	1.55 (0.061) max	4.57 ± 0.13 (0.180 ± 0.005)	3.81 ± 1.27 (0.150 ± 0.050)	Approx 1.02 dia (0.040 dia)	Aluminum	DC and 10 Hz to 100 Hz	HSE-1 30 G, 300 G, 3 kG, 30 kG	±0.25% to 30 kG	±0.09 G/°C	450/460: ±0.015%/°C 421: -0.04%/°C	Yes
	101.6 ± 3.2 (4 ± 0.125)											
	203.2 ± 3.2 (8 ± 0.125)											
	305 ± 6.4 (12 ± 0.25)											
	457 ± 6.4 (18 ± 0.25)											
	50.8 ± 3.2 (2 ± 0.125)	1.14 (0.045) max	3.81 ± 0.13 (0.150 ± 0.005)	3.81 ± 1.27 (0.150 ± 0.050)	Fiberglass epoxy	DC and 10 Hz to 400 Hz						
	101.6 ± 3.2 (4 ± 0.125)											
	50.8 ± 3.2 (2 ± 0.125)	1.55 (0.061) max	4.57 ± 0.13 (0.180 ± 0.005)	3.81 ± 1.27 (0.150 ± 0.050)	Approx 1.02 dia (0.040 dia)	Aluminum	DC	HST-2 300 G, 3 kG, 30 kG	±0.15% to 30 kG	±0.13 G/°C	-0.005%/°C	No
	101.6 ± 3.2 (4 ± 0.125)											
	203.2 ± 3.2 (8 ± 0.125)											
	305 ± 6.4 (12 ± 0.25)											
	457 ± 6.4 (18 ± 0.25)											
50.8 ± 3.2 (2 ± 0.125)	1.14 (0.045) max	3.81 ± 0.13 (0.150 ± 0.005)	3.81 ± 1.27 (0.150 ± 0.050)	Approx 1.02 dia (0.040 dia)	Fiberglass epoxy	DC and 10 Hz to 400 Hz						
101.6 ± 3.2 (4 ± 0.125)												

Hall probes

Specifications

Brass stem transverse probes (short)

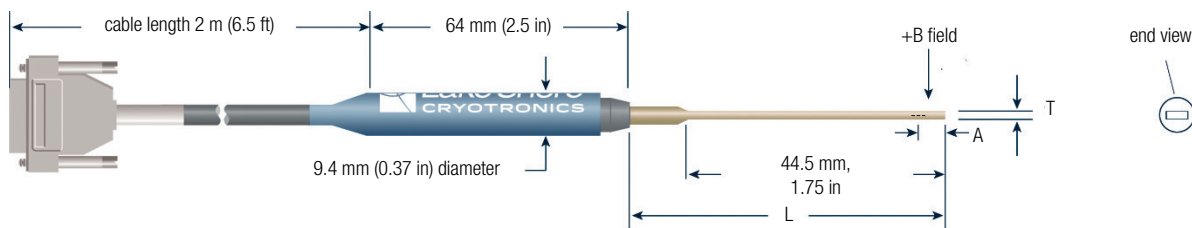

Operating temperature range: 0 °C to +75 °C

RoHS	L mm (in)	T mm (in)	Width mm (in)	A mm (in)	Active area mm (in)	Stem material	Frequency range	Usable full scale ranges	Corrected accuracy (% rdg at 25 °C)	Temp coefficient (max) zero	Temp coefficient (max) of sensitivity	Contains temp sensor	
for Models 475, 455, and 425													
HMMTB-6J02-VR	No	50.8 ±3.2 (2 ±0.125)	1.78 (0.070) max	5.59 (0.22)	3.81 ±1.27 (0.150 ±0.050)	Approx 1.02 dia (0.040 dia)	Brass	DC	HSE 3.5 G, 35 G, 350 G, 3.5 kG, 35 kG	±0.20% to 30 kG and ±0.25% 30 to 35 kG	±0.09 G/°C	455/475: ±0.015%/°C 425: -0.04%/°C	Yes
HMMTB-6J02-VF									HST-4 35 G, 350 G, 3.5 kG, 35 kG	±0.10% to 30 kG and ±0.15% 30 to 35 kG	±0.13 G/°C	-0.005%/°C	
for Models 460, 450, and 421													
MMTB-6J02-VH	No	50.8 ±3.2 (2 ±0.125)	1.78 (0.070) max	5.59 (0.22)	3.81 ±1.27 (0.150 ±0.050)	Approx 1.02 dia (0.040 dia)	Brass	DC	HSE-1 30 G, 300 G, 3 kG, 30 kG	±0.25% to 30 kG	±0.09 G/°C	450/460: ±0.015%/°C 421: -0.04%/°C	Yes
MMTB-6J02-VG									HST-2 300 G, 3 kG, 30 kG	±0.15% to 30 kG	±0.13 G/°C	-0.005%/°C	

Brass stem transverse probes (long)

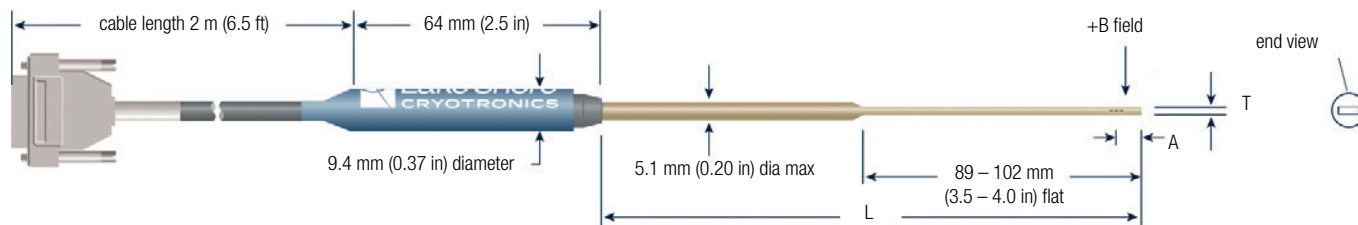

Operating temperature range: 0 °C to +75 °C

RoHS	L mm (in)	T mm (in)	Width mm (in)	A mm (in)	Active area mm (in)	Stem material	Frequency range	Usable full scale ranges	Corrected accuracy (% rdg at 25 °C)	Temp coefficient (max) zero	Temp coefficient (max) of sensitivity	Contains temp sensor	
for Models 475, 455, and 425													
HMMTB-6J04-VR	No	101.6 ±3.2 (4 ±0.125)	1.78 (0.070) max	5.58 (0.22)	3.81 ±1.27 (0.150 ±0.050)	Approx 1.02 dia (0.040 dia)	Brass	DC	HSE 3.5 G, 35 G, 350 G, 3.5 kG, 35 kG	±0.20% to 30 kG and ±0.25% 30 to 35 kG	±0.09 G/°C	455/475: ±0.015%/°C 425: -0.04%/°C	Yes
HMMTB-6J08-VR		203.2 ±3.2 (8 ±0.125)											
HMMTB-6J04-VF		101.6 ±3.2 (4 ±0.125)											
HMMTB-6J08-VF		203.2 ±3.2 (8 ±0.125)											
for Models 460, 450, and 421													
MMTB-6J04-VH	No	101.6 ±3.2 (4 ±0.125)	1.78 (0.070) max	5.58 (0.22)	3.81 ±1.27 (0.150 ±0.050)	Approx 1.02 dia (0.040 dia)	Brass	DC	HSE-1 30 G, 300 G, 3 kG, 30 kG	±0.25% to 30 kG	±0.09 G/°C	450/460: ±0.015%/°C 421: -0.04%/°C	Yes
MMTB-6J08-VH		203.2 ±3.2 (8 ±0.125)											
MMTB-6J04-VG		101.6 ±3.2 (4 ±0.125)											
MMTB-6J08-VG		203.2 ±3.2 (8 ±0.125)											
									HST-2 300 G, 3 kG, 30 kG	±0.15% to 30 kG	±0.13 G/°C	-0.005%/°C	No

Hall probes

Specifications

Flexible transverse probes

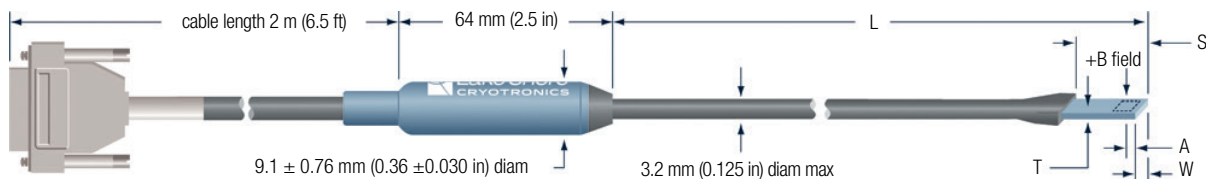

Operating temperature range: 0 °C to +75 °C

RoHS	L mm (in)	W mm (in)	T mm (in)	A mm (in)	S mm (in)	Active area mm (in)	Stem material	Frequency range	Usable full scale ranges	Corrected accuracy (% rdg at 25 °C)	Temp coefficient (max) zero	Temp coefficient (max) of sensitivity	Contains temp sensor	
for Models 475, 455, and 425														
HMFT-3E03-VR	No	76.2 +12.7/-3.18 (3 +0.5/-0.125)	3.42 (0.135) max	0.64 (0.025) max	3.18 ±0.13 (0.125 ±0.005)	9.52 (0.375)	Approx 1.02 dia (0.040 dia)	Flexible plastic tubing	DC to 20 kHz	HSE 3.5 G, 35 G, 350 G, 3.5 kG, 35 kG	±0.20% to 30 kG; ±0.25% 30 to 35 kG	±0.09 G/°C	±0.015%/°C	Yes
DC to 800 Hz									HST-4 35 G, 350 G, 3.5 kG, 35 kG	±0.10% to 30 kG; ±0.15% 30 to 35 kG	±0.13 G/°C	-0.005%/°C		
DC to 20 kHz									HSE 3.5 G, 35 G, 350 G, 3.5 kG, 35 kG	±0.50% to 35 kG	±0.09 G/°C	±0.015%/°C		
DC to 800 Hz									HST-4 35 G, 350 G, 3.5 kG, 35 kG	±0.25% to 35 kG	±0.13 G/°C	-0.005%/°C		
for Models 460, 450, and 421														
MFT-3E03-VH	No	76.2 +12.7/-3.18 (3 +0.5/-0.125)	3.42 (0.135) max	0.64 (0.025) max	3.18 ±0.13 (0.125 ±0.005)	9.52 (0.375)	Approx 1.02 dia (0.040 dia)	Flexible plastic tubing	DC and 10 Hz to 400 Hz	HSE-1 30 G, 300 G, 3 kG, 30 kG	±0.25% to 30 kG	±0.09 G/°C	450/460: ±0.015%/°C 421: -0.04%/°C	Yes
MFT-3E03-VG										HST-2 300 G, 3 kG, 30 kG	±0.15% to 30 kG	±0.13 G/°C	-0.005%/°C	No
MFT-2903-VJ										HSE-1 30 G, 300 G, 3 kG, 30 kG	±0.50% to 30 kG	±0.09 G/°C	450/460: ±0.015%/°C 421: -0.04%/°C	Yes
MFT-2903-VH										HST-2 300 G, 3 kG, 30 kG	±0.25% to 30 kG	±0.13 G/°C	-0.005%/°C	No

Note: 15 in flexible probes are no longer available. Please contact your local sales representative to discuss alternatives if you require a similar product for your application.

Hall probes

Specifications

Tangential probes

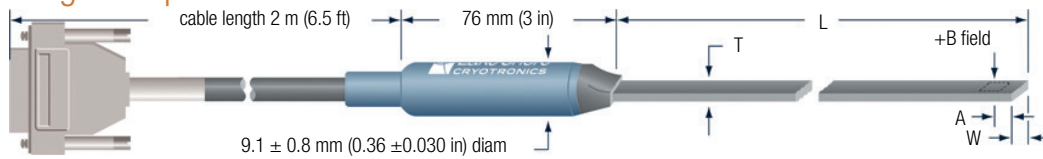

RoHS	L mm (in)	T mm (in)	W mm (in)	A mm (in)	Active area mm (in)	Stem material	Frequency range	Usable full scale ranges	Corrected accuracy (% rdg at 25 °C)	Operating temp range	Temp coefficient (max) zero	Temp coefficient (max) of sensitivity	Contains temp sensor	
for Models 475, 455, and 425														
HMNTAN-DQ02-TH	No	38.1 ±1.52 (1.5 ±0.060)	2.8 (0.11) max	6.6 (0.26) max	0.76 ±0.18 (0.030 ±0.005)	Approx 0.51 dia (0.020 dia)	Plastic	DC to 400 Hz	HSE 3.5 G, 35 G, 350 G, 3.5 kG, 35 kG	0.25% to 20 kG	0 °C to +75 °C	±0.1 G/°C	455/475: ±0.02%/°C 425: -0.05%/°C	Yes
for Models 460, 450, and 421														
MNTAN-DQ02-TH	No	38.1 ±1.52 (1.5 ±0.060)	2.8 (0.11) max	6.6 (0.26) max	0.76 ±0.18 (0.030 ±0.005)	Approx 0.51 dia (0.020 dia)	Plastic	DC and 10 Hz to 400 Hz	HSE-1 30 G, 300 G, 3 kG, 30 kG	0.25% to 20 kG	0 °C to +75 °C	±0.1 G/°C	-0.05%/°C	No

2-axis probes

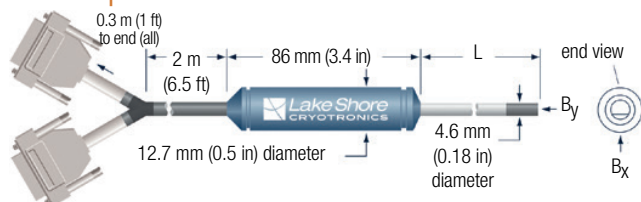

	L mm (in)	Stem material	Frequency range	Usable full scale ranges	Corrected accuracy (% rdg at 25 °C)	Operating temp range	Temp coefficient (max) zero	Temp coefficient (max) of sensitivity	Contains temp sensor
for Model 460 ONLY									
MMY-1802-UH	50.8 ±3.2 (2 ±0.125)	Aluminum	DC and 10 Hz to 400 Hz	HSE-1 30 G, 300 G, 3 kG, 30 kG	0.25% to 20 kG; 0.5% from 20 kG to 30 kG	10 °C to 40 °C	±0.09 G/°C	±0.015%/°C	Yes
MMY-1808-UH	203.2 ±3.2 (8 ±0.125)								
MMY-1818-UH	457 ±6.4 (18 ±0.25)								
MMY-1836-UH	914 ±6.4 (36 ±0.25)								

3-axis probes

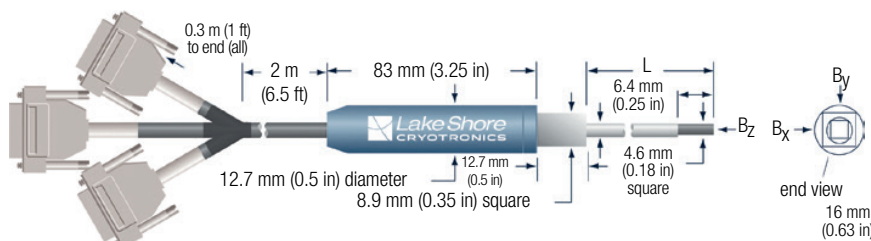

	L mm (in)	Stem material	Frequency range	Usable full scale ranges	Corrected accuracy (% rdg at 25 °C)	Operating temp range	Temp coefficient (max) zero	Temp coefficient (max) of sensitivity	Contains temp sensor
for Model 460 ONLY									
MMZ-2502-UH	54 ±3.2 (2.125 ±0.125)	Aluminum	DC and 10 Hz to 400 Hz	HSE-1 30 G, 300 G, 3 kG, 30 kG	0.25% to 20 kG; 0.5% from 20 kG to 30 kG	10 °C to 40 °C	±0.09 G/°C	±0.015%/°C	Yes
MMZ-2504-UH	104.8 ±3.2 (4.125 ±0.125)								
MMZ-2508-UH	206.4 ±3.2 (8.125 ±0.125)								
MMZ-2512-UH	308 ±3.2 (12.125 ±0.125)								
MMZ-2518-UH	460 ±6.4 (18.125 ±0.25)								
MMZ-2536-UH	918 ±6.4 (36.125 ±0.25)								
MMZ-2560-UH	1534 ±6.4 (60.375 ±0.5)								

NOTE: The sensors at the ends of the multi-axis probes are quite fragile and susceptible to damage. Lake Shore offers an assortment of brass covers for probe protection during use with DC fields. For more information, contact Lake Shore.

Hall probes

Specifications

Axial probes for cryogenic applications

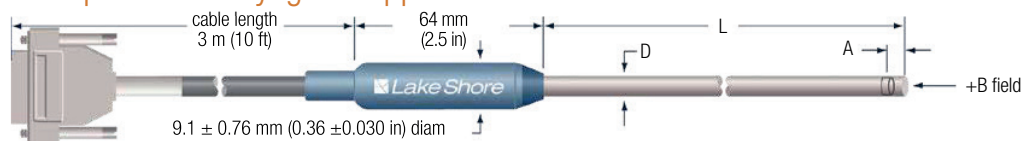

RoHS	L mm (in)	D mm (in)	A mm (in)	Active area mm (in)	Stem material	Frequency range	Usable full scale ranges	Corrected accuracy (% rdg at 25 °C)	Operating temp range	Temp coefficient (max) zero	Temp error (approx) calibration	Contains temp sensor	
for Models 475, 455, and 425											300 K	ref	
HMCA-2560-WN	No	1524 ±12.7 (60 ±0.50)	6.35 dia ±0.15 (0.25 dia ±0.006)	0.64 ±0.13 (0.025 ±0.005)	Approx 0.76 dia (0.030 dia)	Stainless steel	DC	HST-3 35 G, 350 G, 3.5 kG, 35 kG, 350 kG	±2% to 100 kG	1.5 K to 350 K	±0.13 G/°C	No	
for Models 460, 450, and 421											200 K	+0.05%	
MCA-2560-WN	No	1524 ±12.7 (60 ±0.50)	6.35 dia ±0.15 (0.25 dia ±0.006)	0.64 ±0.13 (0.025 ±0.005)	Approx 0.76 dia (0.030 dia)	Stainless steel	DC	HST-1 300 G, 3 kG, 30 kG, 300 kG	±2% to 100 kG	1.5 K to 350 K	±0.13 G/°C	No	
											100 K	-0.04%	
											80 K	-0.09%	
											20 K	-0.40%	
											4 K	-0.70%	
											1.5 K	-1.05%	

Transverse probes for cryogenic applications



RoHS	L mm (in)	D mm (in)	A mm (in)	Active area mm (in)	Stem material	Frequency range	Usable full scale ranges	Corrected accuracy (% rdg at 25 °C)	Operating temp range	Temp coefficient (max) zero	Temp error (approx) calibration	Contains temp sensor	
for Models 475, 455, and 425											300 K	ref	
HMCT-3160-WN	No	1549 ±25.4 (61 ±1)	6.35 dia ±0.25 (0.25 dia ±0.010)	5.33 ±1.27 (0.210 ±0.050)	Approx 1 dia (0.040 dia)	Stainless steel	DC to 800 Hz	HST-3 35 G, 350 G, 3.5 kG, 35 kG, 350 kG	±2% to 100 kG	1.5 K to 350 K	±0.13 G/°C	No	
for Models 460, 450, and 421											200 K	+0.05%	
MCT-3160-WN	No	1549 ±25.4 (61 ±1)	6.35 dia ±0.25 (0.25 dia ±0.010)	5.33 ±1.27 (0.210 ±0.050)	Approx 1 dia (0.040 dia)	Stainless steel	DC and 10 Hz to 400 Hz	HST-1 300 G, 3 kG, 30 kG, 300 kG	±2% to 100 kG	1.5 K to 350 K	±0.13 G/°C	No	
											100 K	-0.04%	
											80 K	-0.09%	
											20 K	-0.40%	
											4 K	-0.70%	
											1.5 K	-1.05%	

Hall probes

Specifications

Transverse probes for Model 410 gaussmeter

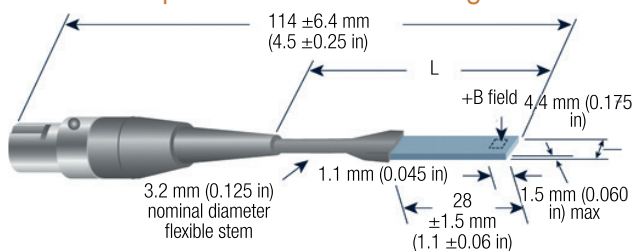

	L mm (in)	Active area mm (in)	Stem material	Frequency range	Usable full scale ranges	Accuracy (% rdg at 25 °C)	Operating temp range	Temp coefficient (max) zero	Temp coefficient (max) calibration	Contains temp sensor
MST-410	66 ± 6.4 (2.6 ± 0.25)	0.13 x 0.13 (0.005 x 0.005)	Flexible plastic tubing	DC to 10 kHz	200 G, 2 kG, 20 kG	2%	-10 °C to +75 °C	0.1 G/°C	-0.06%/°C	No

Brass stem transverse probes for Model 410 gaussmeter

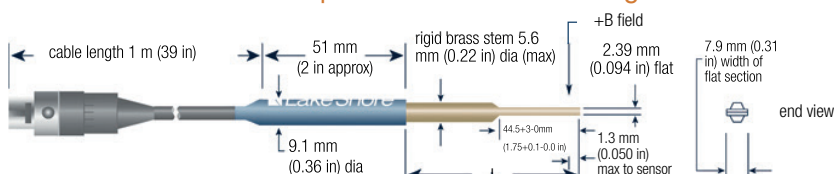

	L mm (in)	Active area mm (in)	Stem material	Frequency range	Usable full scale ranges	Accuracy (% rdg at 25 °C)	Operating temp range	Temp coefficient (max) zero	Temp coefficient (max) calibration	Contains temp sensor
MST-9P02-410	50.8 ± 3.2 (2 ± 0.125)	0.13 x 0.13 (0.005 x 0.005)	Brass	DC	200 G, 2 kG, 20 kG	2%	-10 °C to +75 °C	0.1 G/°C	-0.06%/°C	No
MST-9P04-410	101.6 ± 3.2 (4 ± 0.125)									

Axial probes for Model 410 gaussmeter

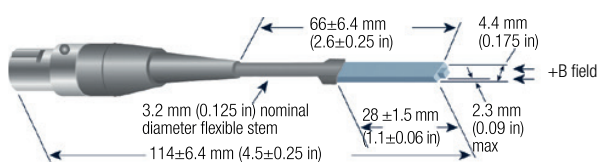

	Active area mm (in)	Stem material	Frequency range	Usable full scale ranges	Accuracy (% rdg)
MSA-410	0.13 x 0.13 (0.005 x 0.005)	Flexible plastic tubing	DC to 10 kHz	200 G, 2 kG, 20 kG	2%

Operating temp range	Temp coefficient (max) zero	Temp coefficient (max) calibration	Contains temp sensor
-10 °C to +75 °C	0.1 G/°C	-0.06%/°C	No

Brass stem axial probes for Model 410 gaussmeter

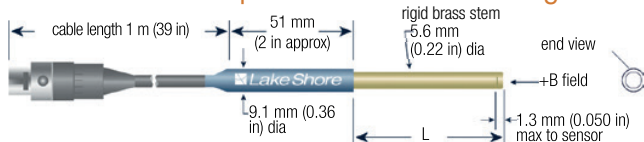

	L mm (in)	Active area mm (in)	Stem material	Frequency range	Usable full scale ranges	Accuracy (% rdg at 25 °C)	Operating temp range	Temp coefficient (max) zero	Temp coefficient (max) calibration	Contains temp sensor
MSA-2202-410	50.8 ± 3.2 (2 ± 0.125)	0.13 x 0.13 (0.005 x 0.005)	Brass	DC	200 G, 2 kG, 20 kG	2%	-10 °C to +75 °C	0.1 G/°C	-0.06%/°C	No
MSA-2204-410	101.6 ± 3.2 (4 ± 0.125)									

Hall probes

Magnetic accessories

Reference magnets

High quality reference magnets are available in transverse (flat) and axial (round) configurations—also see Helmholtz coil low field references on page 57.

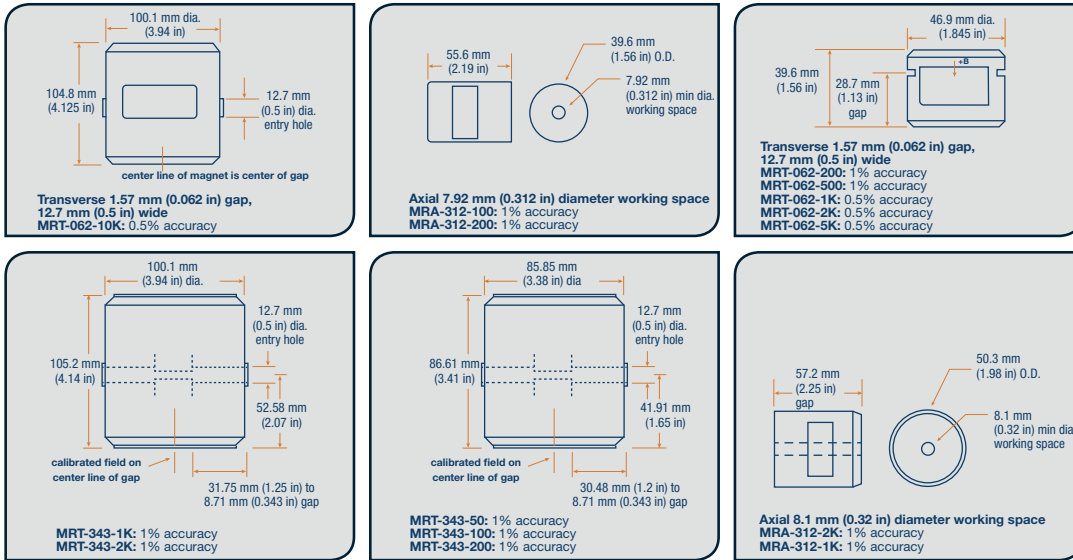

Zero gauss chambers

To obtain a null field reference, a zero gauss chamber must be used to shield the probe sensing area from external field.

	Size	Bore
4060 – Standard	33 mm × 33 mm × 61 mm (1.3 in × 1.3 in × 2.4 in)	13 mm diameter × 51 mm (0.5 in diameter × 2 in)
4065 – Large	58 mm × 53 mm × 305 mm (2.3 in × 2.1 in × 12 in)	19 mm diameter × 279 mm (0.75 in diameter × 11 in)

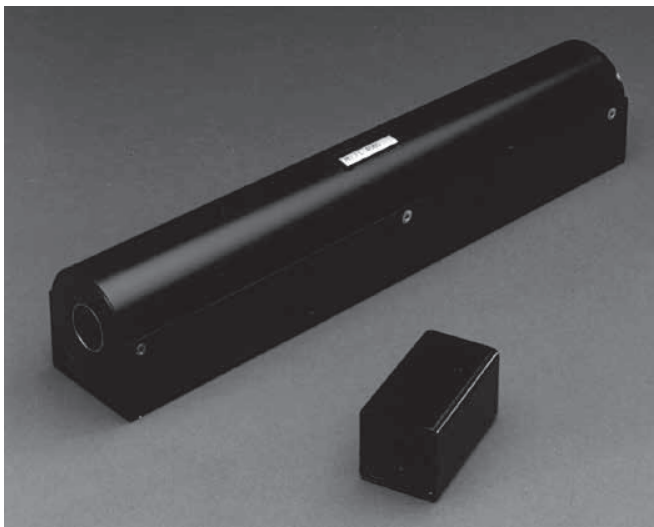

4060 Zero gauss chamber

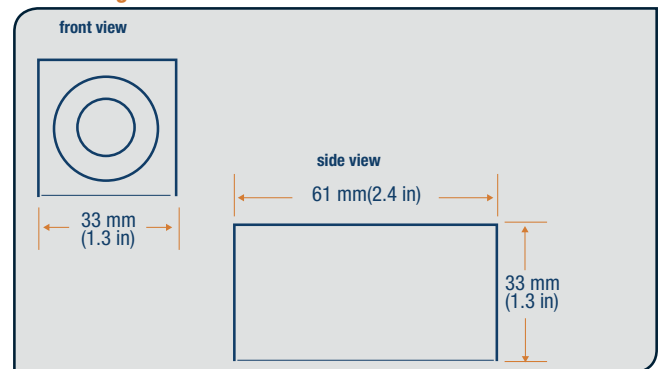

4065 Zero gauss chamber

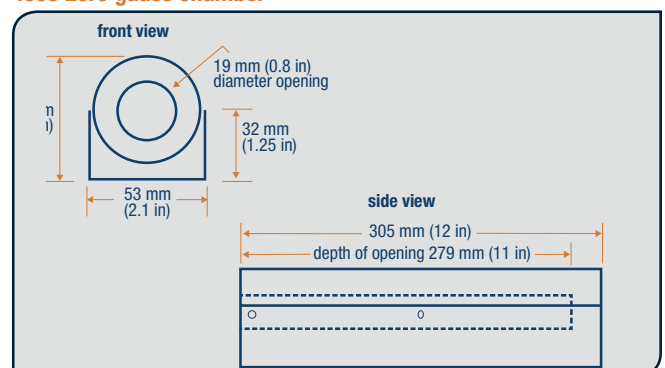

Hall probes Accessories

Hall probe stands

These moveable probe stands consist of a 30 mm (1.2 in) square post mounted on a 180 mm × 130 mm × 22.5 mm (7.1 × 5.1 × 0.9 in) thick base plate. A probe holder is integrated into the stand. The holder can be moved up or down and fixed at any angle and location along the post. Two standard models are available. Consult Lake Shore for other post heights.



Extension cables

To maintain probe accuracy, probes and extension cables for Models 460, 450, and 421 must be calibrated together at Lake Shore. When ordering an extension cable and more than one probe, it is necessary to specify with which probe the cable will be used. It should be noted that probes will exhibit their full accuracy specifications when used without an extension cable. Model 460 2- and 3-axis probes require 2- and 3-extension cables, respectively. Extension cables for Models 475 and 455 are field programmable, but can be ordered factory-calibrated.

Probe extension cables for Model 460, 450, and 421 gaussmeters

	Length
MPEC-10	3 m (10 ft)
MPEC-25	7.6 m (25 ft)
MPEC-50	15 m (50 ft)
MPEC-100	30 m (100 ft)

Probe extension cables for Model 475 and 455 gaussmeters

	Length
HMPEC-10	3 m (10 ft) calibrated
HMPEC-10-U	3 m (10 ft) uncalibrated
HMPEC-25	7.6 m (25 ft) calibrated
HMPEC-25-U	7.6 m (25 ft) uncalibrated
HMPEC-50	15 m (50 ft) calibrated
HMPEC-50-U	15 m (50 ft) uncalibrated
HMPEC-100	30 m (100 ft) calibrated
HMPEC-100-U	30 m (100 ft) uncalibrated

Ordering information

Part number Description

Extension cables

HMPEC-10	475/455 probe extension cable with EEPROM (10 ft), calibrated
HMPEC-10-U	475/455 probe extension cable with EEPROM (10 ft), uncalibrated
HMPEC-25	475/455 probe extension cable with EEPROM (25 ft), calibrated
HMPEC-25-U	475/455 probe extension cable with EEPROM (25 ft), uncalibrated
HMPEC-50	475/455 probe extension cable with EEPROM (50 ft), calibrated
HMPEC-50-U	475/455 probe extension cable with EEPROM (50 ft), uncalibrated
HMPEC-100	475/455 probe extension cable with EEPROM (100 ft), calibrated
HMPEC-100-U	475/455 probe extension cable with EEPROM (100 ft), uncalibrated
MPEC-10	460/450/421 calibrated probe extension cable (10 ft)
MPEC-25	460/450/421 calibrated probe extension cable (25 ft)
MPEC-50	460/450/421 calibrated probe extension cable (50 ft)
MPEC-100	460/450/421 calibrated probe extension cable (100 ft)
MPEC-410-10	410 universal probe extension cable (10 ft)
MPEC-410-3	410 universal probe extension cable (3 ft)

Hall probe stands

4030-12	Hall probe stand, 12 in post, accepts 3/8 in dia. Hall probe handle
4030-24	Hall probe stand, 24 in post, accepts 3/8 in dia. Hall probe handle

Zero gauss chambers

4060	Small zero gauss chamber
4065	Large zero gauss chamber

Reference magnets

MRA-312-100	Axial reference magnet: 0.312 in inside diameter, 100 G, 1%
MRA-312-200	Axial reference magnet: 0.312 in inside diameter, 200 G, 1%
MRA-312-300	Axial reference magnet: 0.312 in inside diameter, 300 G, 1%
MRA-312-500	Axial reference magnet: 0.312 in inside diameter, 500 G, 1%
MRA-312-1K	Axial reference magnet: 0.312 in inside diameter, 1 kG, 1%
MRA-312-2K	Axial reference magnet: 0.312 in inside diameter, 2 kG, 1%
MRT-062-200	Transverse reference magnet: 0.062 in gap, 200 G, 1%
MRT-062-500	Transverse reference magnet: 0.062 in gap, 500 G, 1%
MRT-062-1K	Transverse reference magnet: 0.062 in gap, 1 kG, 0.5%
MRT-062-2K	Transverse reference magnet: 0.062 in gap, 2 kG, 0.5%
MRT-062-5K	Transverse reference magnet: 0.062 in gap, 5 kG, 0.5%
MRT-062-10K	Transverse reference magnet: 0.062 in gap, 10 kG, 0.5%
MRT-343-50	Transverse reference magnet: 0.343 in gap, 50 G, 1%
MRT-343-100	Transverse reference magnet: 0.343 in gap, 100 G, 1%
MRT-343-200	Transverse reference magnet: 0.343 in gap, 200 G, 1%
MRT-343-1K	Transverse reference magnet: 0.343 in gap, 1 kG, 1%
MRT-343-2K	Transverse reference magnet: 0.343 in gap, 2 kG, 1%

All specifications are subject to change without notice