

# Helmholtz coils



## Field standards

- Field accuracy of 0.75%
- Field uniformity of 0.5%\*
- Standard field coil (field generation)
- Maximum field strengths from  $\approx 26$  G to  $\approx 60$  G
- Single axis configuration with 2.5 in, 6 in, and 12 in diameter coils

## Magnet moment measurement

- Calibration accuracy of 0.5%
- Use with Model 480 fluxmeter only
- Inspection and research of magnets (measure moment)
- Single and 2-axis configurations with 2.5 in, 6 in and 12 in diameter coils



\*Model dependent, see technical specifications

# Helmholtz coils

## Field standards

for use with current source or power supply only

We offer 4 Helmholtz coils for field standards: 64 mm (2.5 in), 152 mm (6 in), and 305 mm (12 in) diameter single-axis, and the MX-2X-10 double-axis.

|   | MH-2.5   | MH-6   | MH-12  | MH-2X-10   |
|---|--|--|--|--|
| Field accuracy (center)                 | 0.75%  |  |  |  |
| Inside diameter                         | 64 mm (2.5 in)   | 152 mm (6 in)  | 305 mm (12 in)   | 305 mm (12 in) x-axis and 248 mm (9.75 in) y-axis            |
| Field strength                          | ≈30 G/A  | ≈25 G/A  | ≈13 G/A  | ≈30 G/A<br>(note: coils are not exactly matched)             |
| Max continuous current                  | 2 A (DC or RMS)  |  |  |  |
| Field uniformity                        | 0.5% within a cylindrical volume 19 mm (0.75 in) long, 19 mm (0.75 in) diameter, at center of coil | 0.5% within a cylindrical volume 41 mm (1.6 in) long, 41 mm (1.6 in) diameter, at center of coil | 0.5% within a cylindrical volume 76 mm (3.0 in) long, 76 mm (3.0 in) diameter, at center of coil | ≈0.5% within a 64 mm (2.5 in) cube, at center of coil        |
| DC coil resistance/ inductance (approx) | 3 Ω/6.3 mH   | 10 Ω/36 mH   | 20 Ω/93 mH   | 20 Ω (x-axis), 15 Ω (y-axis)/128 mH (x-axis), 74 mH (y-axis) |
| Operating temp range                    | -20 °C to 40 °C (-4 °F to 104 °F)  |  |  |  |

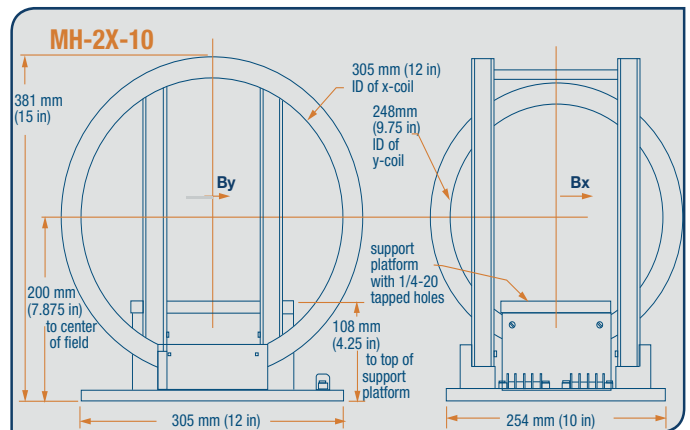
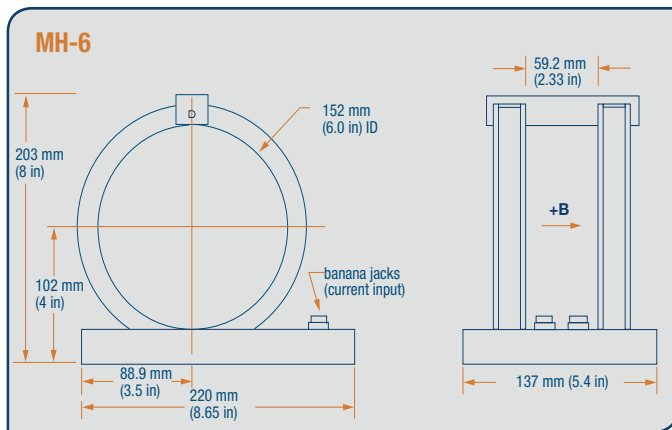
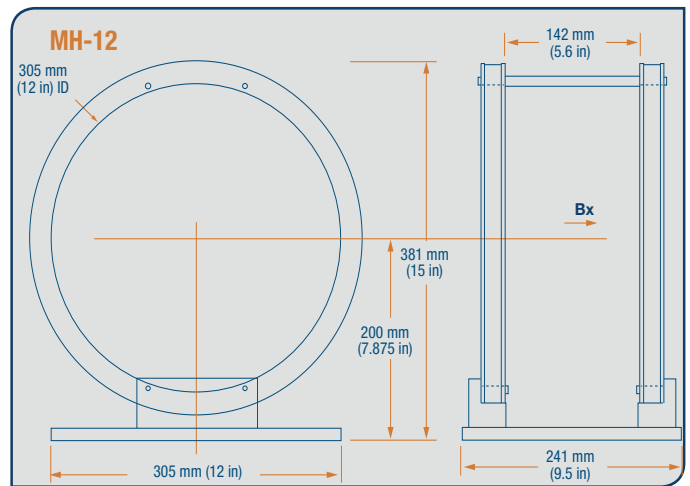
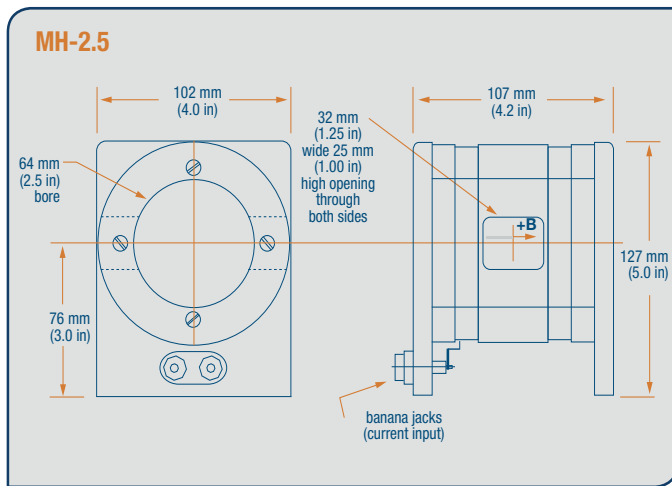

### Ordering Information

| Part number | Description  |
|-------------|--|
| MH-2.5      | 64 mm (2.5 in) inside diameter, maximum field approximately 60 G   |
| MH-6        | 152 mm (6 in) inside diameter, maximum field approximately 50 G  |
| MH-12       | 305 mm (12 in) inside diameter, maximum field approximately 26 G   |
| MH-2X-10    | 305 mm (12 in) inside diameter (x-axis), 248 mm (9.75 in) inside diameter (y-axis), maximum field approximately 30 G |

**NOTE:** The MH Series coils are for use as low field standards. They cannot be used with the Model 480 fluxmeter.

All specifications are subject to change without notice