

# MeasureReady MCS modular characterization systems EMP electromagnet platforms

## Measure Ready

Research platforms that quickly adapt to a wide range of material characterization applications, now and into the future.

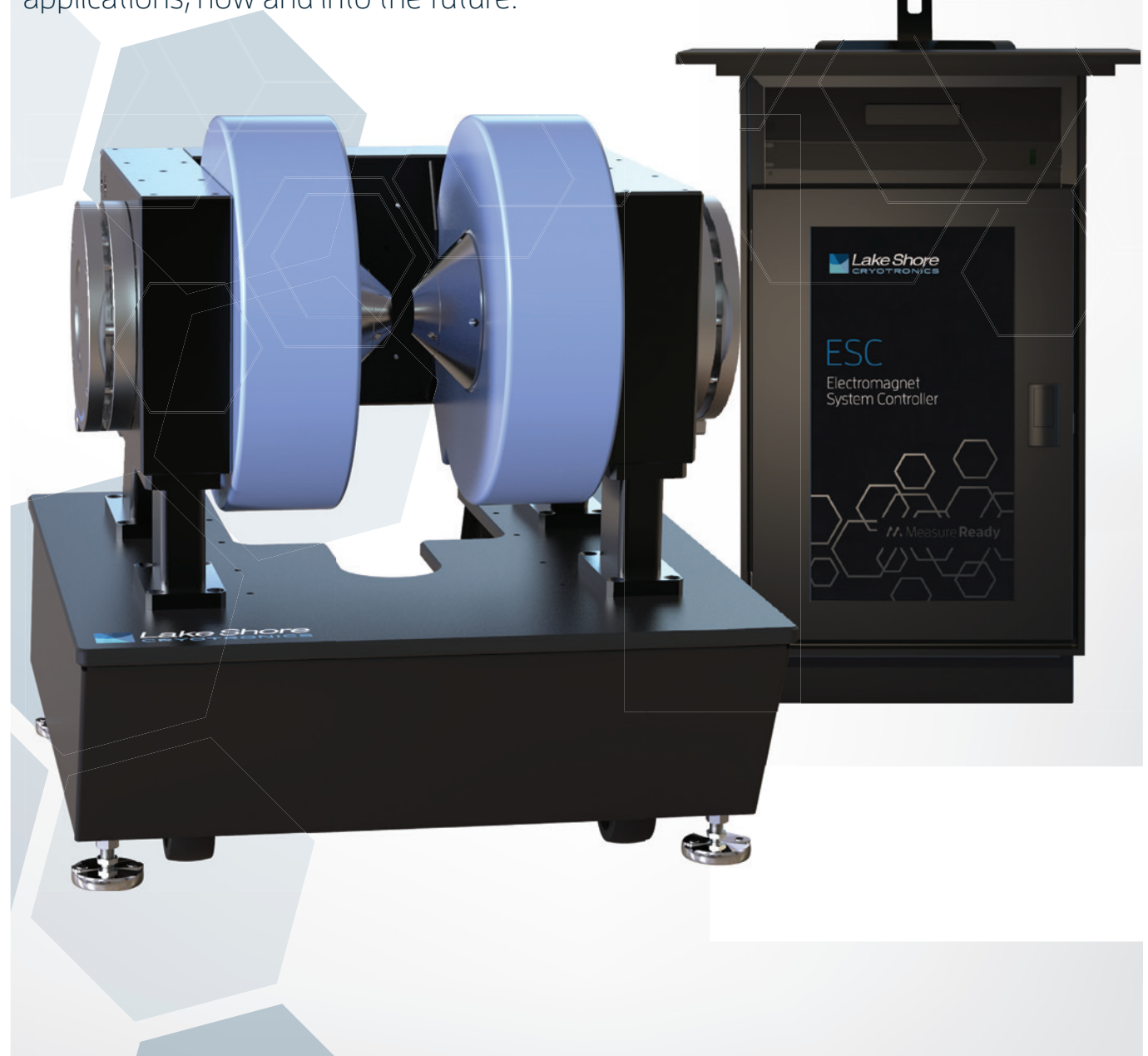

# MeasureReady MCS modular characterization systems EMP electromagnet platforms

**Measure Ready**

## MCS Series Modular Characterization Systems

*Research platforms that quickly adapt to a wide range of material characterization applications, now and into the future.*

### MCS-EMP Electromagnet platform

#### Key features

- Variable magnetic fields to over 3 T
- Low-noise 4-quadrant power supply
- Integrated teslameter for closed loop field control
- MeasureLINK™-MCS control software license and script library

#### Measurement options

- Fully-integrated measurement modules, e.g., Hall effect
- Measurement instrumentation
- Variable temperature
- Sample holders

#### Typical applications

- Electronic/electro-transport measurements
- Magnetic/magneto-transport measurements
- Specialized, customer-built measurements



### MCS-CPS Cryogenic probe station

#### Key features

- Automated temperature control
- Automated field control

**Coming in 2020**



# MeasureReady MCS modular characterization systems EMP electromagnet platforms

more science.  
less time.



# MeasureReady MCS modular characterization systems EMP electromagnet platforms

## MCS Modular Characterization System EMP Electromagnet platform

The multi-purpose MCS-EMP electromagnet platform provides all of the essential components required for automated, variable field experiments. Each MCS-EMP builds on a 4-inch or 7-inch electromagnet with pole caps, magnet base, and pedestal. Magnets feature ExactGAP™ precision-settable sample gaps. 2-inch pole caps are standard on the 4-inch MCS-EMP, and convertible 4-inch/2-inch caps are standard on the 7-inch MCS-EMP. Optical access is optional.

### Included with each MCS-EMP:

- 4 in or 7 in electromagnet
- **Electromagnet system controller (ESC):**
  - High-reliability linear magnet power supply (643 or 648)
  - F71 multi-axis teslameter and single-axis field-monitoring probe
  - PC with installed MeasureLINK™-MCS control software
  - Equipment console

### MCS-EMP choices

- GlideLOCK option mount only
- Variable temperature control with GlideLOCK mount
- Optical bore

Shown with optional sample holder in GlideLOCK™ mount

Electromagnet  
(power supply not shown)



Electromagnet system controller (ESC)

# MeasureReady MCS modular characterization systems EMP electromagnet platforms

## System modules and options MCS-EMP Electromagnet platform



### Electronic measurement modules

#### FastHall™ Hall effect

(Others to come)



### Temperature options

#### GlideLOCK™ oven

CCR/CCR-O



### Temperature control



### Sample options

High performance sample holder/insert and cards

Room temperature top-side optical access

Manual rotation



### Compatible measurement instruments

155 precision current/voltage source

372/3708 AC resistance bridge

Add your own third-party instruments



# MeasureReady MCS modular characterization systems EMP electromagnet platforms

## Electromagnet system controller (ESC)

The ESC comprises the control software and instruments/equipment that turn the electromagnet into a robust and flexible measurement platform.

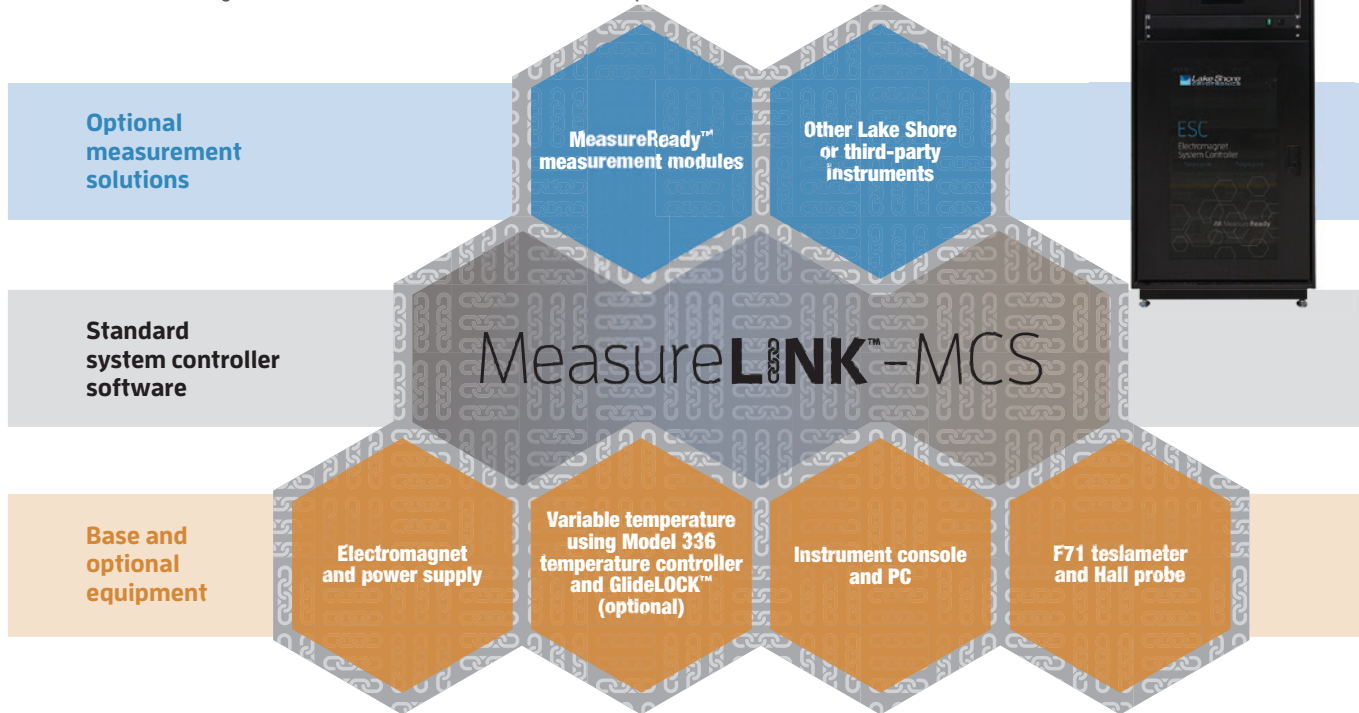

## Other notable details of MCS-EMP components

### Precise, repeatable pole gaps

ExactGAP™ pole gap indexing minimizes delays when an option change is required. Use preset gap settings for each temperature option or sample holder to quickly move the caps to a precise, precalibrated position repeatedly without having to manually recalibrate for each setting.

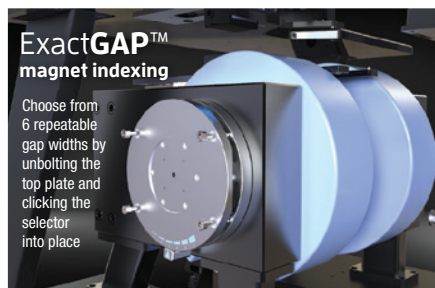

### Teslameter with TruZero™

The F71 multi-axis teslameter's TruZero™ technology eliminates errors that plague magnetic field measurements, allowing you to take measurements with confidence. The TiltView™ display is comfortable to see and operate, and the uncluttered touchscreen uses navigation familiar to any smartphone user.



F71 teslameter (used with electronic measurement modules)

### Robust power supplies

The 648 and 643 electromagnet power supplies are specifically designed for high precision laboratory use requiring extremely low electrical noise. The linear design removes undesirable higher frequency noise typical of switch mode power supplies. Eliminating the need for external switching or operator intervention to reverse current polarity, they use convenient bipolar, 4-quadrant operation. They are built to last with a rugged design, integrated fault protection, and a simple, clean interior electronic design.



# MeasureReady MCS modular characterization systems EMP electromagnet platforms

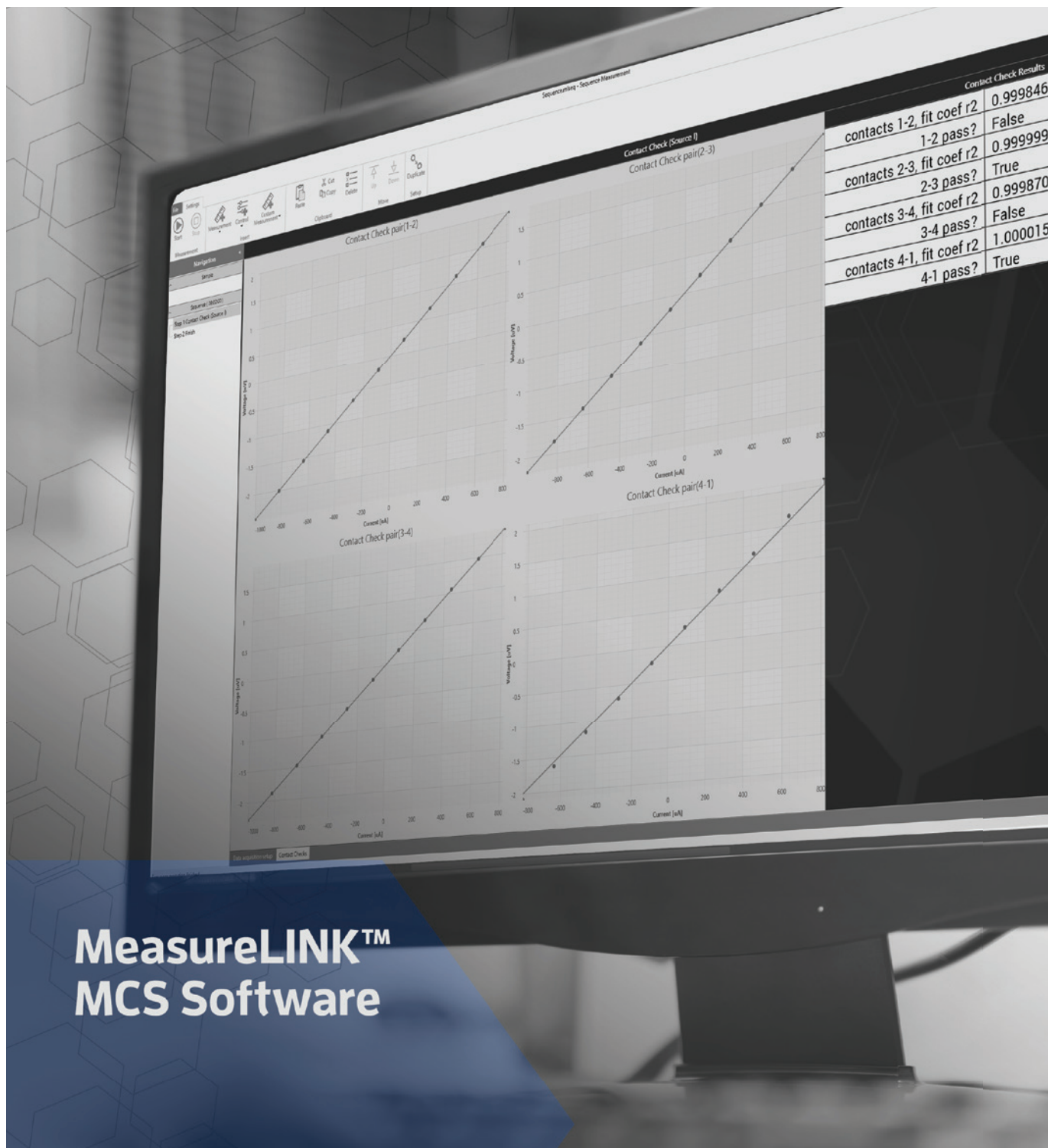

**MeasureLINK™**  
**MCS Software**

# MeasureReady MCS modular characterization systems EMP electromagnet platforms

## MeasureLINK™-MCS software

MeasureLINK-MCS software is the key component of each MeasureReady™ MCS system. It facilitates field control, temperature control, measurement sequencing, and integration functions.

This flexible software allows the user to monitor the real-time performance of the MCS system and to construct measurement sequences from a set of predefined controls. The menu-driven graphical user interface (GUI) provides the ability to control field and temperature to a specific setpoint or to loop these parameters through a range of settings with a specified step value. The sequences can be saved and recalled for use in repeated measurements.

## MeasureLINK™-MCS software features

- Temperature and field control
- Measurement sequences
- Integrate Lake Shore or third-party instruments
- Integration with other lab software
- Custom measurements with scripting

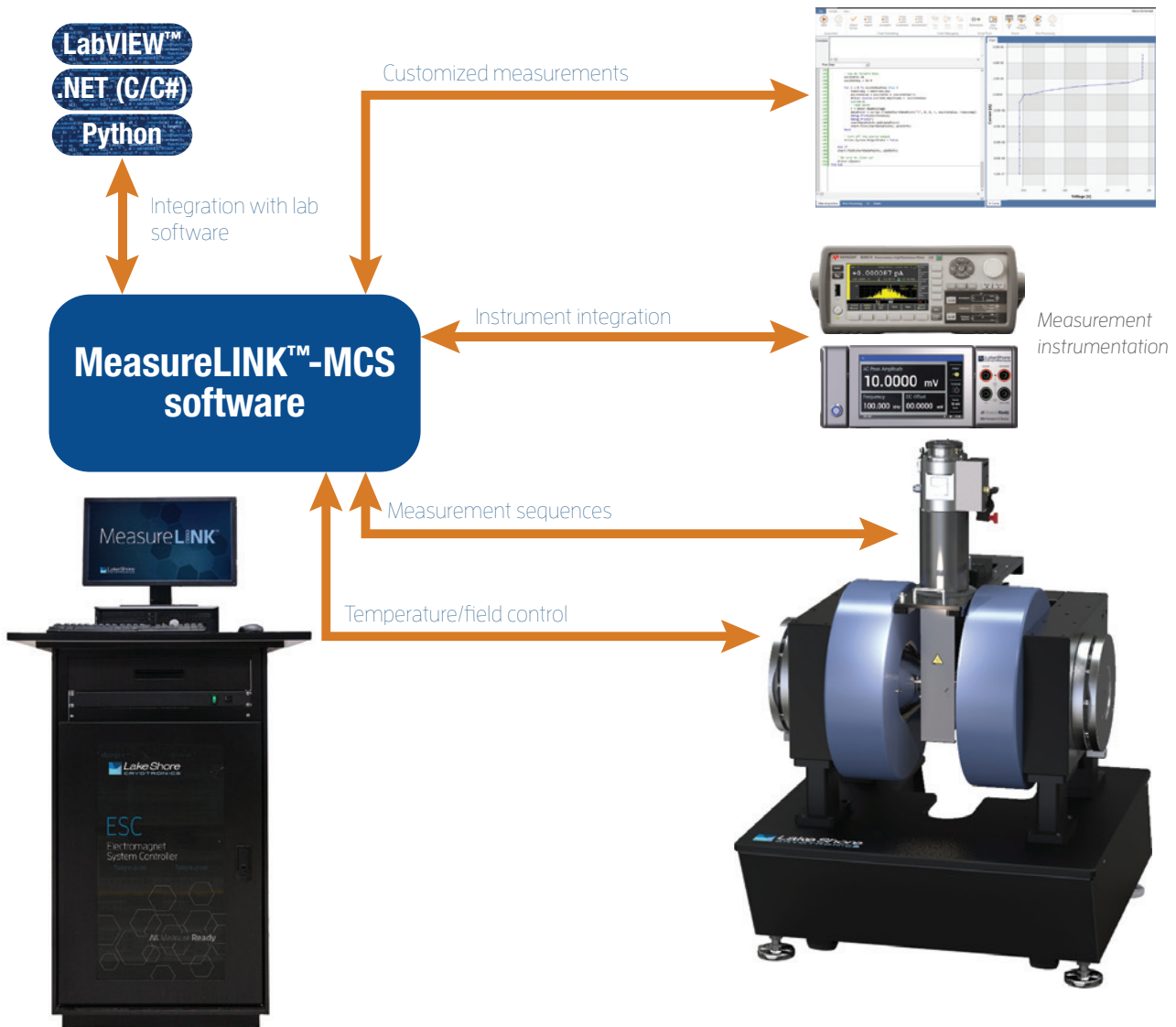



# MeasureReady MCS modular characterization systems EMP electromagnet platforms

## Home screen

### Three main functions:

- Sample setup
- Sequencing
- Scripting

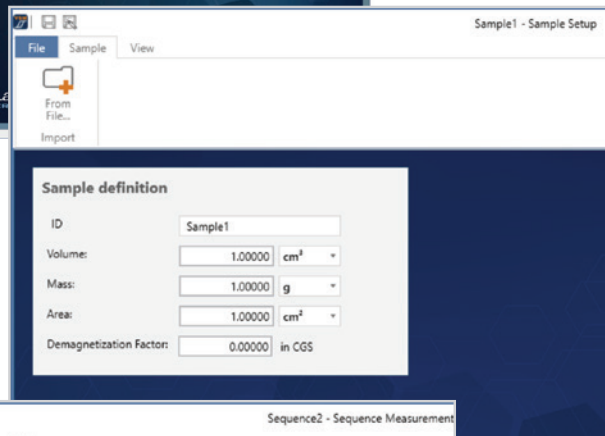
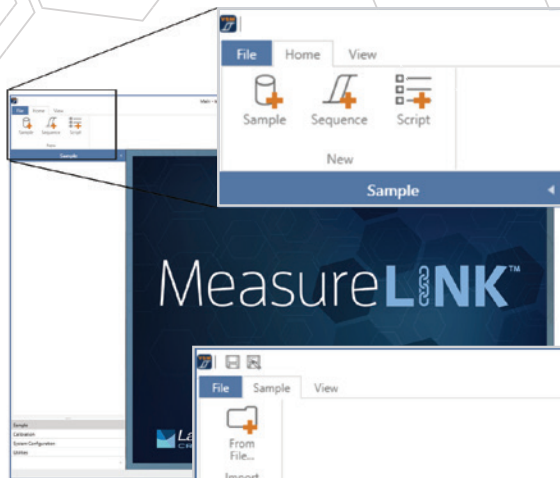

## Sample setup screen

Associate sample information with a measurement sequence

Enter new sample information directly

Import sample information from previously-saved file

## Sequence screen

Build a sequence of steps that define the desired measurement protocol

Choose from:

### Measurement functions

- Built-in functions

### Control functions

- Go to field or temperature
- Loop field or temperature

### Custom measurements

- Modified or specialized routines, previously defined by scripts

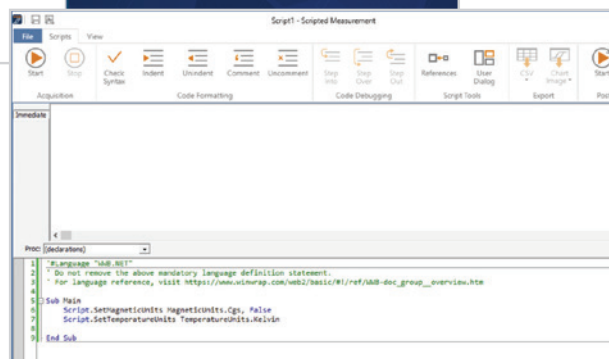
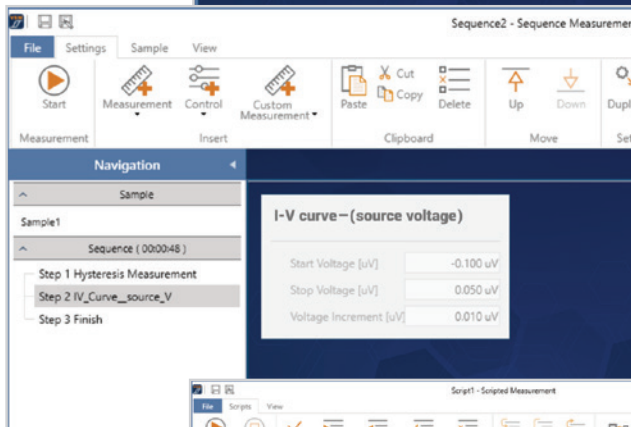

## Script screen

Extend your system functionality by creating custom scripts

- Implement nearly any measurement
- Integrate third-party instruments

Modify existing scripts

Import other scripts

# MeasureReady MCS modular characterization systems EMP electromagnet platforms

## Scripting example

### I-V measurement

Loop through 20 voltage steps

- Set V
- Measure I

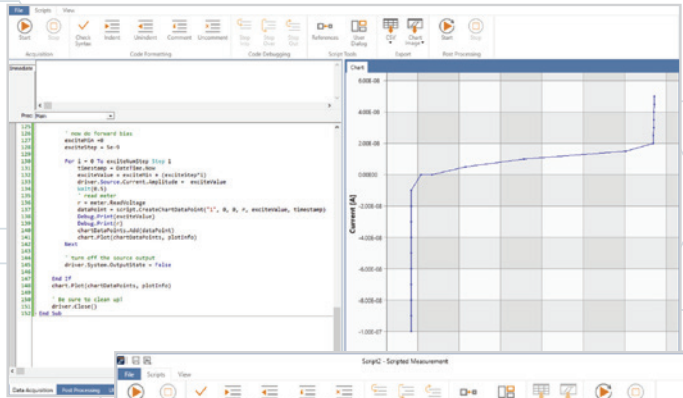

Scripting tool enables presentation of a simple user interface

- Start voltage
- Finish voltage
- Number of steps

Once script is ready

- Add to Custom Measurement list
- Select and add the custom script to the sequence steps from the drop-down list
- Appears exactly like built-in functions

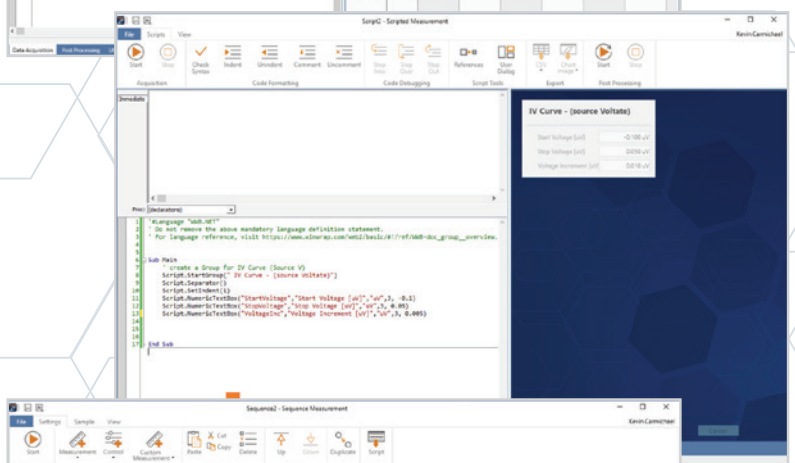

Customized measurement sequence

- Executes sequential steps as defined
- Presents UI steps such as data entry windows
- Custom scripts execute like other steps
- Data collection and graphing can be included

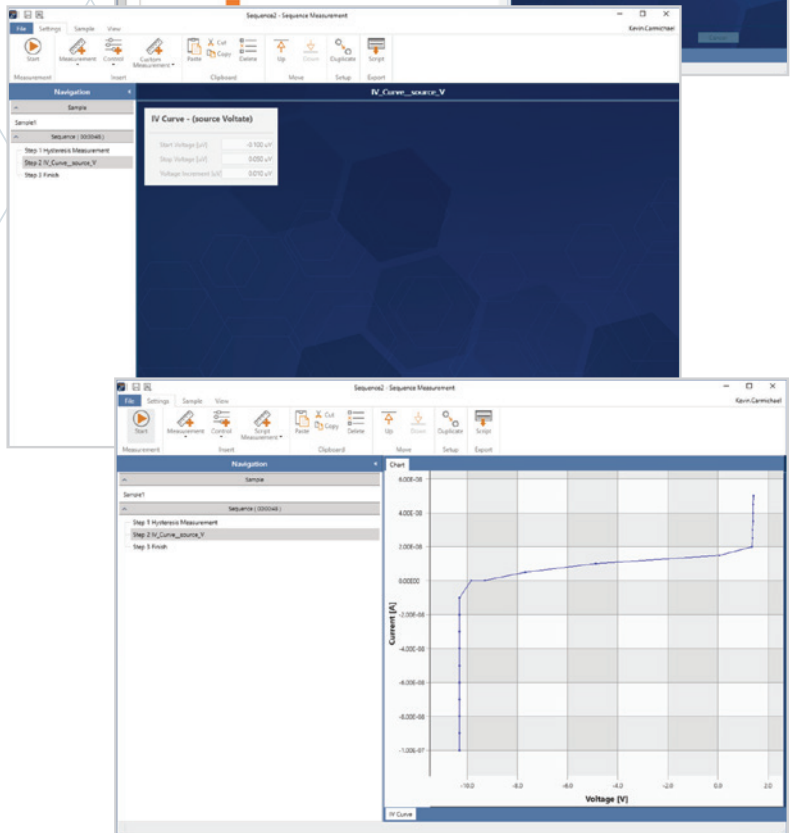

# MeasureReady MCS modular characterization systems

## EMP electromagnet platforms

### A faster path to your research results

Unlike other pre-defined limited-purpose measurement systems, the MeasureReady™ Modular Characterization System (MCS) is built to be flexible, expandable, and easily modified as research needs change.

Even if you are studying electronic properties of a new semiconductor material one day, then want to make magneto-transport measurements of a prototype nanomagnet the next day, the MCS accommodates your varying experimental setups while enabling you to get the most out of your equipment investment.

The system features Lake Shore's versatile MeasureLINK™-MCS software, a highly configurable application that enables researchers to use and modify measurement scripts from a library supplied with the platform, or create entirely new ones to accommodate custom measurement protocols.

MeasureLINK-MCS also provides a straightforward and open method for integrating third-party instrumentation into the platform using industry-standard protocols. The software integrates readily with supervisory packages such as LabVIEW™ to the extent needed for each experiment.

You can further extend your MCS with one or more MeasureReady measurement modules, such as complete Hall effect measurement featuring Lake Shore's patented FastHall™ technology.

# MeasureReady MCS modular characterization systems EMP electromagnet platforms



# MeasureReady MCS modular characterization systems EMP electromagnet platforms

## MeasureReady

### FastHall™ Hall effect measurement module

New semiconductor and electronic materials being developed for applications such as photovoltaic (solar cell) and thermoelectrics, displays including organic electronics, and high power devices can have electronic properties that are increasingly difficult to measure. Traditional DC field electronic transport property measurement systems cannot measure many of these materials due to their low charge carrier mobilities and the high temperatures needed to characterize high power devices. AC field measurement improves resolution in some cases, but measurement times can become quite long with some materials.

Increasingly, novel materials can have mobilities below  $1 \text{ cm}^2/\text{V s}$ . The challenge is to extract the diminishingly small Hall voltage from the background noise they produce. A new measurement method is needed. Lake Shore has recently developed its patented new FastHall™ technology for making these difficult measurements much faster and with far more accuracy than has previously been possible. This is nothing less than a significant breakthrough in research productivity.

The FastHall Hall effect measurement module includes:

- MeasureReady™ M91-HR FastHall™ measurement controller with high resistance option
- MeasureLINK™-MCS HMS application pack
- MCS-EMP-HP-BODY room temperature high performance sample holder and insert
- Triaxial cables, other cables, and cable management system
- Sample card kit
- Rack mount kit

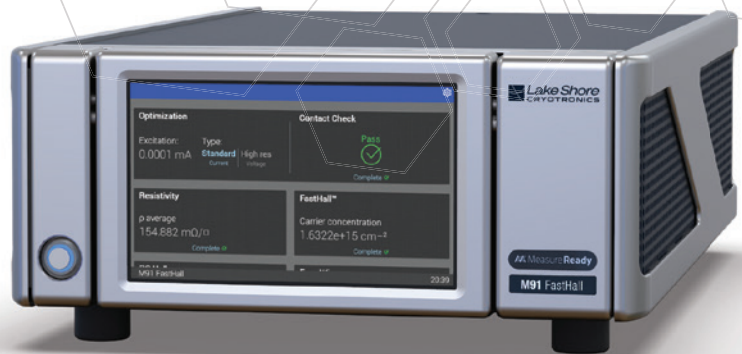

## MeasureLINK™

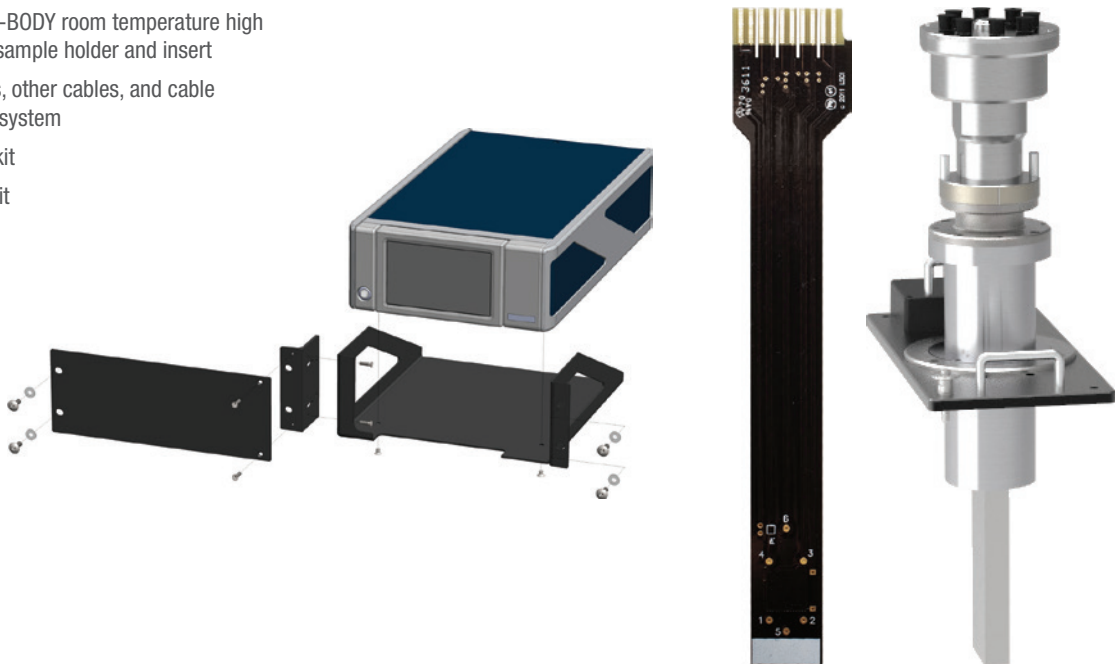
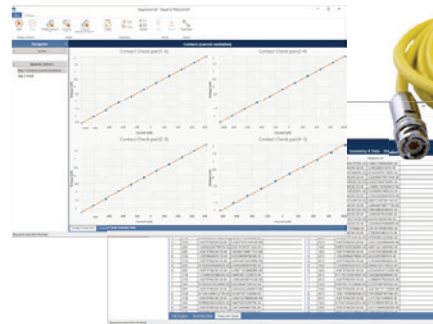

# MeasureReady MCS modular characterization systems EMP electromagnet platforms

## MeasureReady™ M91 FastHall™ Measurement Controller

### A convenient, single instrument

Traditional Hall effect measurement systems (HMS) provide basic electrical measurement instrumentation combined with a generic switch unit to measure sample resistivity and Hall voltages, but must rely on separate PC-based software to perform pre- and post-processing calculations in order to ultimately derive the physical parameters of carrier type, carrier concentration, mobility, and the Hall coefficient that researchers need to know.

The MeasureReady™ M91 FastHall™ measurement controller combines all of the necessary HMS functions into a single instrument, automating and optimizing the measurement process, and directly reporting the desired parameters. Adding HMS capabilities to any research platform has never been easier.

- Removes the need for field reversal
- Applicable to any magnet type
- Up to 100x faster for low mobility materials
- Improves accuracy by minimizing thermal drift

### Fields of study and research

#### Photovoltaic and thermoelectric applications

Photovoltaic (solar cell) and thermoelectric materials are often characterized by low mobilities. This characteristic makes them difficult or impossible to measure using traditional DC field Hall methods. The FastHall™ measurement module makes it possible to easily characterize these materials.

#### Organics

The FastHall module can reliably measure the Hall effect in low mobility organic electronics. These materials are the basis for printable and flexible electronic devices, as well as organic light emitting diodes and organic solar cell materials.

### Fast – ideal for low mobility materials

Hall effect measurement is a key step in characterizing the transport properties of novel electronic materials and devices. It is commonly performed using the traditional DC field method, requiring little more than a stable DC current source, a voltmeter, a switch and a magnet and is relatively straightforward and reliable for simpler materials with higher mobilities. However, the difficulty increases and accuracy of measurement decreases as material mobilities decrease. This is often the case in promising new semiconductor materials such as photovoltaics, thermoelectrics, and organics.

For the past several years, AC field techniques using advanced lock-in amplifiers and longer measurement windows to extract smaller Hall voltage signals have been used to explore these materials. But extended measurement intervals can also add new forms of error from thermal drift effects. And, of course, results take longer to get, sometimes many hours for very low mobility materials.

The FastHall technique eliminates both of these issues—it accurately measures even extremely low mobility materials in seconds.

### Materials

#### Solar cells

OPVs, a-Si,  $\mu$ c-Si, CdTe, CuInGaSe (CIGS)

#### Organic electronics

OTFTs, pentacene, chalcogenides, OLEDs

#### Transparent conducting oxides

InSnO (ITO), ZnO, GaZnO, InGaZnO (IGZO)

#### III-V semiconductors

InP, InSb, InAs, GaN, GaP, GaSb, AlN based devices, high electron mobility transistors (HEMTs) and heterojunction bipolar transistors

#### II-VI semiconductors

CdS, CdSe, ZnS, ZnSe, ZnTe, HgCdTe

#### Elemental semiconductors

Ge, Si on insulator devices (SOI), SiC, doped diamond  
SiGe based devices: HBTs and FETs

#### Dilute magnetic semiconductors

GaMnAs, MnZnO

#### Other conducting materials

Metal oxides  
Organic and inorganic conductors

#### High temperature superconductors

### Others' approach

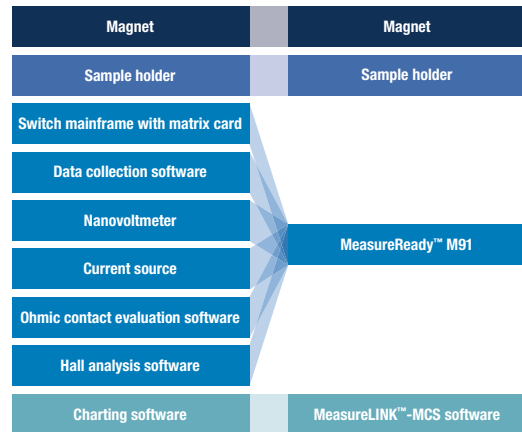

### FastHall™ approach

FastHall vs. conventional Hall measurement time of an IGZO sample



# MeasureReady MCS modular characterization systems

## EMP electromagnet platforms

	FastHall™	AC field	DC field
Eliminates field reversal	✓	✗ AC field (sinusoidal)	✗
Can be used with permanent magnets	✓ FAST	✗	✓ MANUAL
Can be used with electromagnets	✓ FAST	✓ SLOWER WITH LOWER MOBILITIES	✓ SLOWER WITH LARGE ELECTROMAGNETS
Can be used with superconducting magnets	✓ FASTER THAN DC FIELD	✗	✓ VERY SLOW
Measurement capability	Lower mobility: ~10 <sup>-3</sup> cm <sup>2</sup> /V s and up	Lower mobility: ~10 <sup>-3</sup> cm <sup>2</sup> /V s and up	Higher mobility: ~1 cm <sup>2</sup> /V s and up



Executes a complete Hall measurement sequence:

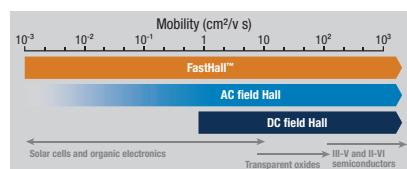

Please see [www.lakeshore.com/M91](http://www.lakeshore.com/M91) for more information

# MeasureReady MCS modular characterization systems EMP electromagnet platforms

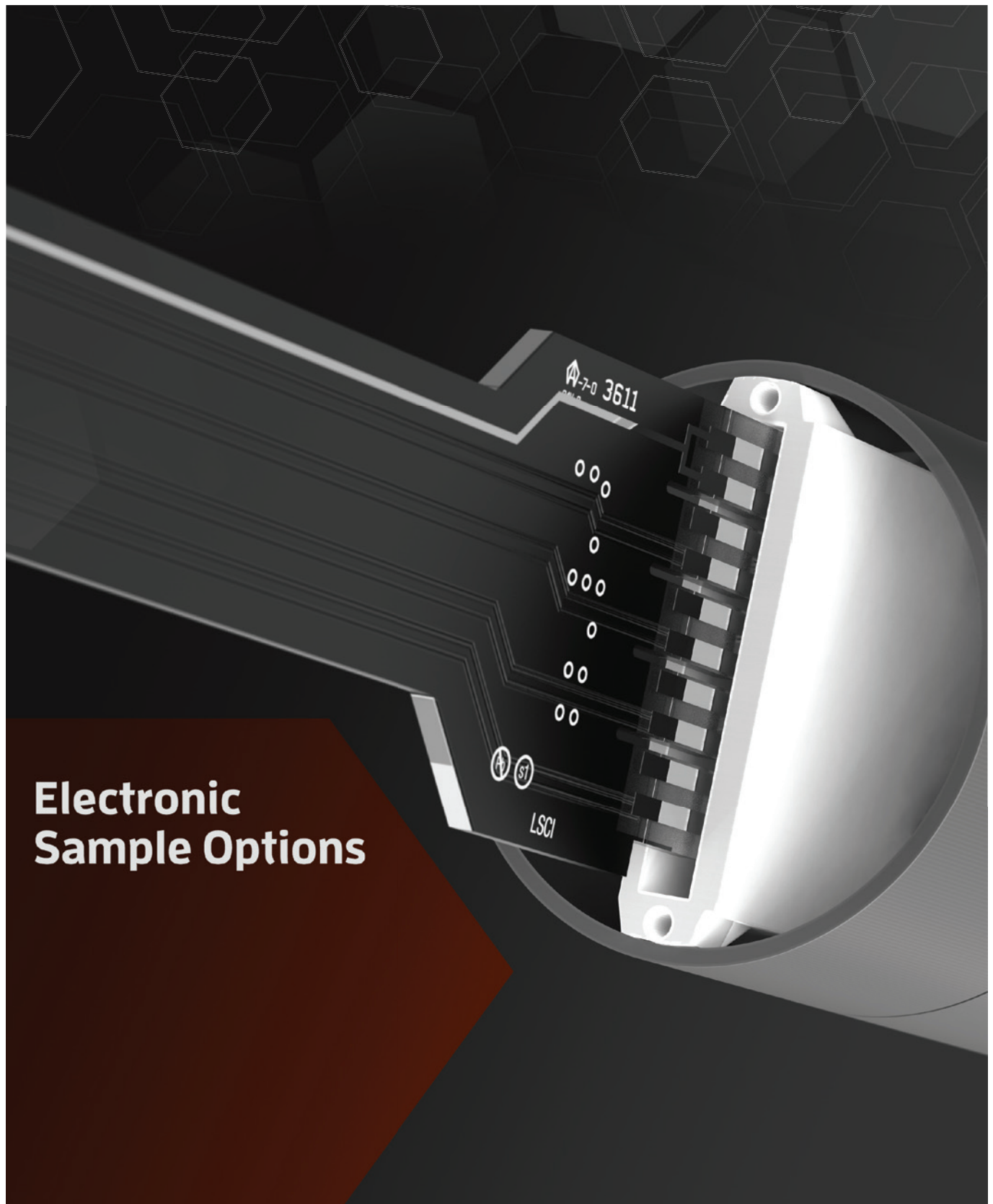

## Electronic Sample Options



# MeasureReady MCS modular characterization systems

## EMP electromagnet platforms

### Room temperature sample holders

#### High performance insert and the room temperature light tight body

##### Insert

The MCS-EMP-HP-SI high performance insert provides physical mounting and electrical connection to the sample card. The standard insert is compatible with the light tight body and optical access body for operation at room temperature. The insert includes eight triaxial connectors for guarded signals to the sample for resistance measurements (up to 200 GΩ) depending on your system's configuration. Its circular connector contains temperature monitor leads, insert identification, and safety interlock. The standard insert is compatible with a variety of standard and optional sample cards.

##### Room temperature light tight body



The MCS-EMP-HP-BODY light tight body serves as a support for the included standard insert, allows for consistent sample alignment, and provides a light-tight, draft-free environment for the sample. It is designed to fit a 25 mm (1 in) magnet air gap. It is also compatible with all standard and optional sample cards. Optional optical access is available (MCS-EMP-BODY-O).



The triaxial cables being attached to the insert



Sliding a sample card into the insert



MCS-EMP-HP-SI inserted into MCS-EMP-HP-BODY

##### Room temperature top-side optical access body

Optical access allows you to expose samples to different wavelengths of light via a laser or fiber optic. The MCS-EMP-HP-BODY-O room temperature body adds top side optical access capability to the standard Hall high performance insert.

The MCS-EMP platform also must be configured for optical access. See page 26.

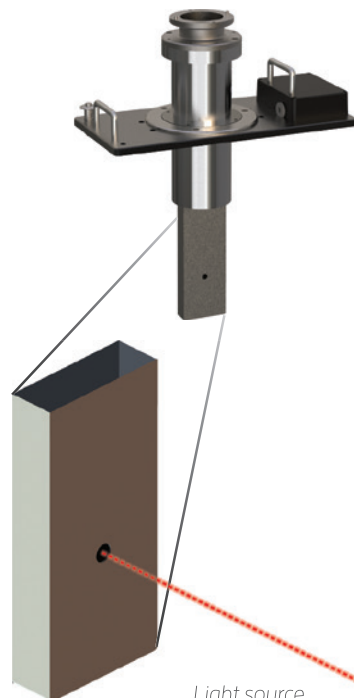

Light source illuminating the top side of the sample

# MeasureReady MCS modular characterization systems EMP electromagnet platforms

## Sample holder accessories

### For electronic material characterization

Sample measurement options provide an additional convenient solution for making electrical measurements in a magnetic field.

### High performance sample mounting cards

#### Sample cards

A variety of sample cards are available for the high performance insert to facilitate sample mounting and storage as well as expedite sample exchange. Standard plug-in sample cards allow mounting of up to a 10 mm sample. An optional card can accommodate up to a 50 mm sample. The 10 mm sample cards are available in prober pin or solder pad style while the 50 mm sample card is available in prober pin style only. The prober pin style sample cards allow you to mount your samples without requiring contact pad soldering.

Even subtle changes in room temperature can sometimes influence your measurement results. As such, our sample cards are available with an integrated platinum RTD to ensure you get the most information out of your measurement. When used in combination with the temperature monitor or control options, you can log and record small fluctuations in sample temperature, helping you gain the most knowledge of the materials you are studying.

#### Available sample cards for use with the high performance MCS-EMP-HP-SI insert include:

**MCS-EMP-HP-SC-10-P:** 10 mm prober pin sample card with PT sensor

**MCS-EMP-HP-SC-10-S:** 10 mm solder pad sample card with PT sensor

**MCS-EMP-HP-SC-50-P:** 50 mm prober pin sample card for room temperature use

**MCS-EMP-HP-FC:** Field calibration card

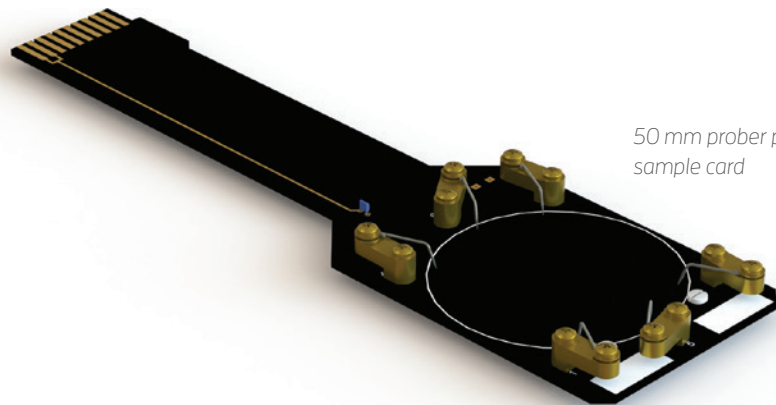

50 mm prober pin  
sample card

# MeasureReady MCS modular characterization systems

## EMP electromagnet platforms

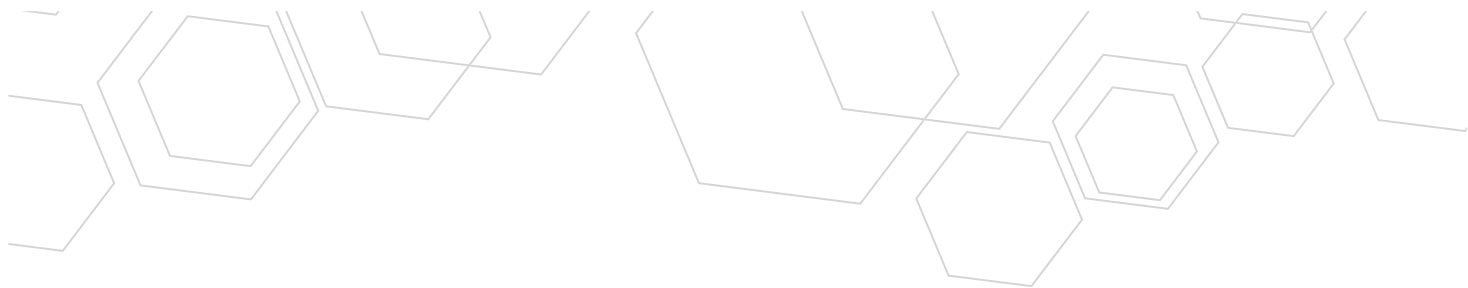

10 mm solder pad  
sample card



10 mm probe pin  
sample card



Field calibration card



### Sample rotation

The MCS-EMP-HP-ROTATE sample rotation option adds 0° to 360° manual sample rotation to your MCS-EMP. It is available as an option with the high performance light-tight body. It comes standard with the CCR option (MCS-EMP-CCR) and the oven option (MCS-EMP-OVEN). Sample rotation is usable with the 10 mm sized sample cards. It is not compatible with 50 mm cards.

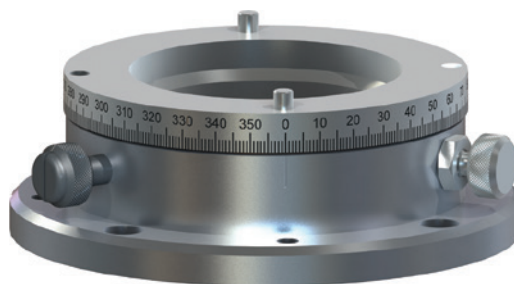

# MeasureReady MCS modular characterization systems EMP electromagnet platforms



# MeasureReady MCS modular characterization systems EMP electromagnet platforms

## Temperature options

### For electronic material characterization

Temperature options provide fixed or variable temperature sample environments that mount between the poles of the MCS-EMP.

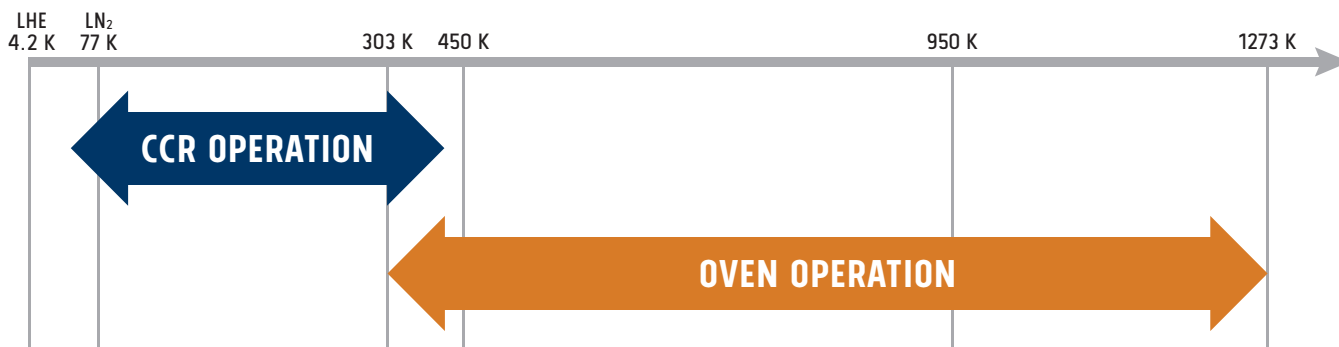

### Required for all temperature options

The MSC-EMP variable temperature kit provides the required components to support our full suite of variable temperature options. When you select this option while configuring your platform, your MCS-EMP will include a Lake Shore temperature controller, thermocouple input card (when purchased for use with the high temperature oven), GlideLOCK alignment system mount, vacuum handling kit, mounting hardware, flanges, hoses, connectors, and accessories. Must be configured as part of the base MCS-EMP platform. See page 26.

### GlideLOCK™ option alignment

GlideLOCK™ room temperature and variable temperature options slide in and out of the MCS-EMP on a precision-aligned tray, and click into place to assure repeatable positioning of the enclosed sample within the magnet poles. The MeasureLINK-MCS software further simplifies the implementation of the GlideLOCK™ options by automatically detecting and displaying each option as it is plugged into the MCS-EMP. With controllable options, the software provides automated, unattended temperature adjustment throughout the entire temperature range of that option. The GlideLOCK mechanism is included when the MCS-EMP is configured with the variable temperature kit, or can be selected independently if only room temperature measurements are needed. Must be configured as part of the base MCS-EMP platform. See page 26.

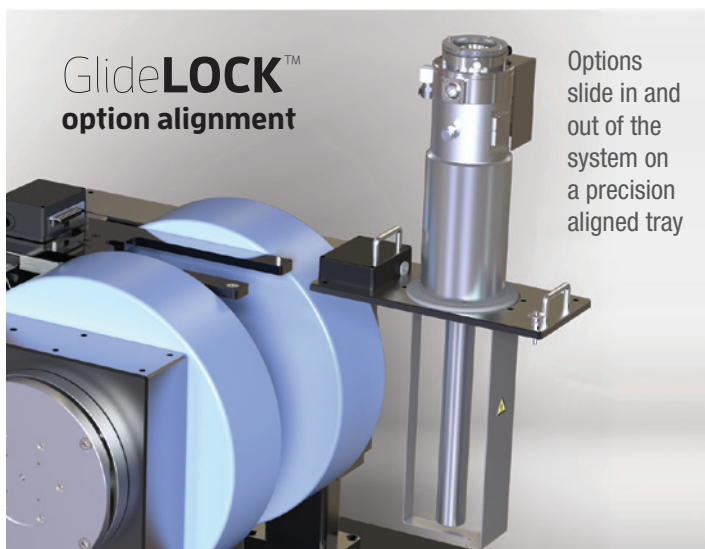

# MeasureReady MCS modular characterization systems EMP electromagnet platforms

## High performance temperature options

### High temperature oven (MCS-EMP-OVEN with insert)

The oven body and insert with GlideLOCK™ allows you to study the effects on your material as you heat your sample to as hot as 1,273 K\*. The oven insert is placed into the top of the oven body and attaches via captive thumb screws. Because the oven body and oven insert form a vacuum-tight enclosure, sample heating can be done under an inert gas atmosphere—argon is recommended. The oven insert has a temperature sensor mounted near the sample location to ensure a reliable temperature measurement feedback loop. One MCS-EMP-OVEN-SI insert is included with MCS-EMP-OVEN.



The oven single sample insert has 4 probe pins

Requires MCS-EMP with variable temperature kit, E2M vacuum pump or equivalent (compatible with TPS-FRG), Ar or He gas cylinder with regulator and hose barb.

\*At 773 K and  $\pm 1\%$  rdg: maximum = 1 M $\Omega$ ; at 1,273 K and  $\pm 1\%$  rdg: maximum = 1 k $\Omega$

### Closed cycle refrigerator

Closed cycle refrigerator (CCR) body and insert (MCS-EMP-CCR). CCRs provide a variable temperature cryogenic environment by cooling helium exchange gas. No liquid cryogenics are required, so ongoing operating costs are minimal. In order to optimize efficiency and throughput, your sample is surrounded by helium gas at a pressure slightly above atmosphere, allowing samples to be exchanged without breaking vacuum or warming the CCR. Pump out of the vacuum jacket to 100 Pa (0.1 Torr) is required prior to cool down. One MCS-EMP-CCR-SI insert is included with the MCS-EMP-CCR, as well as stand for mounting.



The CCR single sample insert has a sapphire pad and solder posts

Requires MCS-EMP with variable temperature kit, TPS-FRG vacuum pump or equivalent, LHe gas cylinder and regulator; must specify single phase (208/230, 200, 220 CE, 240 CE VAC) line voltage at order.

### Closed cycle refrigerator with optical access

CCR with sample top side optical access (MCS-EMP-CCR-O). When combined with the sample top side optical access kit and the optical access magnet, the optical access CCR allows you to study the effects that various wavelengths of light may have on your material samples at cryogenic temperatures.

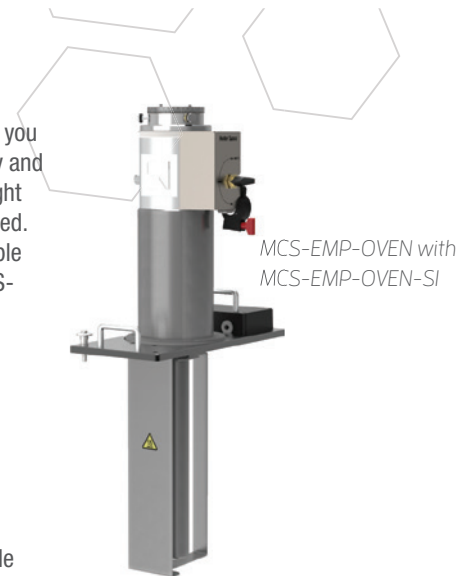

MCS-EMP-OVEN with  
MCS-EMP-OVEN-SI



MCS-EMP-CCR  
with stand

New stand design  
coming soon

# MeasureReady MCS modular characterization systems EMP electromagnet platforms

## Vacuum pumps

Used to annually evacuate the cryogen transfer line of the optional cryostat and single stage variable temperature assembly (transfer line and kit are included with these options), the TPS-FRG turbomolecular vacuum pump provides vacuum to  $1.33 \times 10^{-3}$  Pa ( $10^{-6}$  Torr). In addition to annual cryogen transfer line maintenance, the turbomolecular vacuum pump can also be used to evacuate the cryostat vacuum space. Lake Shore also offers the E2M two-stage rotary vacuum pump with mist filter.

## Recirculating chillers

Lake Shore offers recirculating chillers in order to provide a complete laboratory solution. These chillers feature a CFC-free refrigeration system.

The refrigeration system uses a hermetically sealed compressor and hot gas bypass system of temperature control. This system eliminates on/off cycling and premature wear of the compressor. Strong pumps provide continuous flow even through cooling lines with small IDs.

Contact Lake Shore for a current list of available chillers.



*Electromagnet with MCS-EMP-OVEN*



*Electromagnet with MCS-EMP-CCR*

*New stand design  
coming soon*

# MeasureReady MCS modular characterization systems EMP electromagnet platforms

## MCS-EMP Specifications (preliminary)

### APPLIED FIELD STRENGTH WITH STANDARD POLE CAPS ( $\pm 1\%$ )

ExactGAP™ setting	Air gap	EMP-4 maximum field with 4 in to 2 in pole caps	EMP-7 maximum field with 7 in to 2 in pole caps
Index 1	7.5 mm (0.30 in)	26.5 kOe (2.65 T)	31.3 kOe (3.13 T)
Index 2	12 mm (0.47 in)	24.1 kOe (2.41 T)	29.1 kOe (2.91 T)
Index 3	20 mm (0.79 in)	19.6 kOe (1.96 T)	25.5 kOe (2.55 T)
Index 4	25 mm (0.98 in)	16.9 kOe (1.69 T)	23.4 kOe (2.34 T)
Index 5	28 mm (1.10 in)	15.4 kOe (1.54 T)	22.3 kOe (2.23 T)
Index 6	50 mm (1.97 in)	9.1 kOe (0.91 T)	15.8 kOe (1.58 T)

### APPLIED FIELD STRENGTH WITH 2 IN POLE CAP REMOVED ( $\pm 1\%$ )

ExactGAP™ setting	Air gap	EMP-4 maximum field with 4 in bare pole	EMP-7 maximum field with 7 in to 4 in pole cap
Index 1	57.5 mm (2.26 in)	7.9 kOe (0.79 T)	13.6 kOe (1.36 T)
Index 2	62 mm (2.44 in)	7.3 kOe (0.73 T)	12.9 kOe (1.29 T)
Index 3	70 mm (2.76 in)	6.5 kOe (0.65 T)	11.8 kOe (1.18 T)
Index 4	75 mm (2.95 in)	6.1 kOe (0.61 T)	11.1 kOe (1.11 T)
Index 5	78 mm (3.07 in)	5.9 kOe (0.59 T)	10.8 kOe (1.08 T)
Index 6	100 mm (3.94 in)	4.6 kOe (0.46 T)	8.7 kOe (0.87 T)

### APPLIED FIELD STRENGTH WITH 4 IN and 2 IN POLE CAPS REMOVED ( $\pm 1\%$ )

ExactGAP™ setting	Air gap	EMP-7 maximum field with 7 in bare pole
Index 1	146.5 mm (5.77 in)	6.1 kOe (0.61 T)
Index 2	151 mm (5.94 in)	6.0 kOe (0.60 T)
Index 3	159 mm (6.26 in)	5.7 kOe (0.57 T)
Index 4	164 mm (6.46 in)	5.5 kOe (0.55 T)
Index 5		Not recommended for this pole cap configuration
Index 6		Not recommended for this pole cap configuration

\* ExactGap 1 or 2 maximum ramp rate = 5 kOe/s (0.5 T/s); ExactGap 3 maximum ramp rate = 4 kOe/s (0.4 T/s);

ExactGap 5 maximum ramp rate = 3 kOe/s (0.3 T/s)

For other air gaps, use the optional shim kit (MCS-EMP-SHIMS)

### FIELD MEASUREMENT

Field accuracy	1% of reading or $\pm 0.05\%$ of full scale
Field resolution	TBD
Max Field ramp rate	EMP-4: 10,000 Oe/s; EMP-7: 10,000 Oe/s
Closed loop field control stability:	TBD

### SAMPLE ROTATION

Setting resolution	TBD
Setting reproducibility	TBD
Rotation range	Continuous

### CERTIFICATIONS

CE	Yes
Application of Council directives:	2014/35/EU Low Voltage Directive; 2014/30/EU EMC Directive; 2011/65/EU RoHS Directive
Standard to which conformity is declared:	EN61010-1: 2010 Overvoltage Category II, Pollution Degree 2; EN61326-1: 2013 Class A, Controlled EM Environment; EN55011: 2009 Class A, Controlled EM Environment EN50581: 2012

### UTILITIES

Total system cooling water power dissipation (50 or 60 Hz)—contact us for available chillers  
EMP-4: 4250 W  
EMP-7: 13400 kW

Note: chiller power specifications listed are for 100% duty cycle. Many common applications will not require as much cooling power. Please consult Lake Shore for chiller recommendations for your specific applications.



# MeasureReady MCS modular characterization systems EMP electromagnet platforms

## MCS-EMP equipment

	EMP-4	EMP-7
<b>Electromagnet system controller</b>	F71 teslameter, PC and monitor, MeasureLINK™-MCS software, bipolar magnet power supply (see below) VT configuration adds Model 336 temperature controller 483 mm (19 in) console	
<b>Bipolar magnet power supply</b>	Model 643	Model 648
Maximum output	±35 V/±70 A (2,450 W)	±75 V/±135 A (9.1 kW nominal)
AC line input	200/208 VAC ±10%, 13 A/phase; 220/230 VAC ±10%, 12 A/phase; 380 VAC ±10%, 7 A/phase; 400/415 VAC ±10%, 6.5 A/phase at 50/60 Hz	200 VAC ±5%, 41 A/phase; 208 VAC ±5%, 40 A/phase; 220 VAC ±5%, 38 A/phase; 230 VAC ±5%, 37 A/phase; 380 VAC ±5%, 23 A/phase; 400 VAC ±5%, 21 A/phase; 415 VAC ±5%, 21 A/phase
Cooling water requirements	Tap water or closed cooling system (optional chiller available) +15 °C to +30 °C	
Flow rate	5.7 L (1.5 gal)/min minimum	7.6 L (2.0 gal)/min minimum
Pressure drop	10 kPa (1.5 psi) at 5.7 L (1.5 gal)/min minimum for power supply only	159 kPa (23 psi) at 7.6 L (2 gal)/min minimum for power supply and mandatory flow switch
<b>Electromagnet</b>	Model EM-4V	Model EM-7V
Pole diameter	100 mm (4 in)	180 mm (7 in)
Pole cap face diameter	50 mm (2 in)	50 mm (2 in)
Field homogeneity	±0.1% over 1 cm <sup>3</sup> (0.4 in <sup>3</sup> )	±0.1% over 1 cm <sup>3</sup> (0.4 in <sup>3</sup> )
Cooling water requirements	Tap water or closed cooling system (optional chiller available)	
Inlet temperature	15 to 25 °C (59 to 77 °F)	15 to 32 °C (59 to 89 °F)
Flow rate	7.6 L (2 gal)/min	11.4 L (3 gal)/min
Pressure drop	200 kPa (30 psi)	220 kPa (32 psi)
Water chiller capacity	2.5 kW (8,530 BTU)/h	5 kW (17,060 BTU)/h
Hall probe	FP-2X-250-TS15	

For additional magnet and power supply specifications, see the EM-4V and EM-7V Electromagnets and Electromagnet Power Supplies catalog

## MCS-EMP temperature options

	EMP-4	EMP-7
<b>Sample size</b>	Up to 10 mm × 10 mm × 3 mm standard, up to 50 mm diameter × 3 mm optional	
<b>CCR temperature</b>	15 K to 400 K with standard CCR, 15 K to 350 K with optical CCR	
<b>Oven temperature</b>	Room temperature to 1,273 K; at 773 K and ±1% rdg: maximum = 1 MΩ; at 1,273 K and ±1% rdg: maximum = 1 kΩ	

# MeasureReady MCS modular characterization systems

## EMP electromagnet platforms

### Ordering information

#### BASE PLATFORM

#### MeasureReady™ MCS-EMP base platform

Includes electromagnet with standard pole caps and electromagnet system controller with magnet power supply

*Specify AC power and CE mark in configurator*

**MCS-EMP-*W**X*-*Y*-*Z***



#### **W** = Magnet size

4 = 4 in (102 mm)

7 = 7 in (178 mm)

#### **X** = Teslameter

T = F71 (standard)

#### **Y** = Provision for temperature options (required if temperature options will be used)

N = None (standard)

V = Variable temperature kit installed (includes 336 temperature controller, GlideLOCK™ option mount, and cabling)

G = GlideLOCK™ option for physical mount only (no cabling supplied)

#### **Z** = Optical access

= None (standard)

O = 0.25 in access

For example, an MCS-EMP-7T-V-O is the base platform with a 7 in (102 mm) magnet, an F71 teslameter, variable temperature kit installed, and optical access added.

**MCS-EMP-HF** High field non-optical pole caps

**MCS-EMP-HF-O** High field optical access pole caps

*For additional or custom pole caps, please contact Lake Shore*

**ML-MCS-RENEW** MeasureLINK™-MCS annual subscription; first year included in EMP platform

# MeasureReady MCS modular characterization systems EMP electromagnet platforms

## Electronic measurement modules

**MCS-EMP-MM-FASTHALL** FastHall™ measurement module  
Includes MeasureReady™ M91-HR FastHall™ measurement controller, triaxial cables, scripts, and drivers; includes MCS-EMP-HP-BODY sample holder, see below; includes wall mount bracket; supports high & low resistance measurements; requires GlideLOCK™ configuration on base platform; gate bias measurement requires MeasureReady 155-DC source and user-supplied cable

## Sample options for electronic measurements

**MCS-EMP-HP-BODY** Sample body, room temperature, light tight with insert; includes wall mount bracket; requires GlideLOCK™ configuration on base platform

**MCS-EMP-HP-BODY-O** Sample body, room temperature, optical access with insert; includes wall mount bracket; requires GlideLOCK™ configuration on base platform

**MCS-EMP-HP-SI** Additional sample insert for room temperature body

**MCS-EMP-HP-SC-10-S** Sample card, 10 mm, solder pad, PT sensor

**MCS-EMP-HP-SC-10-P** Sample card, 10 mm, prober pin, PT sensor

**MCS-EMP-HP-SC-50-P** Sample card, 50 mm, prober pin (room temperature only)

**MCS-EMP-HP-FC** Field calibration card

**MCS-EMP-HP-ROTATE** Sample rotation for MCS-EMP-HP-SI with 10 mm cards

## Temperature options for electronic measurements

**MCS-EMP-OVEN** High temperature oven, includes MCS-EMP-OVEN-SI insert; includes wall mount bracket; requires variable temperature kit on base platform

**MCS-EMP-OVEN-SI** Spare oven insert (one included with MCS-EMP-OVEN)

**MCS-EMP-CCR** Closed cycle refrigerator; includes MCS-EMP-CCR-SI insert, stand for mounting (not GlideLOCK™ compatible); requires TPS-FRG or equivalent, LHe gas cylinder and regulator; requires variable temperature kit on base platform; must specify single phase (208/230, 200, 220 CE, 240 CE VAC) line voltage at order

**MCS-EMP-CCR-O** Closed cycle refrigerator, optical access; includes MCS-EMP-CCR-SI insert, stand for mounting (not GlideLOCK™ compatible); requires variable temperature kit on base platform; requires TPS-FRG or equivalent, LHe gas cylinder and regulator; must specify single phase (208/230, 200, 220 CE, 240 CE VAC) line voltage at order

**MCS-EMP-CCR-SI** Spare CCR insert (one included with MCS-EMP-CCR or MCS-EMP-CCR-O)

## MCS-EMP SYSTEM ACCESSORIES

**FP-2X-250-TS15**  
**TPS-FRG-100/120V** Replacement Hall probe for MCS-EMP with F71 teslameter  
Compact turbo pumping system; includes V-84 turbo pump (NW 40) with oil free dry scroll-backing pump, FRG-700 full range gauge, controller, and interface cable to USB port; includes Agilent 24 month warranty NOTE: requires SYS-TP-KIT

**TPS-FRG-220/240V-CE** Compact turbo pumping system; includes V-84 turbo pump (NW 40) with oil free dry scroll backing pump, FRG-700 full range gauge, controller, and interface cable to USB port; includes Agilent 24 month warranty NOTE: requires SYS-TP-KIT

**SYS-TP-KIT** Includes all components necessary to connect NW 40 turbo pumping system to the vacuum port of any Lake Shore system (except probe stations)

**1220-50** 50 L LN<sub>2</sub> Dewar with ½ in top withdraw port and 10 psi pressure relief valve

**E2M-110/120V** Two-stage rotary vacuum pump with mist filter; 110 to 120 VAC  
NOTE: requires SYS-RP-KIT

**E2M-220/240V** Two-stage rotary vacuum pump with mist filter; 220 to 240 VAC  
NOTE: requires SYS-RP-KIT

**MCS-EMP-SHIMS** Shim kit for electromagnet

## EMP MEASUREMENT MODULE TRAINING SERVICES

**HMS-TRAINING** Available (not required) for MCS-EMP-MM-FHALL measurement modules—2 days on-site operational training/verification; price includes travel time and expenses; remote Hall measurement training also available via Skype—contact Lake Shore for details

# MeasureReady MCS modular characterization systems

## EMP electromagnet platforms

### EM-V Series electromagnets

The EM-V Series electromagnets produce variable magnetic fields with a variety of air gap and pole cap configurations. They are ideal for applications including magneto-optical studies, magnetic hysteresis studies, in-line annealing, Hall effect studies, susceptibility measurements, spin magnetic resonance demonstrations, and biological studies.

### Specifications

#### EM-4V typical field uniformity

Magnet configuration		Uniformity over 1 cm <sup>3</sup>	1% cylindrical volume	
Pole cap mm (in)	Air gap mm (in)		Diameter mm (in)	Length mm (in)
102 (4.0)	51 (2.0)	±0.15%	18 (0.7)	51 (2.0)
102 (4.0)	25 (1.0)	±0.05%	64 (2.5)	25 (1.0)
76 (3.0)	25 (1.0)	±0.06%	46 (1.8)	25 (1.0)
51 (2.0)	25 (1.0)	±0.35%	18 (0.7)	25 (1.0)
51 (2.0)	13 (0.5)	±0.16%	36 (1.4)	13 (0.5)

#### EM-7V typical field uniformity

Magnet configuration		Uniformity over 1 cm <sup>3</sup>	1% cylindrical volume	
Pole cap mm (in)	Air gap mm (in)		Diameter mm (in)	Length mm (in)
51 (2.0)	16 (0.6)	±0.11%	28 (1.1)	16 (0.6)
51 (2.0)	25 (1.0)	±0.33%	10 (0.4)	25 (1.0)
102 (4.0)	16 (0.6)	±0.03%	74 (2.9)	16 (0.6)
102 (4.0)	25 (1.0)	±0.03%	66 (2.6)	25 (1.0)
102 (4.0)	38 (1.5)	±0.05%	48 (1.9)	38 (1.5)
102 (4.0)	51 (2.0)	±0.08%	23 (0.9)	51 (2.0)

NOTE: The third column gives uniformity over one cubic centimeter volume centered in the magnet gap. The last two columns give the cylindrical volume within which the magnetic field deviates by less than 1% from the central field. The cylindrical volume is coaxial with the magnet poles and centered in the gap.

	EM-4V	EM-7V
Air gaps	With no pole caps With 2 in pole caps	57.5, 62, 70, 75, 78, and 100 mm 7.5, 12, 20, 25, 28, and 50 mm
Coil resistance, nominal	0.25 Ω per coil (0.5 Ω total wired in series)	1.00 Ω per coil (0.5 Ω total wired in parallel)
Coil resistance, cold	0.23 Ω per coil (0.46 Ω total wired in series)	0.92 Ω per coil (0.46 Ω total wired in parallel)
Coil resistance, maximum	0.27 Ω per coil (0.54 Ω total wired in series)	1.08 Ω per coil (0.54 Ω total wired in parallel)
Integrated pole diameter	100 mm (4 in)	178 mm (7 in)
Available pole cap diameters	50 mm (2 in)	100 mm (4 in) and 50 mm (2 in)
Cooling water	Tap water or closed cooling system	
Water flow rate	7.6 L/min (2 gal/min)	11.4 L/min (3 gal/min)
Pressure drop	200 kPa (30 psi)	220 kPa (32 psi)
Water chiller cooling capacity	2.5 kW (8,530 BTU/h)	5.0 kW (17,060 BTU/h)
Water inlet temperature	15 °C to 25 °C (59 °F to 77 °F)	
Coil over temperature limit	45 °C (113 °F)	
Coil spacing, nominal	121 mm (4.75 in)	178 mm (7 in)
Coil size-width, nominal	121 mm (4.75 in)	132 mm (5.2 in)
Coil size-diameter, nominal	311 mm (12.25 in)	445 mm (17.5 in)
Current (maximum continuous operating)	±70 A	±135 A
Voltage, nominal	±35 V (approximately 38 V at maximum coil temperature)	±70 V (approximately 38 V at maximum coil temperature)
Continuous input power, nominal	2.5 kVA (2.65 kVA at max temperature)	9.45 kVA (10.125 kVA at max temperature)
Suggested power supply	Lake Shore Model 643	Lake Shore Model 648
<b>Size</b>		
Height	77 cm (30.3 in)	52.7 cm (20.8 in)
Width	78.7 cm (31 in)	78.7 cm (31 in)
Depth	88.9 cm (35 in)	88.9 cm (35 in)
Weight	201.9 kg (445 lb)	635 kg (1400 lb)
Shipping weight	215.5 kg (475 lb)	660 kg (1500 lb)
Shipping dimensions	0.97 m × 0.58 m × 0.56 m (38 in × 23 in × 22 in)	0.86 m × 1.22 m × 1.19 m (34 in × 48 in × 47 in)

# MeasureReady MCS modular characterization systems

## EMP electromagnet platforms

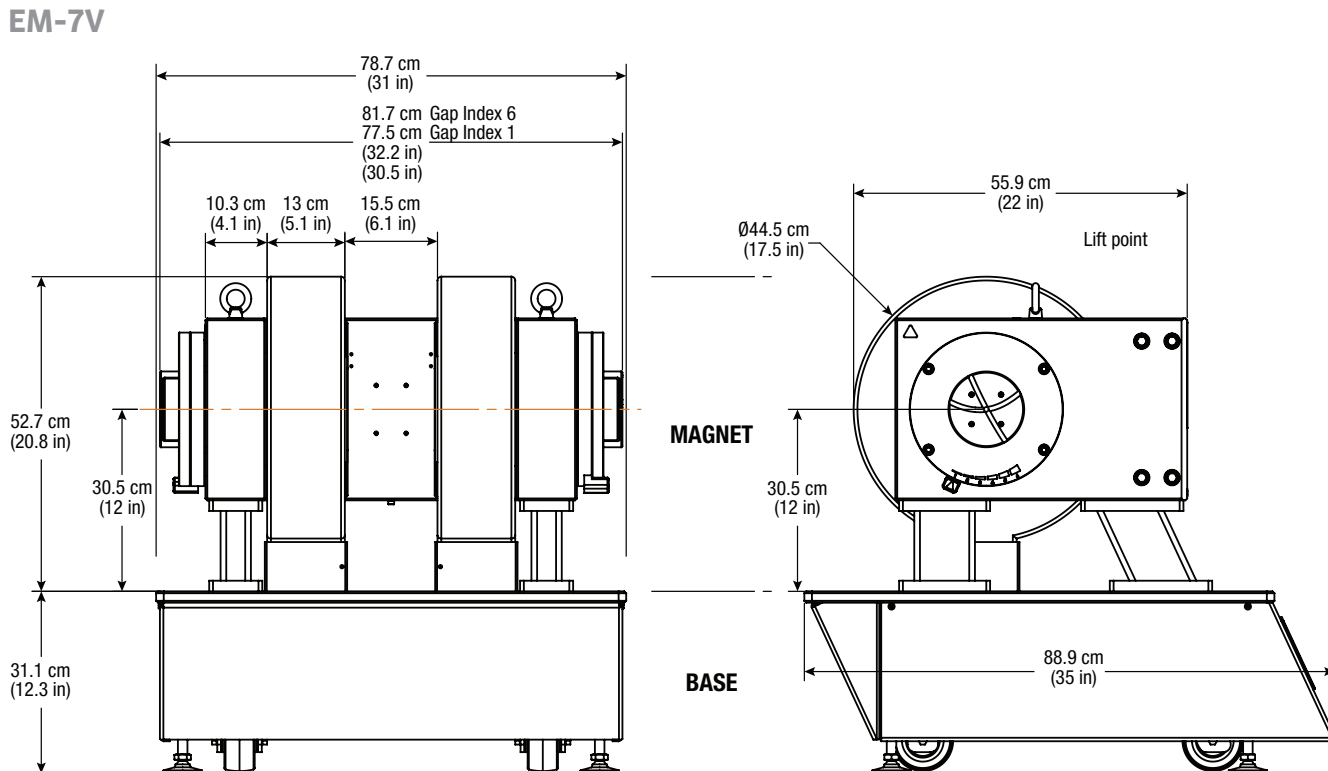
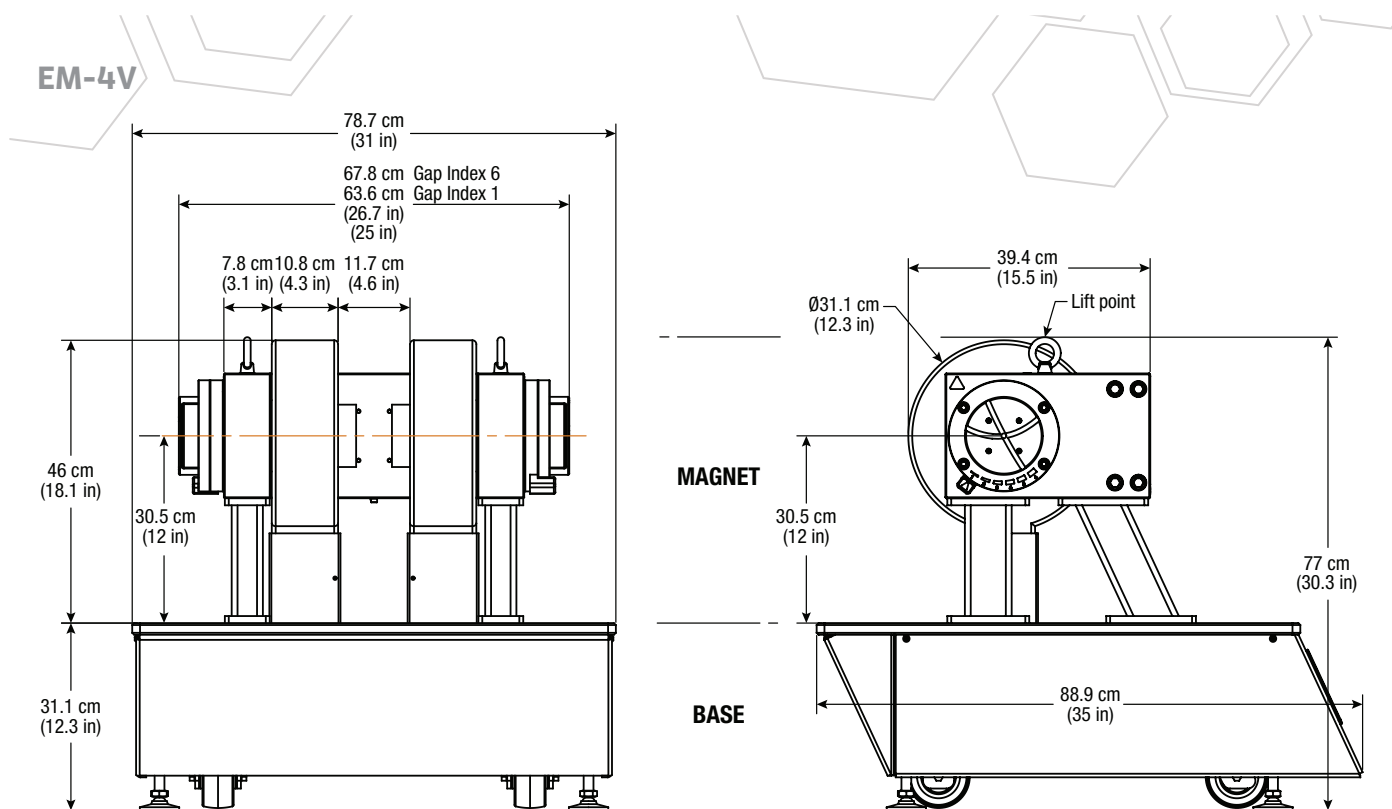

# MeasureReady MCS modular characterization systems

## EMP electromagnet platforms

### EM-V Series field plots

EM-7V no pole caps field plot

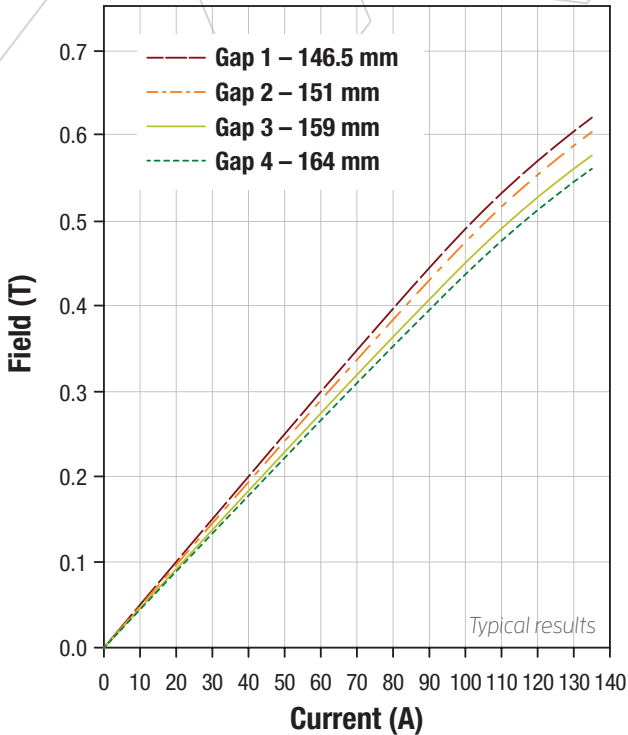

EM-7V 100 mm (4 in) pole caps field plot

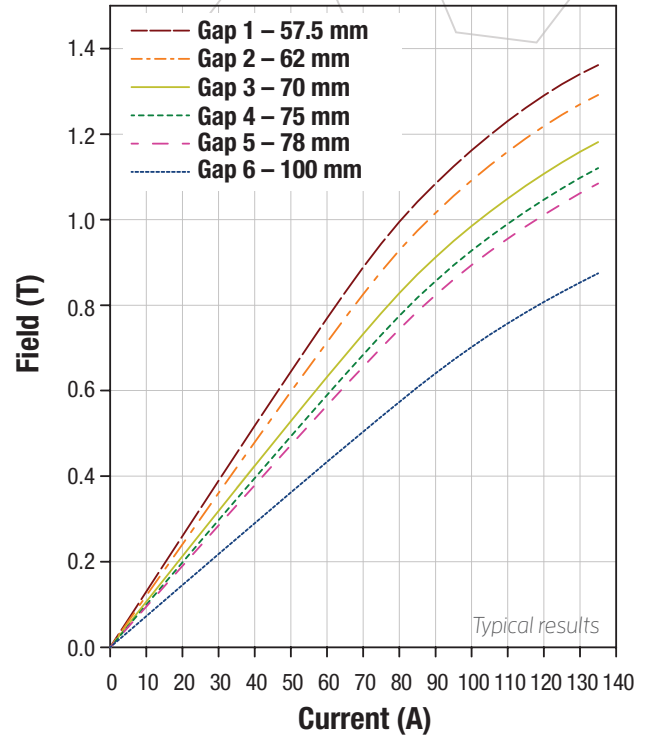

EM-7V 50 mm (2 in) pole caps field plot

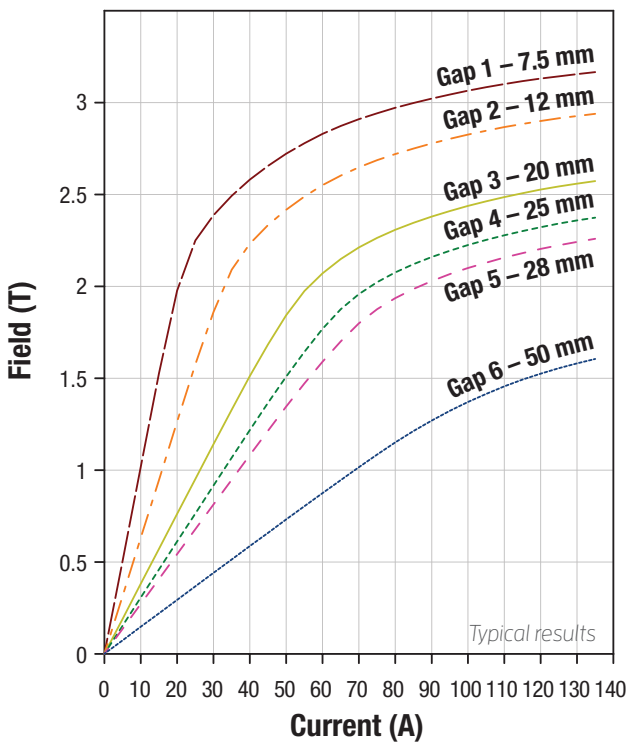

EM-7V remanent field

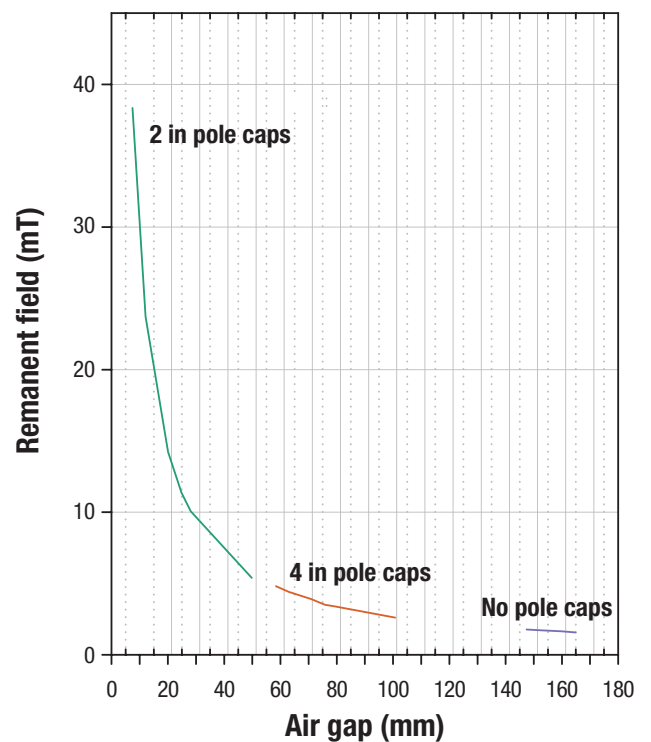

# MeasureReady MCS modular characterization systems

## EMP electromagnet platforms

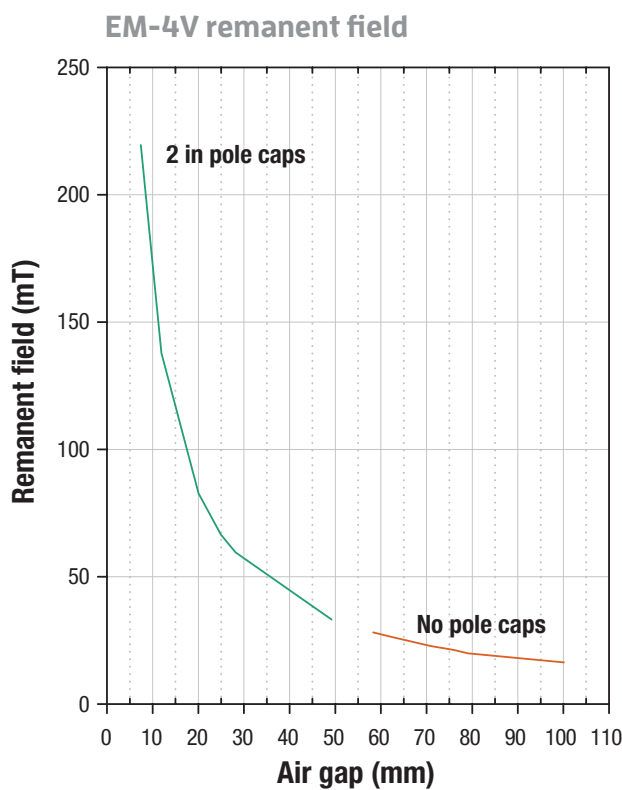
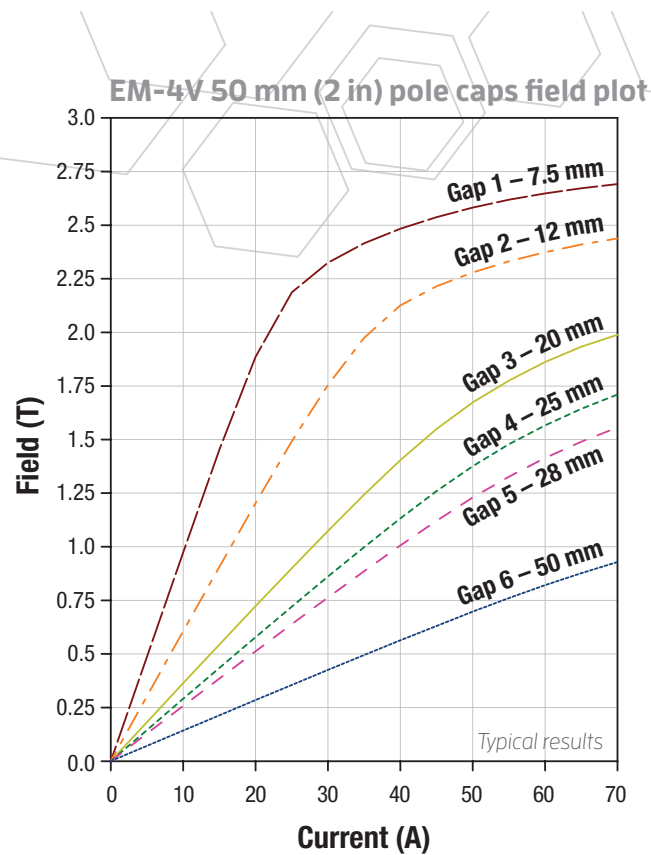
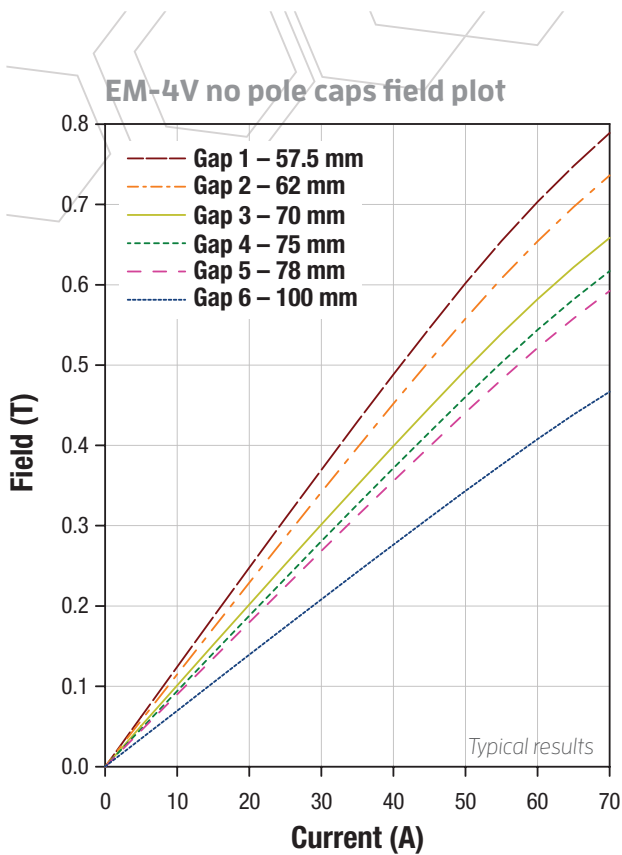

## Ordering information

### Electromagnets

- EM-4V** 4 in electromagnet with base and standard 4 in to 2 in pole caps; includes water manifold and cables
- EM-4V-0** 4 in electromagnet with base and optical access 4 in to 2 in pole caps; includes water manifold and cables
- EM-7V** 7 in electromagnet with base and standard 4 in to 2 in pole caps; includes water manifold and cables
- EM-7V-0** 7 in electromagnet with base and optical access 4 in to 2 in pole caps; includes water manifold and cables

### Power supplies

- 648** 7 in electromagnet power supply; specify AC power in configurator
- 643** 4 in electromagnet power supply; specify AC power in configurator

### Accessories

- MCS-EMP-HF** High field non-optical pole caps
- MCS-EMP-HF-0** High field optical access pole caps

*For additional or custom pole caps, please contact Lake Shore*

**Please see the EM-V catalog for more details and other accessory ordering information**

---

# MeasureReady MCS modular characterization systems

## EMP electromagnet platforms

