

Teslameters and FP series Hall probes



F71 Multi-Axis Teslameter

F41 Single-Axis Teslameter

FP Series Hall Probes

Teslameters and FP series Hall probes

F41 and F71 Teslameters

F71 Multi-axis teslameter

F41 Single-axis teslameter

Perfect for measuring magnetic fields in a wide variety of applications, the new Lake Shore Cryotronics F71 and F41 teslameters with FP Series probes offer a new level of precision, convenience, and dependability.



Features

- TruZero™ technology eliminates the need to re-zero probes
- Touchscreen interface is instantly familiar to smartphone owners
- TiltView™ display makes the instruments easy to use whether bench- or rack-mounted
- Smaller, ultra-thin Hall sensor active areas for improved accuracy
- Multiple probe types to suit your application
- 3-year standard warranty



Measure confidently



TruZero™ technology eliminates errors that plague magnetic field measurements, allowing you to take measurements without probe zeroing worries



New 2Dex™ Hall sensor probes take more accurate measurements with smaller active areas and better linearity performance than previous generation sensors



Temperature and field built in to produce field readings with great accuracy over a wide range of operating conditions

Operate easily



Uncluttered touchscreen using icons, gestures, and navigation techniques familiar to any smartphone user



The TiltView™ display is comfortable to see and operate, providing an improved touchscreen experience



Take accurate measurements sooner with quality low-temperature coefficient electronics that eliminate warm-up times



Lightweight and durable handheld probes for quick and convenient measurements



Swap out probes fast and hassle-free with the new unified quick-release connector with built-in calibration data

Integrate conveniently



Rack-mountable, with the ability to place other similarly sized instruments next to the teslameter



Fixture-mountable probes with machined aluminum handles and alignment features for easy attachment

Both teslameters offer modern wired and wireless connectivity choices for seamless system integration, including:



Industry standard SCPI communication library available along with LabVIEW™ and IVI drivers.

Teslameters and FP series Hall probes

Measure confidently

Smaller active areas

FP Series probes feature 2Dex™ Hall sensors with significantly smaller active areas than in previous generation products. This results in improved spatial resolution and reduced signal averaging, useful when measuring fields close to a source where field gradients can be extreme.

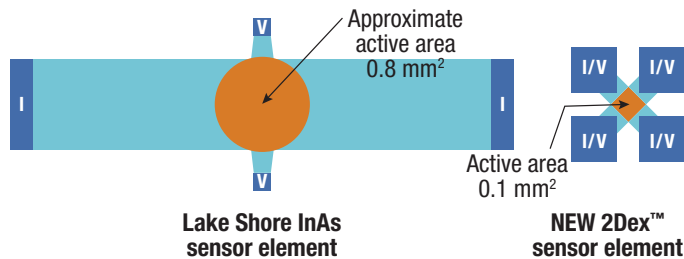

Temperature compensation

Hall effect sensors have several characteristics that vary with temperature, resulting in Hall voltage levels that can change slightly with temperature changes. The 2Dex™ sensors used in FP Series probes are inherently stable with temperature, however, this can be improved further with active temperature compensation.

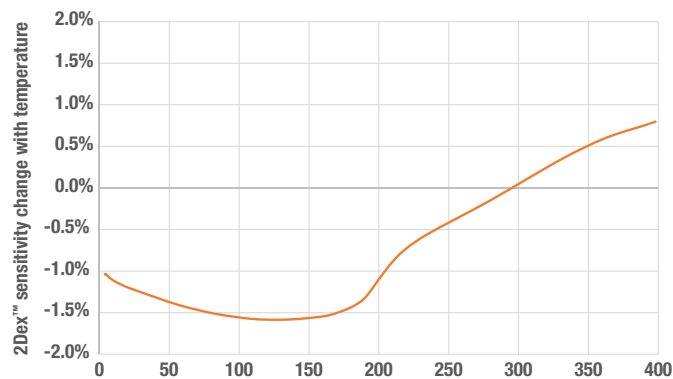

An integrated temperature sensor at the tip of every probe relays temperature data to the teslameter. These readings are used to determine temperature offsets and compensate for them over the standard workplace ambient temperature ranges.

Better 3-axis measurements

2Dex™ 3-axis magnetic sensors have been designed to maximize orthogonality between x, y, and z sensor elements, resulting in more accurate vector magnitude measurements when field direction is unknown or changing.

Operate easily

As easy to use as your smartphone

Made for the way you work today, the F71 and F41 teslameters feature an uncluttered touch display with a unique TiltView™ screen, presenting a natural and engaging user interface.



With no confusing buttons or long learning curves, these teslameters are simple and intuitive to operate. You will quickly recognize the icons, gestures, and menu styles that follow familiar smartphone technology standards.

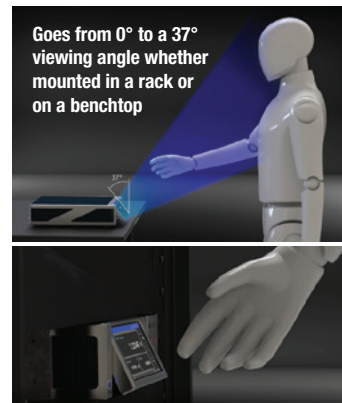

The large 5-inch capacitive touchscreen allows measurements to be displayed in clear, easily distinguishable fonts, making it possible to easily read in situations when your instrumentation is located some distance from where you are taking measurements.

Viewing angle is a critical parameter when interacting with a touchscreen.

Registering accurate presses can be difficult if the viewer is not aligned correctly with the screen.

TiltView™ allows the viewer to manually adjust the viewing angle of the screen, resulting in a better view and increased accuracy when interacting with the touchscreen.

The tilt mechanism uses the perfect amount of stiffness to allow movement when desired, but stays in place when pressing and swiping on the screen.

Teslameters and FP series Hall probes

Never zero your probe again

Offset errors in typical Hall probes occur for several reasons:

- Thermoelectric effects, which cause the offset to change with temperature.
- Imperfect contact placement geometry on the sensor, which creates so-called “misalignment voltage” errors that are harder to correct for.

These errors result in probe “drift,” impacting measurement repeatability.

Typical Hall probes must be regularly placed in a **zero-gauss chamber** to zero out offsets that develop over time.



TruZero™ technology

Lake Shore’s TruZero™ technology eliminates the need to perform these frequent zeroing operations, saving time and ensuring that measurements are always accurate.

This multi-part technology is accomplished through multiple mechanisms:

- 1 2Dex™ Hall effect sensors used in FP Series probes are highly symmetrical and uniform, resulting of inherently low zero-field offset voltages.
- 2 Special insulation used in the cable for optimum dielectric performance.
- 3 The advanced sensor excitation “spinning” technique progressively switches between different measurement configurations.
- 4 An onboard algorithm combines the sequential Hall voltage readings in a way that eliminates any offsets due to misalignment and thermoelectric effects. This method also reduces flicker noise, meaning that readings are both more accurate and more precise.

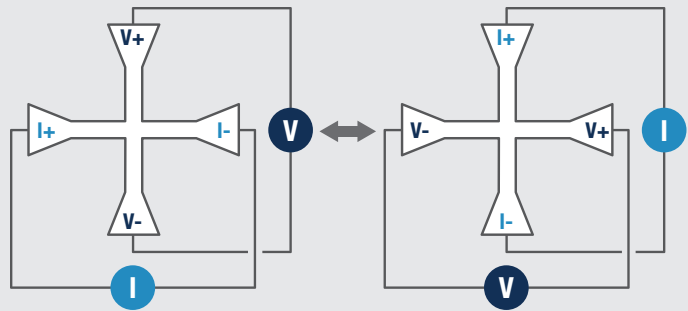

This means there is never a need to “zero” the probe before making a measurement. TruZero™ technology allows fast, worry-free, and always accurate measurements.

Note: periodic recalibration of probe and teslameter is still required to maintain an accurate conversion from Hall voltage to a field value. Not all errors can be removed completely with TruZero. Very small residual errors, much smaller than Earth field, may remain.

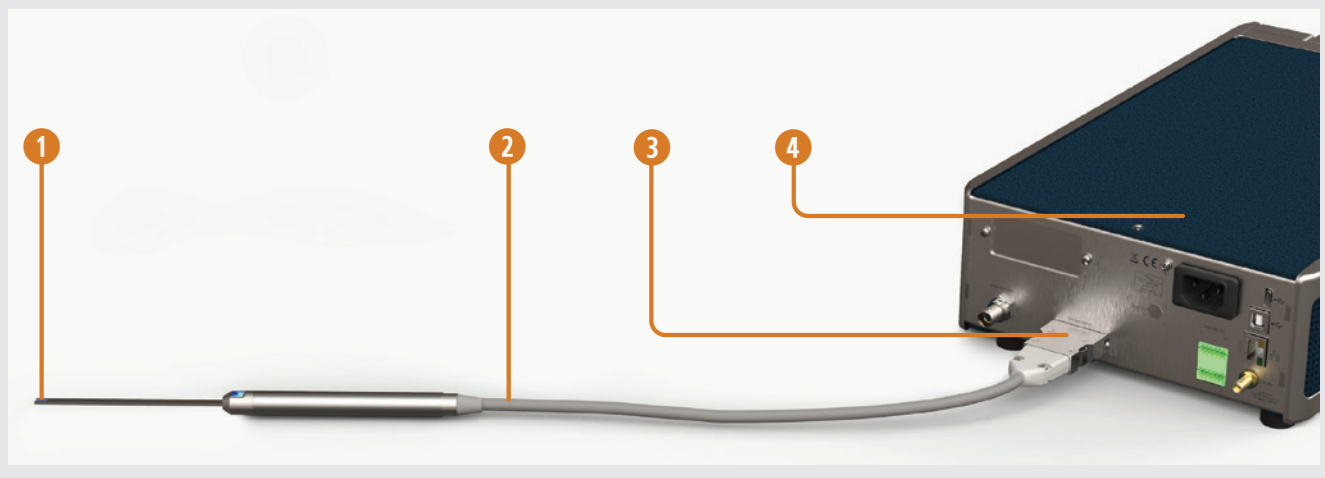

Teslameters and FP series Hall probes

TruZero™ demonstration

An experiment was conducted to observe the qualitative benefit delivered by TruZero technology.

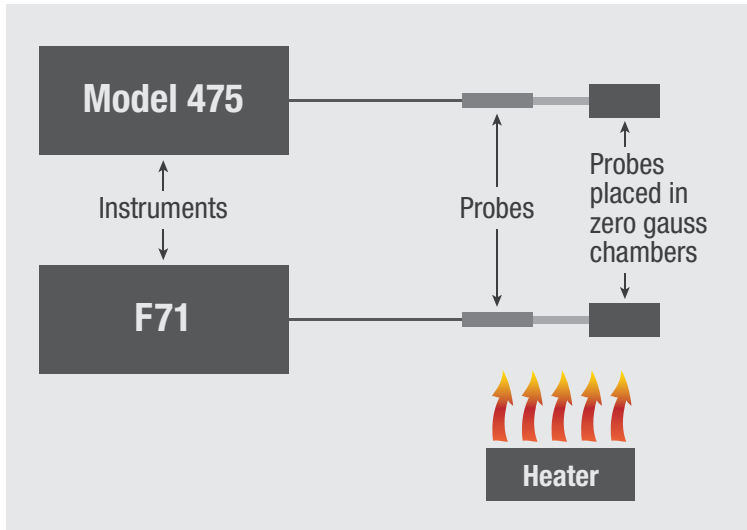

Experiment setup

- Model 475 and F71 placed in a temperature controlled room.
- Probes placed in zero gauss chambers where magnetic field is practically zero.
- 475 zeroed at the beginning of the experiment.
- Temperature cycled over multiple hours.

Outcomes

F71

- Very slight zero-offset drift with temperature
- No apparent drift with time
- Measurement resolution measured in nT

475

- More significant zero-offset drift with temperature
- Noticeable drift over several hours
- Measurement resolution measured in μT

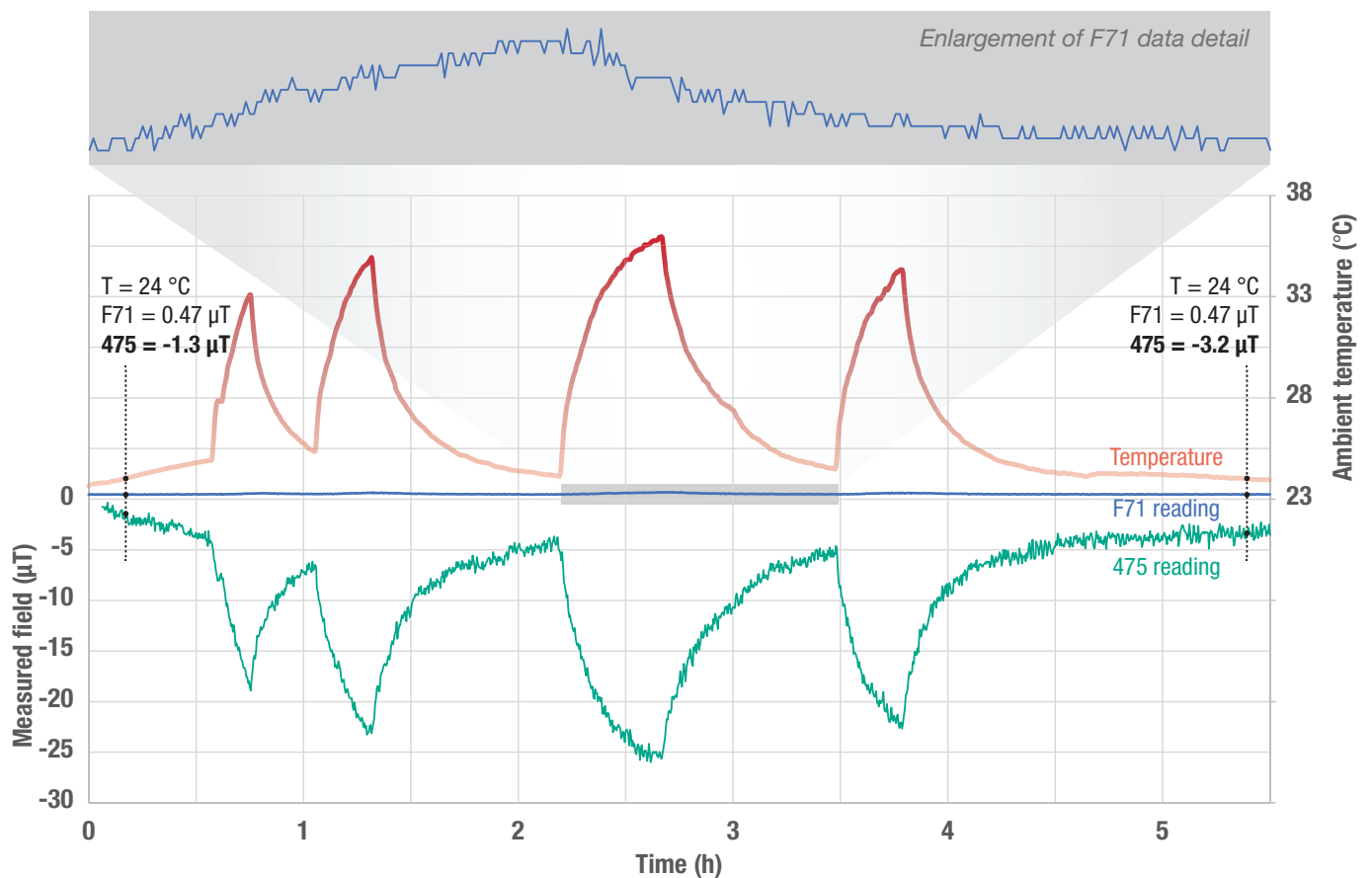

Teslameters and FP series Hall probes

Start taking measurements sooner

Lengthy warm-up times of 30 minutes or more are recommended for many teslameters and gaussmeters in order to stabilize internal temperatures.

The F71 and F41 teslameters use high-stability components with low temperature coefficients, eliminating warm-up time. Accurate readings can be taken instantly with these teslameters, removing one more variable to consider when taking field measurements.

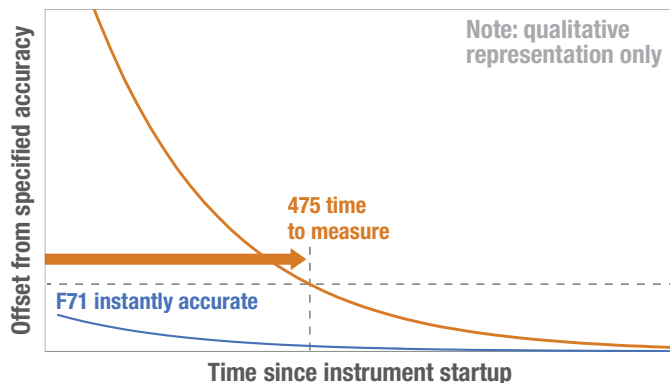

A single connector you can use without looking

The F71 multi-axis teslameter reaches its full potential when reading a 3-axis probe, delivering full vector field measurements. Connecting a probe like this should be quick and easy, which lead us to select our new probe connector.

- *Just one connector per probe*—previous implementations used separate connectors for each axis, requiring the user to pay special attention when connecting each of the 3 axes to their appropriate inputs. The new connector is used on both single and multi-axis probes, making it easier than ever to switch between probes.

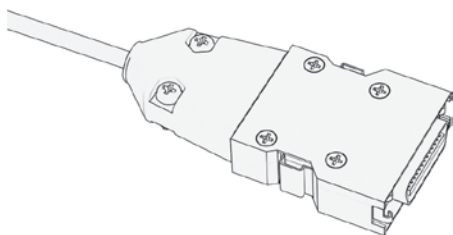

- *New latching mechanism*—allows quick and easy connection of a probe to the teslameter. The latches hold the connector securely in place without requiring thumb screws. When swapping probes, the quick-release mechanism allows you to switch probes reliably in just seconds.

Integrate conveniently

System integration

The F41 and F71 teslameter use the same 2U half-rack chassis as other Lake Shore XIP instruments, with several mounting options for standard 19-inch racks:

- Single Lake Shore XIP instrument with adjacent blank panel
- Two adjacent Lake Shore XIP instruments
- Single Lake Shore instrument next to 3rd party 2U ½ rack instrument with common mounting screws

Fixture-friendly probes

Specifically designed for scenarios where fixturing the probe is required to achieve repeatable measurements.



- Machined aluminum mounting block for a solid non-deforming surface
- Locating pin holes allow for precise alignment of the probe
- Easily held in place with just two screws
- Drawings and CAD models publicly available, making integration with your hardware quick and easy, while minimizing the risk of design error.

Probe customizations welcomed

If your application requires something different, Lake Shore may be able to design a probe to fit your exact needs. FP Series probes are all manufactured in our Ohio facility with engineering staff onsite ready to support your application. Contact your local sales representative today to start the conversation.

Teslameters and FP series Hall probes

Teslameter specifications

Input

Input overview

	F41 single-axis	F71 multi-axis
Number of measurement inputs	1	3
Number of physical connectors	1	
Connector type	25-pin mini D-sub	

Electronic resolution

Measured noise across a short, useful for determining teslameter performance isolated from external sources of noise and offsets

	Typical RMS noise (1 s averaged shorted input readings)	Equivalent field values (using typical 2Dex sensitivity of 104 mV/T at 2 mA drive current)
35 T (350 kG) range	40 nV	0.4 μ T (4 mG)
3.5 T (35 kG) range	40 nV	0.4 μ T (4 mG)
350 mT (3.5 kG) range	5 nV	0.05 μ T (500 μ G)
35 mT (350 G) range	2 nV	0.02 μ T (200 μ G)

Electronic accuracy

Calibrated accuracy of the teslameter without a probe connected; environment ± 5 °C of instrument calibration temperature

35 T (350 kG) range	$\pm 0.15\%$ of reading, $\pm 0.00001\%$ of range
3.5 T (35 kG) range	$\pm 0.05\%$ of reading, $\pm 0.00001\%$ of range
350 mT (3.5 kG) range	$\pm 0.05\%$ of reading, $\pm 0.0001\%$ of range
35 mT (350 G) range	$\pm 0.06\%$ of reading, $\pm 0.001\%$ of range

Software features

Available measurement readings

	Frequency range (within specified accuracy)	DC component	AC RMS	AC peak- values	Frequency
DC	DC only	YES	—	—	—
AC	DC to 60 Hz	YES	YES	YES	YES
High frequency	20 Hz to 10 kHz*	—	YES	YES	YES

*May be limited by probe

Maximum hold

	DC measurement mode	AC measurement mode	High frequency mode
F41 single-axis	Field reading	RMS reading	RMS reading
F71 multi-axis	Magnitude readings	RMS reading of magnitude	RMS reading of magnitude

Maximum value Closest value to $+\infty$

Minimum value Closest value to $-\infty$

Max hold reset Reset max and min values at the same time or separately

Relative value

	DC measurement mode	AC measurement mode	High frequency mode
F41 single-axis	Field reading	RMS reading	RMS reading
F71 multi-axis	Magnitude reading	RMS reading of magnitude	RMS reading of magnitude

Relative functions Baseline (directly enter relative offset value)
Tare (set offset to current field value)
Reset (set offset to zero)

DC field measurement performance

Measurement resolution

Typical RMS measurement noise that would be present when measuring a fixed field (teslameter and probe both contribute to measured noise, a realistic representation of measurement performance)

	Averaging window			
	10 ms	200 ms (default)	1 s	10 s
35 T (350 kG) range	300 μ T (3000 mG)	70 μ T (700 mG)	30 μ T (300 mG)	10 μ T (100 mG)
3.5 T (35 kG) range	6 μ T (60 mG)	1.2 μ T (12 mG)	0.6 μ T (6 mG)	0.17 μ T (1.7 mG)
350 mT (3.5 kG) range	0.7 μ T (7 mG)	0.16 μ T (1.6 mG)	0.07 μ T (0.7 mG)	0.03 μ T (0.3 mG)
35 mT (350 G) range	0.5 μ T (5 mG)	0.12 μ T (1.2 mG)	0.05 μ T (0.5 mG)	0.02 μ T (0.2 mG)

Measurement accuracy

Accuracy of the reported field measurement when a standard probe is used to measure a magnetic field at instrument calibration temperature ± 5 °C. Dictated by uncertainty values for Hall probe calibration stations. Does not include TruZero residual offset for the teslameter that will also be present, but may be significantly smaller than the probe measurement accuracy.

	Single-axis	3-axis magnitude
35 T (350 kG) range*	$\pm 1\%$ of rdg	$\pm 2\%$ of rdg
3.5 T (35 kG) range*	$\pm 0.15\%$ of rdg	$\pm 0.25\%$ of rdg
350 mT (3.5 kG) range	$\pm 0.15\%$ of rdg	$\pm 0.25\%$ of rdg
35 mT (350 G) range	$\pm 0.15\%$ of rdg	$\pm 0.25\%$ of rdg

*Each probe calibrated to 2.5 T minimum. Sensors characterized to 18 T. Calibration data for each probe extrapolated to 35 T. Accuracy specifications are expected to hold for fields exceeding 2.5 T, but cannot be guaranteed.

TruZero™ residual offset

Remaining detectable measurement offset (observed at zero field and expected to be present at higher fields as well)

	Within ± 5 °C of probe calibration temperature	Typical temperature coefficient beyond ± 5 °C of probe calibration temperature
Single-axis	± 3.5 μ T	± 0.3 μ T/°C
3-axis magnitude	± 7 μ T	± 0.6 μ T/°C

Teslameters and FP series Hall probes

AC field measurement performance

AC mode

Best for low frequency AC fields where higher accuracy or the inclusion of DC offset is required

AC mode cut-off frequency 625 Hz (-3 dB)
60 Hz (-0.2%)

Teslameter frequency response: AC mode

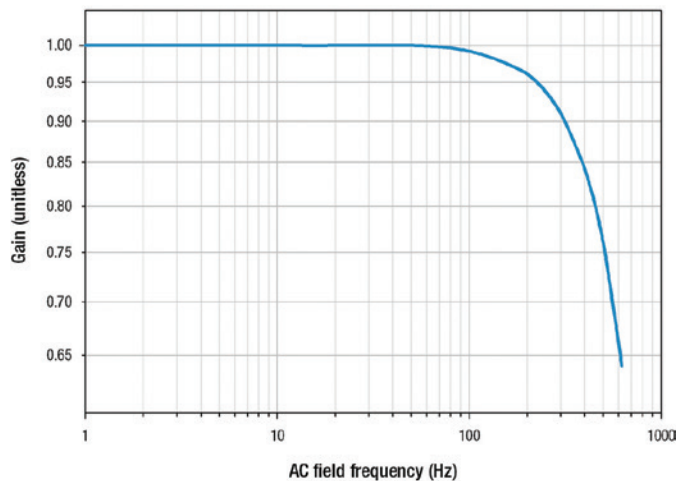

Measurement accuracy

Accuracy of the reported field measurement when a standard probe is used to measure a magnetic field at instrument calibration temperature $\pm 5^\circ\text{C}$. Dictated by uncertainty values for Hall probe calibration stations.

	Single-axis	3-axis magnitude
AC mode RMS accuracy	$\pm 0.25\%$ of reading $\pm 0.05\%$ of range	$\pm 0.5\%$ of reading $\pm 0.1\%$ of range
AC mode peak to peak accuracy	$\pm 0.55\%$ of reading $\pm 0.2\%$ of range	Reading not present on instrument

High frequency mode

High frequency mode passband

1.7 Hz to 80 kHz (-3 dB point)
20 Hz to 7 kHz (0.2%)

Teslameter frequency response: HF mode

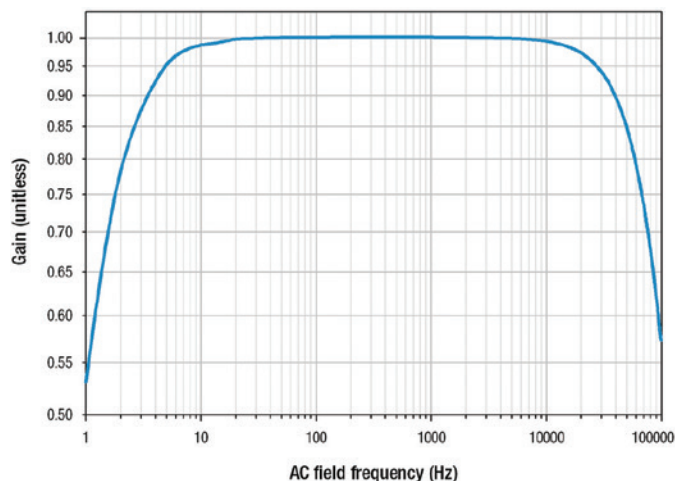

Measurement accuracy

Accuracy of the reported field measurement when a standard probe is used to measure a magnetic field at instrument calibration temperature $\pm 5^\circ\text{C}$. Dictated by uncertainty values for Hall probe calibration stations.

	Single-axis	3-axis magnitude
HF mode RMS accuracy	$\pm 0.5\%$ of reading $\pm 0.5\%$ of range	$\pm 1\%$ of reading $\pm 1\%$ of range
HF mode peak to peak accuracy	$\pm 2\%$ of reading $\pm 2\%$ of range	Reading not present on instrument

Teslameters and FP series Hall probes

Analog output

Analog output raw signal accuracy	±1% of amplified AC Hall voltage value ±50 mV
Raw analog output voltage range	±15 V rails, ±12.5 V maximum during overload

Digital I/O

Inputs

Number of independent inputs	2
Input isolation	Optical
Maximum low-level input voltage	1 V
Minimum high-level input voltage	4 V
Safe input voltage range	-5 V to 35 V

Outputs

Number of relays	2
Relay type	Solid state
Digital output relay maximum current	2 A
Digital output relay maximum voltage	35 V

Front panel

Display update rate	5 rdg/s
Display	5 in capacitive touch, color 800 × 480 with LED backlight

Interface

USB host

Type	USB 3.0, mass storage class (MSC) device
Function	Firmware updates, flash drive support
Location	Rear panel
Connector	C-type USB connector

USB device

Type	USB 2.0
Function	Emulates a standard RS-232 serial port
Protocol	Standard commands for programmable instruments (SCPI)
Baud rate	115,200
Connector	B-type USB connector
Software support	LabVIEW™ and IVI.NET drivers (see www.lakeshore.com)

Ethernet

Function	TCP/IP command and control, mobile app (in development)
App layer protocol	Standard commands for programmable instruments (SCPI)
Connector	RJ-45
Speed	1 Gb/s
Software support	LabVIEW™ and IVI.NET drivers (see www.lakeshore.com)

Wi-Fi

Type	802.11 b/g/n
Function	TCP/IP command and control, mobile app (in development)
App layer protocol	Standard commands for programmable instruments (SCPI)
Antenna	External, coaxial
Software support	LabVIEW™ and IVI.NET drivers (see www.lakeshore.com)

General

Operating conditions	Rated accuracy: 18 °C to 28 °C, <70% relative humidity non-condensing Reduced accuracy: -20°C to 70 °C, <90% relative humidity non-condensing
Warm-up time	0 min at rated operating conditions
Instrument maximum field exposure	10 mT (100 G) DC, 1 mT (10 G) RMS; exposure to any significant amount of field has the potential to cause reading offsets
Power requirement	100 V to 240 V (universal input), 50 to 60 Hz, 30 VA
Size	217 mm W × 87 mm H × 317 mm D (8.5 in × 3.4 in × 14.5 in), half rack
Weight	3.2 kg (7 lb)
Approval	CE mark
Wireless approvals	FCC: TFB-TIW11-01, IC: 5969A-TIW1101, Giteki: G209-J00157

Teslameters and FP series Hall probes

What happened to “gaussmeter?”

In 1992 Lake Shore made a splash in the magnetic measurement space with its first gaussmeter, the Model 450 single-axis gaussmeter.

In the decades since, Lake Shore has released 9 other gaussmeter models, ranging from battery-powered handhelds through to full-rack multi-axis units. The word “gaussmeter” has been used to describe them all.

As units of magnetic flux density (B), gauss and tesla have long been used to characterize magnetic forces and are related to one another by a factor of 10,000:

	Gauss	Tesla
System of units	cgs (centimeter-gram-second)	SI (meter-kilogram-second)
Definition	1 Mx/cm ²	1 Wb/m ²
Equivalent	0.0001 T (100 μT)	10,000 G (10 kG)

The preference to use gauss stems from its relationship with magnetic field strength (H), which in cgs units is the oersted and has the extremely simple relationship of 1 gauss = 1 oersted in free space, which was much easier to work with than the 4π component in the SI conversion process.

However, cgs units have since been deprecated by SI units, with tesla now being the official worldwide unit for magnetic flux density. In the US, this was signed into law in 1998 and has since been codified by NIST Special Publication 1038.

Given Lake Shore’s dedication to advancing science, we felt it was time to shed the product name that ties us to an old measurement scheme and move to one that reflects the state of modern measurements. The confusing part may come from us leaving our previous generation of products as gaussmeters. Over time these instruments, along with their names will be retired, but until that happens we plan to continue referring to them with the names they were originally given.

We encourage everyone to begin transitioning to the use of “teslameter” to describe these products. However, we understand that old habits can be difficult to break, so we promise we can stay friends even if you use gaussmeter and teslameter interchangeably. Because in the end, it doesn’t matter what you call them, as long as they are a pleasure to use and allow you to take the measurements you need.

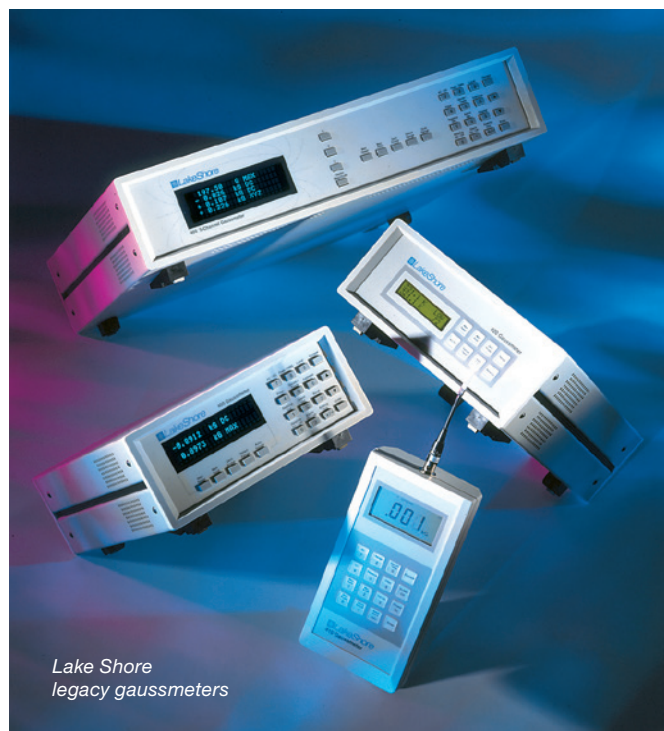

Ordering information

F41/F71 teslameters

F41	F41 single-axis teslameter
F71	F71 multi-axis teslameter

Accessories

CAL-F41-CERT	F41 teslameter recalibration with certificate
CAL-F41-DATA	F41 teslameter recalibration with certificate and data
CAL-F71-CERT	F71 teslameter recalibration with certificate
CAL-F71-DATA	F71 teslameter recalibration with certificate and data

Teslameters and FP series Hall probes

Collaborator Program

The new Lake Shore teslameters are amazing instruments, but we're not done yet. Our firmware development team will continue to add and improve software features, but we want your help. The Collaborator Program allows you to provide input and help us prioritize future development. Engage with us as often as you like, or just enjoy the free updates as features are added.

What you need to know about the program:

- Teslameter hardware is complete, with future optional updates applying to software and firmware only. This means that at the end of the program, all Collaborator Program teslameters will have equivalent functionality to new teslameters.
- A discount of 15% is applied to the price of both teslameter models for the duration of the program.
- Downloading software updates requires a Wi-Fi or Ethernet connection to the internet.
- Product feedback can be provided on <http://forums.lakeshore.com>, with development updates being posted there as well.



Not ready to purchase one of the new teslameters, but interested in following along with development? Sign up to receive notifications at www.lakeshore.com/teslameters.

Give us your opinions on the priority and implementation of features such as:

- Cryogenic operating mode
- Closed loop field control (via purchased option card)
- High-speed data capture (100/s)
- Additional programming libraries
- Pulse capture (targeting magnetizer applications)
- Signal filtering
- Data logging
- Onboard chart recorder
- Quality control features such as pass/fail and alarms
- Audible peak field detector
- DIY calibrations
- Mobile application support

Note: this is not an extensive list. Features will be added, removed and reprioritized with input from the community.

Teslameters and FP series Hall probes

FP Series Hall probes

Features

- Wide field range—suited for everything from earth-field to the world's strongest electromagnets
- 2Dex™ sensors with tiny active area of just 0.1 mm² for more precise measurements
- Temperature and linearity (field) compensation are built-in
- Versatile handle and stem options to suit numerous applications
- Ease of use features such as active area and polarity indicators
- Application-specific probe customization available



The FP Series probes make it easier than ever to integrate magnetic field measurement into your system. Take advantage of probes and sensors that really fit your application for optimum measurement results.

Lake Shore offers probes for every need, including 3-axis (vector), transverse, and axial models available in both handheld and fixture-mountable versions. Special cryogenic versions are also available.

If your application is unique, Lake Shore may be able to design a probe to fit your exact needs. FP Series probes are all manufactured in our Ohio facility with engineering staff on site ready to support your application. Contact your local sales representative today to start the conversation.

Teslameters and FP series Hall probes

FP Series probe availability

Transverse

Stem type	Stem material	Stem size	Form factor	Stock probes highlighted in yellow				Part number
				Stem Lengths (cm)				
Standard	Aluminum	1.55 × 4.57 mm	Handheld	5	15	30	—	FP-2X-250-TSXX
			Mountable	5	15	30	—	FP-2X-250-TSXXM
Flexible-thin	PCB	1.14 × 3.53 mm	Handheld	—	15	—	—	FP-2X-250-TF15
			Mountable	—	15	—	—	FP-2X-250-TF15M
Cryogenic <i>coming soon</i>	Stainless steel	4.75 mm diameter	Handheld	—	—	30	150	FP-2X-250-TCXXX

Axial

Stem type	Stem material	Stem size	Form factor	Stem Lengths (cm)				Part number
				Stem Lengths (cm)				
Standard	Aluminum	2 mm diameter	Handheld	5	15	30	—	FP-2X-250-ASXX
			Mountable	5	15	30	—	FP-2X-250-ASXXM
Cryogenic <i>coming soon</i>	Stainless steel	4.75 mm diameter	Handheld	—	—	30	150	FP-2X-250-ACXXX

3-axis

Stem type	Stem material	Stem size	Form factor	Stem Lengths (cm)				Part number
				Stem Lengths (cm)				
Standard	Aluminum	4 × 4 mm	Handheld	5	15	30	—	FP-2X-250-ZSXX
			Mountable	5	15	30	—	FP-2X-250-ZSXXM

The mountable handle has locating pin holes for precise and repeatable probe alignment.

CAD files for the mounting fixture template are available free in the Downloads section of the teslameter pages on our website.

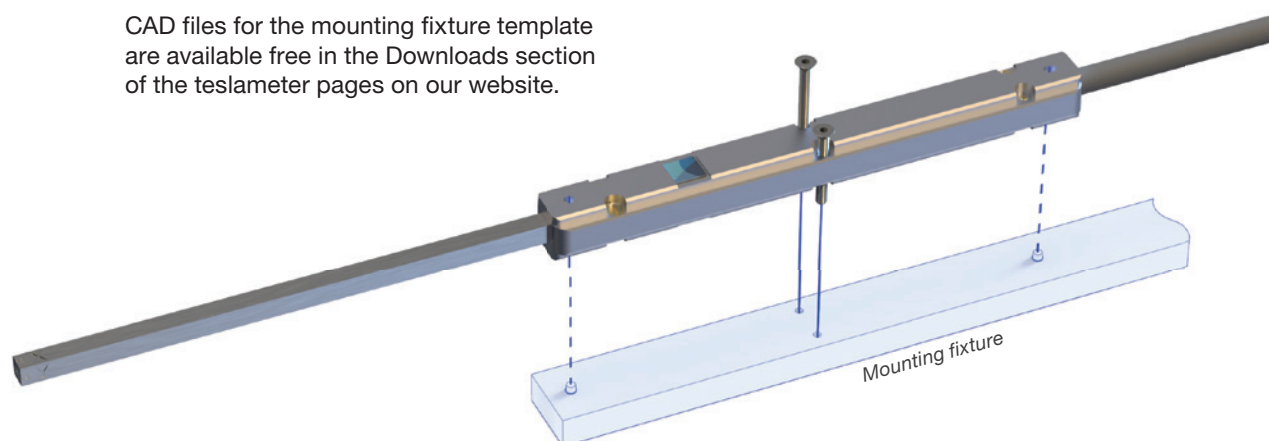

Teslameters and FP series Hall probes

Probe configuration options

Customize your probe using the range of available options to match your application.

FP-aa-bbb-cdee(f)(-gg)

Sensor

2X-250	2Dex™
--------	-------

Orientation

Z	3-axis
T	Transverse (single-axis)
A	Axial (single-axis)

Stem type

S	Standard
F	Flexible-thin
C	Cryogenic

Stem length

05	5 cm (2 in)
15	15 cm (6 in)
30	30 cm (12 in)
150	150 cm (60 in)

Special handle (optional)

	Handheld (default)
M	Mountable

Additional cable length (optional)

	2 m (6 ft) (default)
6	6 m (20 ft)
15	15 m (50 ft)

Sensor

2X-250	2Dex™
--------	-------

2Dex™ sensors are currently the only sensor types currently available with FP Series probes. These are the first probes to feature 2Dex sensors which offer a great balance of sensitivity, linearity, stability and ruggedness. These sensors set the new standard for the majority of field measurement applications.

Orientation

Hall sensors are inherently directional, so the anticipated field direction will guide the selection of probe orientation.

Z	3-axis
---	--------

Multiple sensors are placed to measure three orthogonal field vectors, allowing the measurement of both the overall field value and direction. This is particularly useful in several scenarios:

- Complex fields where the field direction is not known or changing over time
- Quick handheld measurements
- Field mapping of a volume

The three individual sensors don't occupy the exact same location, meaning the three separate measurements are for slightly different positions in space. This results in the specification of an active volume, as opposed to an active area for single-axis probe variants. These probes can be identified by their square stem cross-section.

3-axis probes are only available with a standard stem up to 30 cm in length.

T	Transverse (single-axis)
---	--------------------------

The sensor is positioned to measure fields running perpendicularly through the probe stem. This is most useful for measuring fields inside magnet gaps. These probes are easily identified by their flattened rectangular stem.

A	Axial (single-axis)
---	---------------------

The sensor is placed very near to the tip of the probe and aligned to measure fields normal to the tip of the probe. This orientation is necessary when measuring inside solenoids, and can be useful for measuring fields at magnet poles due to the increased ease of alignment and fine adjustment.

Axial probes are not offered with a flexible-thin stem.

Teslameters and FP series Hall probes

Stem type

The sensor/s are housed in stem types suited for various applications. Where possible, active area locations are marked on the stems.

S Standard

The general-purpose stem options offer an excellent balance of size and strength. Constructed from extruded and precision machined aluminum, these stems will be the superior choice in most situations.

F Flexible-thin

This stem type is currently only available as a transverse orientation option at a fixed stem length. The surrounding aluminum stem of the standard probe is removed, exposing the PCB and sensor element. This results in a somewhat flexible stem that is also thinner than the standard offering, making it the best probe for measuring in very thin magnet gaps. It is possible to snap the PCB stem of this probe with excessive bending, so this should be minimized to prolong the life of the probe.

This stem also features a helpful ruler printed directly on the PCB. Useful in determining just how far the probe has been inserted into the magnet gap.

C Cryogenic (coming soon)

Ultra-low temperature applications require a more drastic overhaul of the probe stem:

- Non-magnetic stainless-steel alloy minimizes heat leak, while providing strength
- Greater stem lengths offered as standard to reach into the cryogenic environment
- Vented at the tip to allow cryogenics to escape safely
- Cryogenic 2Dex™ sensors used in place of standard solution

Due to the increased sensor size used in these probes, 3-axis probes with very small active volumes are not possible. Contact us if you have an application that requires multi-axis cryogenic measurements to discuss options.

Stem length

FP Series probes come in various lengths to suit your application.

	5 cm (~2 in)	15 cm (~6 in)	30 cm (~12 in)	150 cm (~60 in)
	05	15	30	150
Standard	■	■	■	
Flexible		■		
Cryogenic			■	■

If your application requires a non-standard stem solution, please contact us to discuss options.

Teslameters and FP series Hall probes

Special handle (optional)

Both handle options include polarity indicators when ordered with a transverse orientation, making it easy to quickly determine whether a magnet polarity has been switched, or if the probe is just being held incorrectly.

Handheld (default)

The default handle configuration is designed to be a comfortable and functional handheld solution with an anodized aluminum grip for a solid and long-lasting grip surface.

M Mountable

In situations where probe fixturing is required to achieve repeatable measurements, the mountable form factor features a flat machined aluminum surface. It also includes locating pinholes for precise probe alignment and is easily held in place with just two screws.

Publicly available drawings and CAD models for this handle will make integration with your hardware quick and easy while minimizing the risk of a design error. These handles are available with standard and flexible stem choices.

Cryogenic probes are not available with a mountable stem.

Additional cable length (optional)

2 m (6 ft)	6 m (15 ft)	15 m (50 ft)
	6	15

The probe cable and connector have also received close attention to optimize performance and usability. The shielded cable was selected to be as thin and light as possible, while using a special insulation that is both recyclable and forms a part of the TruZero™ technology that allows the probes to operate without needing to zero.

The connector makes use of the compact Micro-D standard to support all connections required for a 3-axis probe in a reasonably sized package. Both single and multi-axis probes use this connector, so there is no need to pay special

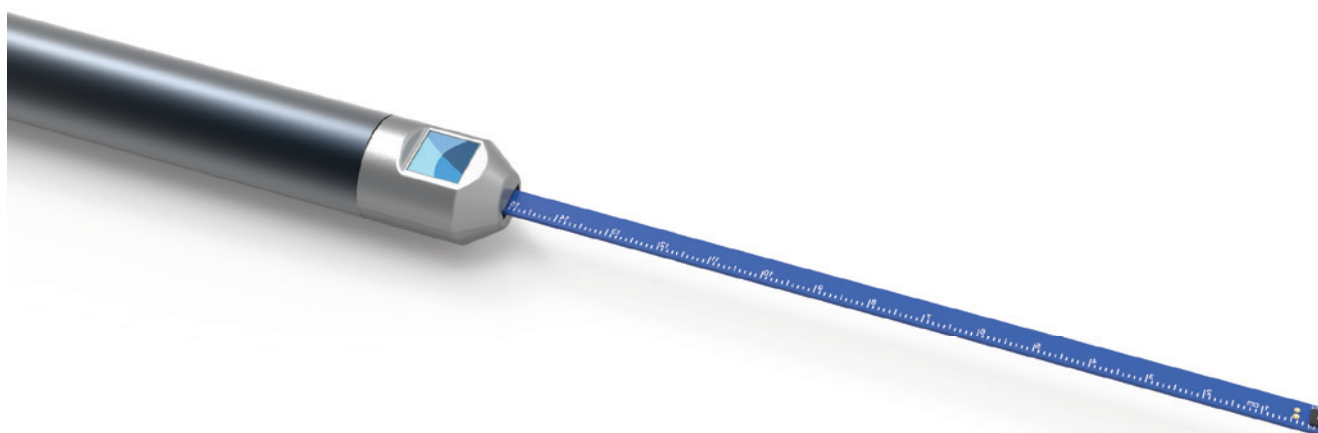

Teslameters and FP series Hall probes

FP Series probe specifications

Sensor type

	Sensor	Description	Active area
2X-250	2Dex™ 2X-250	2Dex™ standard sensor	0.1 mm²

Temperature compensation

	Built-in thermistor	Temperature range
Standard	Yes	0 °C to 90 °C
Flexible-thin	Yes	0 °C to 90 °C
Cryogenic	No	1 K to 400 K using external temperature data

Stem material

	3-axis	Transverse	Axial
Standard	Anodized aluminum tube with a 4 mm square cross section	Anodized aluminum tube with a 1.55 mm maximum thickness by 4.57 ± 0.13 mm rectangular cross section	Anodized aluminum tube with a 2 mm diameter circular cross section
Flexible-thin	NA	FR-4 PCB 1.14 mm maximum thickness by 3.53 mm	NA
Cryogenic	NA	316 stainless steel tube with 4.75 +0.15/-0.11 mm diameter circular cross section	316 stainless steel tube with 4.75 +0.15/-0.11 mm diameter circular cross section

Stem length: Distance from tip of sensor to beginning of handle

Stem operating temperature range

	3-axis	Transverse	Axial
Standard	0 °C to 90 °C	0 °C to 90 °C	0 °C to 90 °C
Flexible-thin	NA	0 °C to 90 °C	NA
Cryogenic	NA	1.5 K to 363 K	1.5 K to 363 K

Handle

	Handheld (default)	Mountable
Length, including strain relief	138 mm	110 mm
Diameter	13 mm	NA
Thickness	NA	10 mm
Width	NA	12 mm
Material	ABS/polycarbonate blend with anodized aluminum grip	Machined aluminum with brass screws. Mountable to fixture using customer supplied M2 screws with 3.8 mm diameter socket head and 2 mm diameter alignment pins
Operating temperature range	0 °C to 80 °C	0 °C to 80 °C

Cable

	Single-axis	3-axis
Diameter	4 mm (0.17 in)	5.2 mm (0.21 in)
Bend radius	40 mm (1.57 in)	52 mm (2.05 in)
Operating temperature range	-40 °C to 80 °C	
Conductors	4 twisted-pair	14 twisted-pair
Cable shield	100%-coverage foil	100%-coverage foil
Cable insulation	Modified polyphenylene ether	
Connector	26-pin Mini-D with quick-release latch	

Axial probe (ASXX) typical frequency response

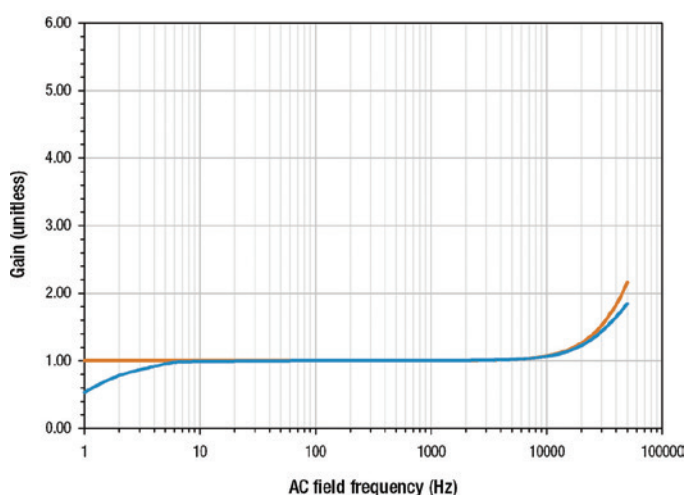

— Probe only
— Teslameter and probe combined (HF mode)

Transverse probe (TSXX) typical frequency response

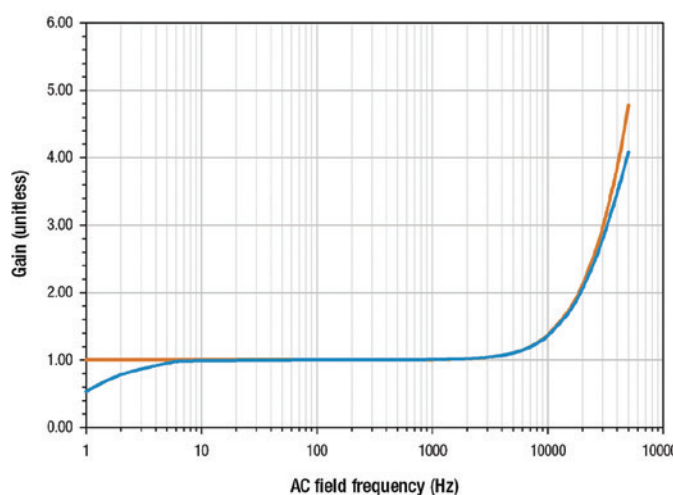

Teslameters and FP series Hall probes

Probe active areas

Axial probe active area

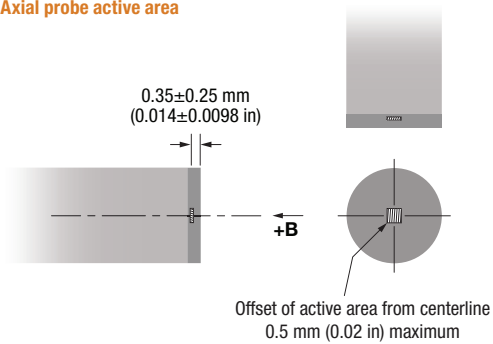

Transverse probe active area

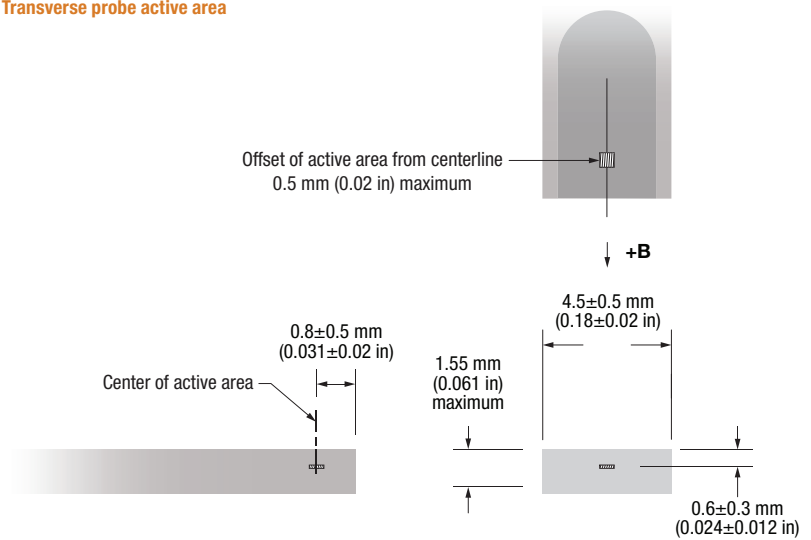

3-axis probe active area

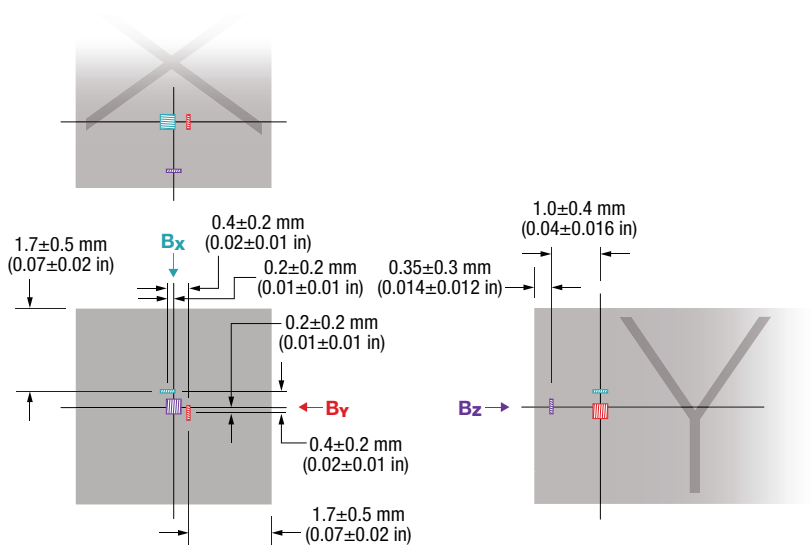

Teslameters and FP series Hall probes



Teslameters and FP series Hall probes

Copyright © Lake Shore Cryotronics, Inc. All rights reserved. Specifications are subject to change.

Lake Shore Cryotronics, the Lake Shore logo, the square graph logomark, and Cernox are registered trademarks of Lake Shore Cryotronics, Inc.

All other trade names referenced are the service marks, trademarks, or registered trademarks of their respective companies.

050319

Questions? Answers?

Visit <http://forums.lakeshore.com/>
and become part of the conversation!

