

TECHNICAL GUIDE

The Beginner's Guide to Cryostats and Cryocoolers

Lake Shore Cryotronics

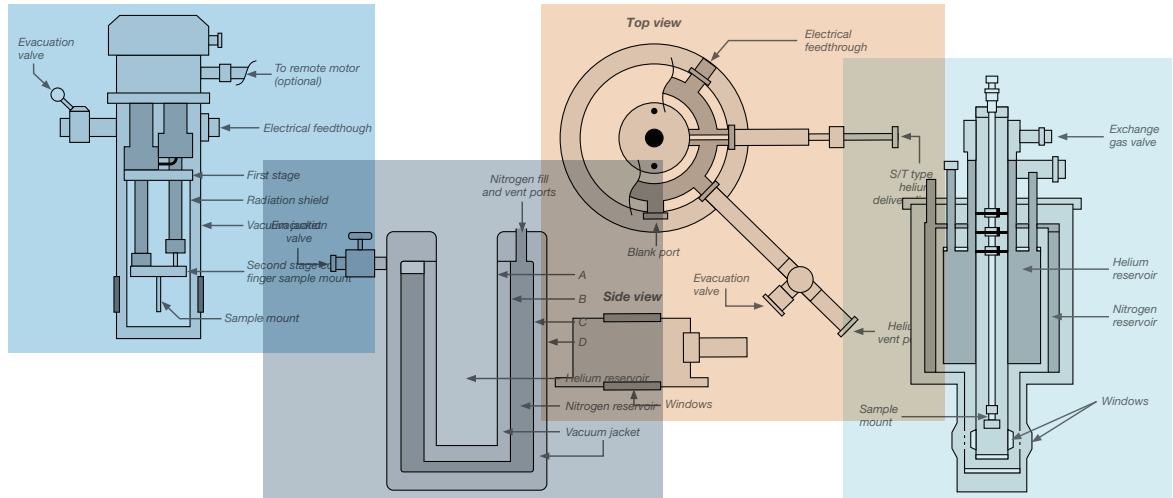

Preface

This work is for scientists, students, and laboratory personnel with little or no cryogenics experience. It concentrates primarily on cryogenic systems that are commercially available for operation between 1.5 K and 300 K (room temperature). Many excellent references are at the end of this booklet for users who want to design and build their own equipment or are interested in a more detailed analysis of cryogenic systems.

The first section discusses the vacuum requirements of laboratory Dewars and variable temperature cryostats. Then comes a section on liquid helium and liquid nitrogen Dewars and another section on variable temperature cryostats. The following section concentrates on superconducting magnets combined with variable temperature cryostats for laboratory experiments requiring relatively large magnetic fields.

Section 5 describes closed-cycle refrigerator cryostats that require no liquid cryogens, and the last section concentrates on experimental techniques, thermometry, and automatic temperature control. This last section also includes a few tables that help estimate heat loads on the cold stage and the attached sample. More detailed information and experimental data are available from the references listed at the end of this document.

The figures throughout sections 2 to 6 show a variety of Dewar and cryostat designs based primarily on our experience at Lake Shore Cryotronics. These designs have evolved over 40 years and represent a typical cross-section of laboratory units that can be used for a wide variety of experiments. Many other configurations with differing designs are available but were excluded for the sake of brevity. However, the designs discussed in this booklet should address most standard experimental requirements for work at low temperatures.

The Beginner's Guide to Cryostats and Cryocoolers

Table of contents

1. Vacuum requirements	3
2. Liquid helium and nitrogen Dewars	4
A. Welded Dewars	4
B. Detachable-tail Dewars	7
C. Tail extensions	7
1. Immersion tails	7
2. Tails for sample in vacuum	8
3. Variable-temperature cryostats	9
A. Thermal impedance cryostats	9
B. Exchange gas cryostats	10
1. Exchange gas insert for open-neck Dewars	10
2. Exchange gas inserts for detachable-tail Dewars	11
I. Sample in exchange gas	11
II. Sample in vacuum	12
C. Continuous flow cryostats	12
1. Flow cryostats with detachable-tail Dewars	12
2. Flow cryostat inserts for open-neck Dewars	14
3. Continuous transfer cryostats	14
I. Sample in vacuum	15
II. Sample in vapor	15
III. Special microscopy systems	16
4. Closed-cycle refrigerator systems	16
A. Cold finger cryostats	18
B. Exchange gas cryostats	19
C. Vibration-isolated cryostats	20
5. Experimental techniques and data	21
A. Cooldown of helium cryostats and samples	21
B. Thermometry and temperature control	22
1. Sensor installation	22
I. Silicon diodes	22
II. Gallium arsenide diodes	23
III. Platinum resistors	23
IV. Cernox resistors	23
V. Ruthenium oxide resistors	23
VI. Germanium resistors	23
VII. Carbon-glass resistors	24
VIII. Rhodium iron resistors	24
IX. Thermocouple temperature sensors	24
2. Automatic temperature controllers	24
C. Useful cryogenic data and references	26
1. Thermal conductivities and conductive heat loads	26
2. Radiational heat loads	26
3. Thermal expansion	27
4. Experimental data for cooldown	27

Figures

2.1 Open-neck liquid nitrogen Dewar	5
2.2 Open-neck nitrogen shield liquid helium Dewar	5
2.3 Superinsulated liquid helium belly Dewar	6
2.4 Nitrogen shielded low-loss helium Dewar	6
2.5 Immersion tubular tail Dewar	7
2.6 Cold finger/sample in vacuum	9
3.1 Thermal impedance cryostat	10
3.2 Exchange gas insert	11
3.3 Optical exchange gas cryostat	12
3.4 Sample in vacuum exchange gas cryostat	12
3.5 Continuous transfer cold finger cryostat	15
3.6 Continuous transfer sample in vapor cryostat	16
3.7 Continuous transfer microscopy cryostat	16
4.1 Closed-cycle refrigerator cryostat	18
4.2 Pulse tube cooler cryostat	19
4.3 Exchange gas refrigerator cryostat	20
4.4 Vibration-isolated sample in exchange gas	20
4.5 Vibration-isolated G-M cooler	21
5.1 Average thermal conductivity in W/cm·K (Ref. 1, Ch. VII, Ref. 4)	27
5.2 Experimental values of emissivities (Ref. 7)	27
5.3 Thermal expansion data (Ref. 2, Appendix B and Ref. 8, Ch. 3)	27
5.4 Experimental data for helium and nitrogen (Ref. 9, Ch. 8)	27
5.5 Densities of SS, Cu, and Al (Ref. 10, Appendix H)	27
5.6 Enthalpy of SS, Cu, and Al (Ref. 9, Ch. 8)	27
5.7 Amount of helium to cool common metals (Ref. 9, Ch. 3)	28

The Beginner's Guide to Cryostats and Cryocoolers

1. Vacuum requirements

A liquid helium or nitrogen Dewar usually consists of one or more reservoirs containing the cryogen. The cryogen reservoirs are surrounded by an evacuated jacket to reduce (or eliminate) the conductive heat load due to any gases inside this jacket. This conduction causes moisture condensation around the outside of the Dewar and, more importantly, results in an unacceptable heat load on the cryogen reservoir(s). Therefore, most Dewars and transfer lines are supplied with a valve on the outer jacket to evacuate this space.

Liquid nitrogen shielded, liquid helium Dewars usually have two interconnected vacuum jackets surrounding the helium and the nitrogen reservoir. In such Dewars, the liquid helium reservoir is surrounded by a liquid nitrogen reservoir to reduce the radiational heat load into the helium reservoir. Because this heat load is proportional to the fourth power of the absolute temperature, a liquid nitrogen reservoir at 77 K radiates significantly less than an equivalent surface at 300 K (room temperature). Other liquid helium Dewars and transfer lines are supplied with multi-layer insulation (MLI) surrounding the cryogen reservoir (or inner line) and only one evacuated jacket. MLI or floating radiation shields reduce the radiational heat load into the liquid helium space, as the escaping helium vapor cools the inner layers in an adequately designed Dewar. Liquid nitrogen Dewars contain only one vacuum jacket and may also include MLI for reducing the radiational heat load from room temperature on the nitrogen reservoir.

The pressure in the vacuum jacket of Dewars and transfer lines should be reduced to at least 10^{-4} Torr, and preferably one or two orders of magnitude lower. At room temperature, a 10^{-4} Torr pressure results in a mean-free path of approximately 100 cm (40 in; Ref. 1, Ch. VII), much larger than the typical separation between the outer and inner walls of most research Dewars. This region of molecular flow is where the dominant type of collision process is between the molecules and the walls of the vacuum jacket(s). The heat load in a typical cryostat (from 77 K to 4.2 K) due to helium gas at a pressure of 10^{-5} Torr is a few milliwatts (Ref. 2, Ch. 4). It is, therefore, critical to reduce the pressure inside the vacuum jacket to the 10^{-5} or 10^{-6} Torr region.

Various pumping stations can obtain pressures of 10^{-5} to 10^{-6} Torr. The most commonly used stations consist of a turbomolecular pump backed by a rotary pump. A diffusion pump, backed by a rotary pump, may also be used, with a liquid nitrogen cold trap to prevent oil vapors from back-streaming into the vacuum jacket. A 76 mm (3 in) diffusion pump is generally sufficient for most laboratory Dewars and cryostats. Turbomolecular pumping stations have a slight advantage over diffusion pumping stations because the

turbomolecular pump can be activated simultaneously with the backing rotary pump. On the other hand, a diffusion pump should not be turned on until the backup rotary pump has reduced the pressure to about 5×10^{-2} Torr to prevent the diffusion pump oil's oxidization. Lower-speed (40 to 60 L/s) turbomolecular pumps are now available at the same price as the 76 mm (3 in) diffusion pumps and are quite adequate for use with smaller laboratory-type cryostats. An oil-free turbomolecular pumping system backed by an oil-free diaphragm pump can be used for critical situations where oil vapors should be avoided entirely. These pumping stations typically have lower pumping speeds and ultimate vacuum levels.

Furthermore, the diaphragm pumps are not as rugged as the standard mechanical pumps and require replacement after a couple of years of use.

Rotary pumps are occasionally used (in line with a cold trap) to reduce the pressure to 10^{-2} Torr (single stage) or 10^{-3} Torr (good double stage). Such pressures are not preferred for liquid nitrogen Dewars or cryostats that operate between 77 K and 300 K. However, they occasionally perform satisfactorily with liquid helium Dewars if the Dewar evacuation valve is sealed just before the liquid helium is transferred into the Dewar. This is because the liquid helium reservoir cryopumps the Dewar vacuum and results in a pressure of 10^{-6} Torr, which is quite adequate. If this setup is used with certain variable temperature cryostats, once the cryostat is heated above 80 K, outgassing occurs and can result in poor performance due to the deteriorating vacuum level.

Most pumps start at a high pumping speed (usually quoted by the manufacturer), then as the pressure drops in the chamber, so does the speed of the pump. A quantity that is very useful in describing the system being evacuated is the throughput. Throughput is defined as the quantity of gas (in pressure-volume units) flowing per second through a specified cross-section of the system [$Q = d(PV)/dt$]. For steady-state flow in a pipe with no sources or sinks, the throughput of gas between two points is proportional to the pressure difference between those points (Ref. 3, Ch. 2). This may be expressed as:

$$Q = U(P_2 - P_1) \quad 1.1$$

where U is the conductance of the section between the two points. When several sections of a pumping system are connected in series, then the combined conductance U_s is given by:

$$U_s - 1 = U_1 - 1 + U_2 - 1 + U_3 - 1 \dots$$

The Beginner's Guide to Cryostats and Cryocoolers

A pump's speed (S) for a particular gas is defined as the ratio of the throughput at the pump entrance to that gas' pressure. Therefore:

$$S = Q/P \quad 1.2$$

When a pump is attached to the evacuation valve through a specific pumping line, the gas throughput at the pump is the same as that of the gas leaving the vacuum jacket. Because the pressure at the pump is lower than that at the vacuum jacket (when Dewar evacuation is in progress), this results in an effective pumping speed (S_d) at the Dewar, where the pressure is P_d , obtained from the relation:

$$Q = SP = S_d P_d \quad 1.3$$

When this is combined with 1.1, the resulting effective pumping speed at the Dewar becomes:

$$S_d = S/(1 + S/U) \quad 1.4$$

The conductance of a long tube (length L much greater than the radius r) for air at room temperature is approximately $100 r^3/L$ (Ref. 3, Ch. 1) L/s (with r and L expressed in cm). If a 38 mm \times 1.56 m long (1.5 in diameter \times 5 ft long) evacuating line is used, this results in 4.5 L/s conductance. Therefore, using a 12.7 L/s pump (27 ft³/min, or CFM) at one end of this evacuating line, the effective pumping speed at the other end would drop to 3.3 L/s (7 CFM).

A variety of vacuum gauges can be used at different pressure ranges. A thermocouple gauge is often used with rotary pumps ranging from 1 atmosphere to 10^{-3} Torr. An ionization or cold cathode gauge is commonly used for lower pressures (10^{-3} to 10^{-7} Torr). These gauges are usually located at the pump opening, and it is important to note that depending on the pumping line connecting it to the Dewar, the pressure at the Dewar can be significantly higher (at room temperature). Therefore, in the above example of the 1.5 m (5 ft) line, using equation 1.3, the pressure at the end of the line is calculated at 3.8 times the pressure at the pump.

Once the vacuum jacket of the Dewar is evacuated and the Dewar cooled (to LN₂ or LHe temperatures), the pressure in the cold region drops. An approximate relation that holds under these low pressures is that the pressure varies in proportion to the square root of the absolute temperature ($P/\sqrt{T} = \text{constant}$; Ref. 2, Ch. 4). It is therefore recommended that when liquid helium is transferred into a Dewar, the Dewar evacuation valve should be closed. If this is not done, the cryopumping occurring due to the liquid-helium-cooled cold surfaces may pump back oil vapors (from the pump) into the vacuum jacket. This is especially true if the pumping station does not have a liquid nitrogen cold trap. This contaminates the vacuum jacket and results in a higher heat load and poor Dewar performance.

Very often, metal Dewar designs require thin-walled 0.25 mm to 1.5 mm (0.01 in to 0.06 in) thick stainless steel tubing for the helium (or nitrogen) reservoirs. These reservoirs are, therefore, not designed to withstand a pressure difference of one atmosphere on their exterior surface and will collapse. They are, however, designed to withstand an atmosphere pressure difference on their inner surface. A potentially dangerous situation can occur if one evacuates the helium reservoir while the outer jacket is at atmospheric pressure. It is therefore best to always maintain the vacuum jacket under vacuum and preferably install a pressure gauge on this jacket to indicate the pressure inside the jacket. It is also good to avoid introducing helium gas inside the vacuum jacket because it has high thermal conductivity (about 12 times that of nitrogen gas), will not condense at 4.2 K, and is generally more difficult to remove than air or nitrogen. This is especially true in transfer lines and vapor-shielded Dewars with MLI in their vacuum jackets.

2. Liquid helium and nitrogen Dewars

As mentioned earlier, liquid helium and nitrogen Dewars usually consist of one or more reservoirs surrounded by a vacuum jacket, which isolates these reservoirs from room temperatures. Most Dewars are made from stainless steel because they can be easily and permanently joined to similar or dissimilar (copper, brass, etc.) metals by welding (in an inert gas atmosphere) or silver soldering. Such joints can withstand many cycles between room temperature and helium (or nitrogen) temperature and remain leak-tight after years of use. Other Dewars are manufactured from low thermally conducting epoxy-fiberglass necks and aluminum reservoirs.

A. Welded Dewars

The simplest Dewars have an all-welded construction with direct access to the cryogen reservoir through the top of the Dewar. These Dewars are used for storage or for directly immersing the sample in the cryogen. Such Dewars have an evacuation valve for evacuating the space surrounding the cryogen reservoir and a safety pressure relief valve to protect the vacuum jacket should an internal leak develop. Such a leak results in the cold cryogen entering the vacuum jacket, warming up after contact with the room temperature wall, and expanding. This could result in a high-pressure build-up in the vacuum jacket. A safety pressure relief valve set to open at 2 to 5 lb/in² (psi) above atmospheric pressure will safely vent the leaking gas to the outside of the vacuum jacket and prevent any dangerous pressure build-up.

The Beginner's Guide to Cryostats and Cryocoolers

A simple open-neck “bucket type” liquid nitrogen Dewar is shown in Figure 2.1. The liquid nitrogen reservoir is a cylinder of diameter A , and the outer jacket is a concentric cylinder of diameter B . The space between A and B is evacuated through the evacuation valve, which should be a good bellows sealed valve. The liquid nitrogen cools the charcoal getter located in the vacuum jacket and helps maintain a good vacuum over extended periods of operation. Such a Dewar can be used to immerse a sample or any insert directly in liquid nitrogen.

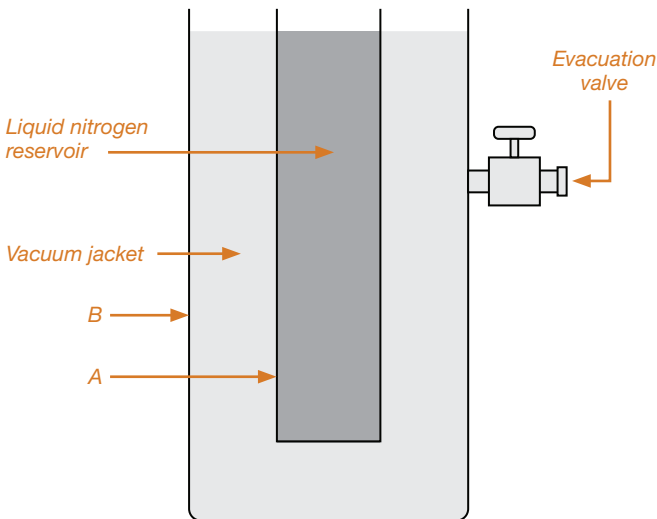

Figure 2.1: Open-neck liquid nitrogen Dewar

Figure 2.2 shows an open-neck (bucket type) liquid helium Dewar where the helium reservoir is a cylinder of diameter A . This is surrounded by a nitrogen reservoir (annular space between tubes B and C), which shields the surface of the helium reservoir from room temperature radiation. The space surrounding the helium reservoir (between A and B) and the space surrounding the nitrogen reservoir (between C and D) is evacuated through the evacuation valve on the outer jacket (diameter D). These two spaces are connected through a slot in the radiation shield, which is bolted to the bottom of the nitrogen reservoir. Therefore, both spaces are evacuated simultaneously through the evacuation valve. The radiation shield bolted to the bottom of the nitrogen reservoir is usually made from a good thermal conductor (aluminum or copper). In contrast, the rest of the Dewar is made from stainless steel or a combination of aluminum and low thermal conducting epoxy fiberglass (in the neck region). For stainless steel Dewars, tube A has a wall thickness of about 0.64 mm to 1.57 mm (0.025 in to 0.062 in) for larger diameter necks to reduce the conductive heat load into the liquid helium. For many stainless steel Dewars, the thin-walled helium reservoir should not be evacuated before ensuring the main Dewar is under vacuum.

When the nitrogen reservoir is filled with liquid nitrogen, the thermal anchor F and the region of the helium reservoir neck to which it is connected will be cooled to approximately 80 K. This intercepts the conductive heat load into the helium reservoir from room temperature along the neck of the helium reservoir (top portion of tube A). Generally, the top of the helium reservoir is separated from the thermal anchor F by some distance to provide thermal isolation for the liquid helium (which is at ~ 4.2 K) and the 80 K temperature at F .

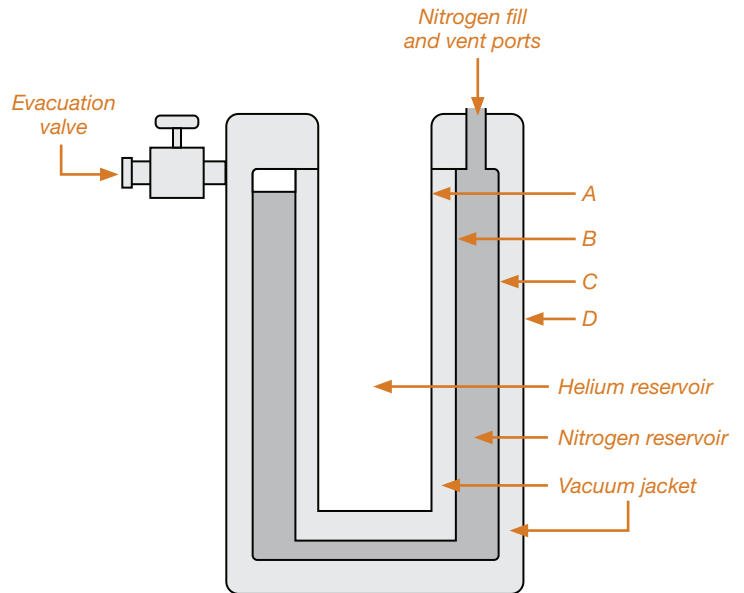

Figure 2.2: Open-neck nitrogen shield liquid helium Dewar

Other types of bucket Dewars are also shown in Figures 2.3 through 2.5.

Figure 2.3 shows a vapor-shielded “belly” type Dewar where the helium reservoir has a much larger diameter than the neck that connects it to the room temperature flange. For aluminum Dewars, this neck is made from special impregnated epoxy fiberglass tubes connected to the aluminum top flange and the top helium reservoir flange with special epoxies designed to offer a strong vacuum-tight joint and support. This Dewar also has a narrower “tail,” which is particularly useful for immersing a superconducting magnet that must always be covered with liquid helium during operation. The smaller volume around the magnet reduces the amount of liquid helium necessary to cool and maintain the magnet in the liquid. The belly diameter (and length) determines the helium capacity, while the neck diameter B and tail diameter C determine the maximum size of the insert that fits inside the Dewar. The outer diameter D is typically 127 mm (5 in) larger than the belly.

The Beginner's Guide to Cryostats and Cryocoolers

Figure 2.4 shows an ultra-low-loss bucket Dewar that includes a liquid nitrogen reservoir surrounded by MLI, plus an intermediate radiation shield between the nitrogen reservoir and the helium reservoir. This shield floats at a temperature between liquid nitrogen and liquid helium and significantly reduces the radiation heat load at the helium reservoir. The result is an ultra-low loss Dewar that typically reduces the helium consumption by a factor of two or more. The belly diameter (and length) determines the capacity of the helium reservoir, while the neck diameter B and tail diameter C determine the maximum size of the insert that fits inside the Dewar. The nitrogen reservoir is located in the upper section of the Dewar, with an outer radiation shield (cooled by the nitrogen reservoir) surrounding the helium reservoir. A second radiation shield (cooled by the helium vapor venting through the neck) is between the helium reservoir and the first radiation shield. The vacuum spaces surrounding the reservoirs and radiation shields are interconnected, so the Dewar requires only one evacuation valve.

Any insert placed in the helium reservoir should contain several radiation baffles (usually made from copper) in the neck region, with a diameter 6.4 mm (0.25 in) less than that of the neck. These baffles are cooled by the escaping helium vapor and intercept the radiational heat load from the room temperature top flange of the insert (which can be very large). The baffles also force the vapor to make more intimate contact with the helium reservoir neck, intercepting about 85% of the conductive heat load down the neck (when properly designed).

The inserts that are placed into this type of Dewar could be a simple immersion type or a variable temperature cryostat. The former usually positions the sample in direct contact with the liquid helium at 4.2 K or lower. Lower temperatures are achieved by reducing the pressure on top of the helium through an appropriate pumping port. Variable temperature inserts (as discussed later) position the sample in an environment where its temperature can be raised above 4.2 K (usually to room temperature or higher) or reduced below 4.2 K (to 1.5 K, 0.3 K, or a few mK). These inserts should always be supported by thin-walled stainless steel or epoxy fiberglass tubing to reduce the conductive heat load into the helium reservoir. This is because the latent heat of vaporization of liquid helium is extremely small (1 W will boil off ~1.4 L LHe/h when absorbed by the liquid). Also, any wiring that enters the helium reservoir should be as thin as possible and (whenever possible) made from poor thermal conductors such as manganin, phosphor bronze, stainless steel, etc. In all cases, some of the heat load should be intercepted with liquid nitrogen, which has a much higher heat of vaporization (1 W boils off 22.4 mL LN₂/h). Or you can use the tremendous cooling power of the boiling helium vapor between 4.2 K and 300 K (about 80 times the latent heat of vaporization of LHe at 4.2 K).

Inserts that contain superconducting solenoids that need to be immersed in liquid helium are also placed in these “bucket-type” Dewars. Special counter-flow vapor-cooled high-current leads should be used with such inserts to intercept most of the heat generated in those leads before reaching the helium reservoir. We discuss these and other types of inserts in Chapter 3.

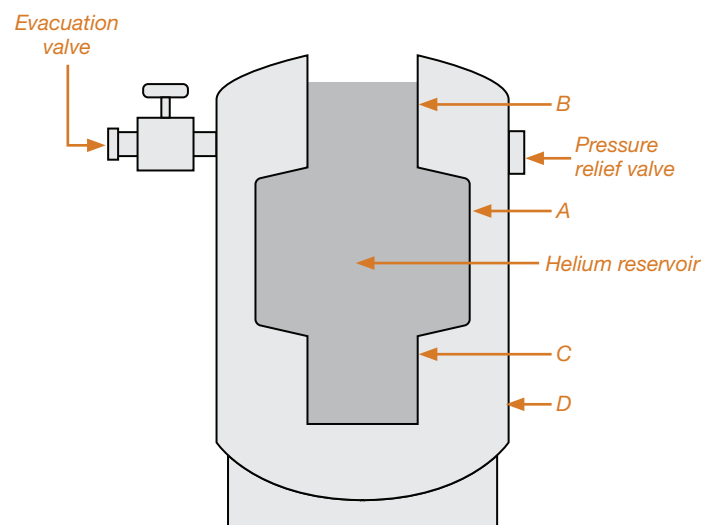

Figure 2.3: Superinsulated liquid helium belly Dewar

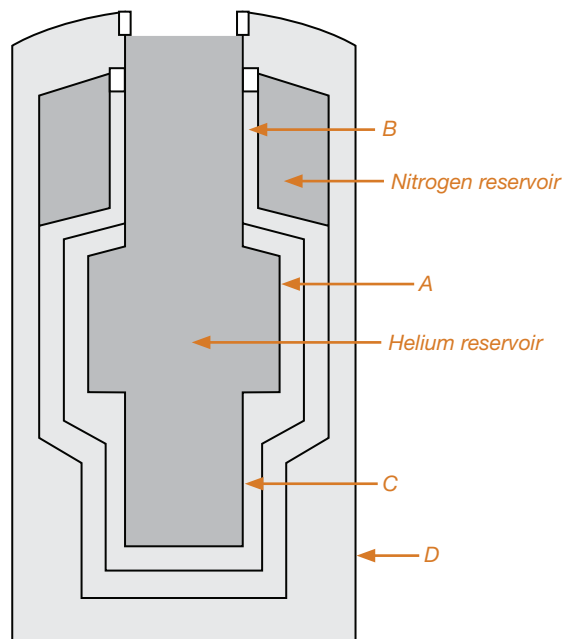

Figure 2.4: Nitrogen-shielded low-loss helium Dewar

The Beginner's Guide to Cryostats and Cryocoolers

B. Detachable-tail Dewars

While some liquid helium and nitrogen Dewars have an all-welded design, others can be made with detachable bottom flanges for additional versatility. In this case, a crushed indium seal is used at the bottom of the helium reservoir, and an o-ring seal is used at the bottom of the outer jacket. A radiation shield flange is mechanically attached to the bottom of the annular nitrogen reservoir. This arrangement offers access to the helium reservoir through the bottom of the Dewar. It also allows various tail extensions to be welded to these flanges to give a variety of configurations.

C. Tail extensions

Tail extensions are one of the main advantages of a detachable-tail Dewar. These result in either constant or variable temperature cryostats that can be used for a large variety of scientific experiments at low temperatures. A few examples of these tail extensions follow.

1. Immersion tails

The simplest extension tail extends the helium reservoir directly into a narrower region (tail) below the Dewar. Figure 2.5 shows a set of tails attached to the bottom of a detachable-tail Dewar. The helium tail (diameter A) is simply an extension of the helium reservoir with liquid helium inside it. The (aluminum) radiation shield tail (diameter B) is welded to the radiation shield flange. The flange is bolted to the bottom of the nitrogen reservoir to cool it conductively. The outer tail (diameter C) is welded to the bottom o-ring sealed flange and now becomes an extension of the outer vacuum jacket. This configuration's main application is to fit in a limited space, such as the pole gap of an electromagnet. The usual clearance required between the helium tail and outer tail diameters is a function of the length L but is normally 25 mm ($C - A = 25$ mm [1 in]). This clearance may be reduced to 12.7 mm (0.5 in) or less with the appropriate use of concentricity spacers between the tails to avoid physical contact, which would result in a thermal short. Adding such spacers between the tails results in an additional heat load into the helium or nitrogen reservoir, which could result in a higher cryogen consumption. These spacers are only added when dictated by the geometrical configuration desired.

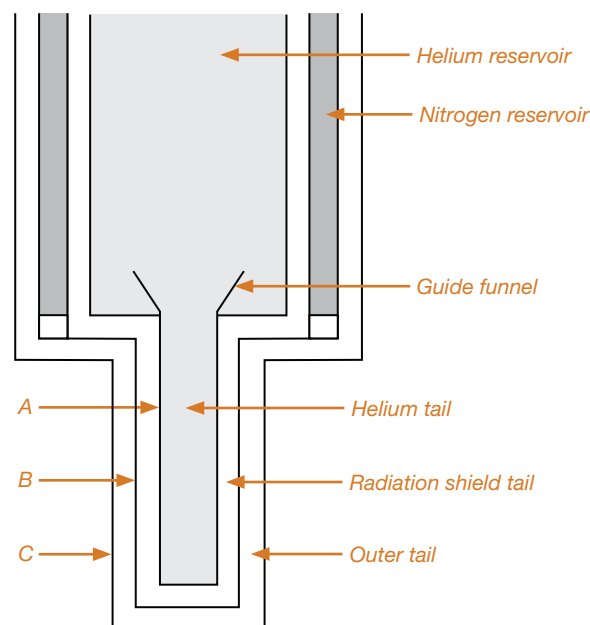

Figure 2.5: Immersion tubular-tail Dewar

A bonus of such a tail extension is that optical access to the sample does not need to pass through the (double-walled) nitrogen reservoir. Because there is vacuum on both sides of this tail, a simple opening in the radiation shield tail is all that is required. The hole in the radiation shield tail, necessary for optical access to the helium tail, also allows (300 K, IR) radiation from the outer tail to fall directly onto the helium tail. This additional heat load on the helium tail is about 25 to 50 mW/cm² near the opening in the radiation shield. To reduce this heat load, minimize the hole size or install an additional window (cooled to the temperature of the radiation shield). Installation of radiation shield windows usually requires another window block at that tail, resulting in a larger outer tail, which is not always desirable. However, when such windows are correctly installed, they can practically eliminate the radiational heat load through the radiation shield ports. For some specific applications (such as gamma rays or x-rays), thin film Mylar (or aluminized Mylar) windows can be wrapped directly onto the cylindrical tails, therefore requiring no more room than non-optical (tubular) tails.

Windows on the outer tail are also installed on a window block with flat faces and are usually o-ring sealed. A retainer holds the window in place before the Dewar is evacuated. Once the vacuum jacket is evacuated, the windows are held against the o-ring by atmospheric pressure. With no radiation shield windows, typically, the outer tail diameter will be 19 mm greater than the inner tail ($C - A = 19$ mm [1.5 in]), and the distance between the two outer windows (180° apart) will be 19 mm (0.75 in) larger than the outer tail diameter (A). The clear view of the windows is designed to offer the required solid angle as measured from the center of the sample tube, consistent with the limitations dictated

The Beginner's Guide to Cryostats and Cryocoolers

by the cryogenic seal of the inner window. The size and material type of windows used are also a function of the required transmission range (wavelength or frequency). Various window materials that withstand thermal cycling between helium and room temperature are available to cover most regions of the electromagnetic spectrum. The dimensions of the outer tail and window block can sometimes be reduced by using spacers between the various tails and by epoxying the outer windows. This latter option minimizes the distance between opposing windows because the o-ring and tapped holes for the window retainer are no longer required.

These examples of tail extensions are for applications where the sample is immersed in the liquid cryogen. This is usually done by introducing the sample through the top of the Dewar, using a long thin wall stainless steel tube to support it off the top of the neck. The liquid cryogen (and sample) temperature may then be reduced below the normal boiling point by reducing the pressure on top of the liquid. Using a typical 27 CFM roughing pump can usually reduce the temperature of a helium reservoir to below 2 K (at a pressure of 24 Torr or less).

2. Tails for sample in vacuum

Some experiments require the sample to be cooled down while surrounded by a vacuum. For these cases, the sample can be located in the Dewar vacuum using a tail extension similar to the immersion tails, except that the sample location is below the bottom flange of the inner tail.

Figure 2.6 shows a tail extension where a copper flange seals the bottom of the helium tail. The face of the copper flange, which lies in vacuum, contains some dead tapped holes and is at a distance X above the window center line. This copper piece acts as a sample mount (usually called a cold finger) for attaching samples in vacuum. Because the cold finger is in contact with the liquid cryogen (above it), it remains at the temperature of the cryogen. Samples or sample holders attached to the cold finger must be thermally anchored very carefully in order to be cooled because the cooling is primarily achieved by contact with the cold finger (in vacuum). Using pressure contacts with an indium interface, suitable conductive epoxies, or silicone grease usually does this. It is always best to install a sensor at the sample to measure its actual temperature, which may be several degrees above the temperature of the cold finger. A second radiation shield attached to the cold finger, and surrounding the sample, is usually quite helpful in reducing the radiational heat input into the sample.

The same configuration can be provided without outer windows for experiments not requiring optical access to the sample. In such a case, the diameter of the outer tail will be about 25 mm larger than the diameter of the inner tail ($C - A = 25 \text{ mm}$ [1 in]). When windows are supplied on the outer tail, the diameter of the outer tail does not change, and the window-to-window distance (for 180° opposing windows) will be about 19 mm (0.75 in) larger than the outer tail diameter (C). Once again, the outer tail diameter and window-to-window distance can be reduced by concentricity spacers and epoxyed windows.

The liquid cryogen (and sample mount) temperature is varied in the same manner as the immersion tails by reducing the pressure on top of the liquid in the inner reservoir. A radiation shield bolted to the sample mount (surrounding the sample) is again advisable, especially at lower temperatures, to help reduce the temperature differential between the sample and its holder.

Changing samples in such a configuration significantly differs from the immersion tail configuration. In the immersion case, samples can be removed and introduced into the cryogen any time the cryogen is at atmospheric pressure. This cannot be done when the sample is in vacuum. Now, the Dewar must be free of cryogen, and preferably at room temperature, before the sample is removed or installed because the Dewar vacuum must be broken. If the Dewar is still cold, then air and moisture can condense (or freeze) on the Dewar vacuum walls, which would need to be completely cleaned and dried before evacuating and re-cooling the Dewar. For this reason, too, it is undesirable to provide such a tail for a Dewar with MLI because re-evacuation can take a long time, especially if any moisture condenses on the MLI.

An example is the so-called detector-cooling Dewar used for cooling a sample to a fixed temperature using either liquid nitrogen or liquid helium. Access is typically through an o-ring sealed bottom flange or tail section, with specialized designs that allow the Dewar to rotate by 90° or 180° for horizontal or inverted operation. The liquid nitrogen temperature may be lowered by reducing the pressure on top of the nitrogen (or helium) reservoir with special internal heat exchangers that allow the Dewar to work even with frozen nitrogen (approximately 63 K to 50 K). The Dewar size depends on the required hold time or cold plate size. Electrical feedthrough access is typically located on the top flange so that the wiring to the cold plate region remains intact when the bottom section is removed to access the cold plate. Ultra-high vacuum (UHV) compatible units have all metal seals and generally have electropolished stainless steel reservoirs and vacuum jackets and gold-plated copper cold plates or cold fingers.

The Beginner's Guide to Cryostats and Cryocoolers

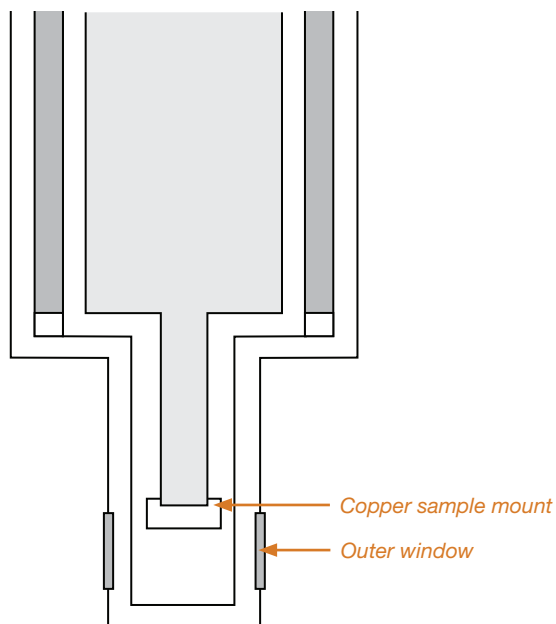

Figure 2.6: Cold finger/sample in vacuum

3. Variable temperature cryostats

The simple helium (or nitrogen) Dewars discussed previously allow cooling an apparatus to the temperature of the boiling cryogen, either by direct immersion or by attachment to a cold finger in contact with the cryogen. Reducing the pressure on top of the cryogen can reduce the temperature below the typical boiling point of the cryogen. If the temperature needs to be varied above that of the cryogen, then an external heat input into the sample holder is needed. Any heat added to a sample holder in good thermal contact with the liquid cryogen will quickly be transmitted into the cryogen and boil it away without significantly raising the temperature of the sample. Therefore, the first requirement for obtaining higher temperatures is to thermally isolate the sample from the cryogen. If this is done after the sample is cooled, then any heat added to the sample holder increases its temperature above that of the cryogen while a temperature gradient develops across the isolating element. In a well-designed system, little heat is required to raise the sample's temperature well above the cryogen's temperature without significantly increasing the cryogen consumption rate.

Another method of obtaining temperature variation above the normal boiling point is to channel a small flow of the cryogen into the sample region and vaporize the cryogen with an external heat source to raise its temperature to the desired level. This method works very well with liquids with a low vaporization heat (e.g., helium) while the sample is placed in the path of the heated flowing vapor. When liquids having large heats of vaporization (e.g., nitrogen) are used, it becomes difficult to vaporize the liquid and increase its temperature. In such a case, either work with easily heated flowing cold vapor or separate the sample from the flowing liquid and then add heat to the sample.

Several kinds of variable temperature cryostats are described in the following, falling under the general categories discussed above for temperature variation. Designed for liquid helium or liquid nitrogen, these cryostats can also usually use other cryogens (liquids air, oxygen, argon, neon, hydrogen) with certain modifications dictated by safe gas handling.

A. Thermal impedance cryostats

A simple method for obtaining variable temperatures for samples in vacuum configurations is to modify the cold finger configuration by inserting a tight-fitting, thermally insulating cylinder into the inner tail. This arrangement is shown in Figure 3.1.

The insulating cylinder presents a thermal impedance (T_i), which isolates the copper sample mount from the cryogen above it. A heater is also installed at the sample mount to raise its temperature. Initially, the sample mount is at the same temperature as the cryogen. When heat is introduced through the heater, any cryogen in contact with the sample mount evaporates, resulting in a vapor bubble on top of the sample mount. This, in conjunction with the insulating cylinder, forms the thermal impedance necessary to isolate the sample mount from the liquid cryogen. The temperature of the sample mount can then be increased above that of the cryogen by increasing the current through the heater. This insert works well with both liquid helium (4.2 to 77 K) and liquid nitrogen (77 to 300 K/500 K). For temperatures below the normal cryogen boiling point, the insulating cylinder is removed (from the top of the Dewar), and the pressure on top of the cryogen is reduced. This insert forms the basis for the Environment by Janis SSVT system for temperature variation.

The Beginner's Guide to Cryostats and Cryocoolers

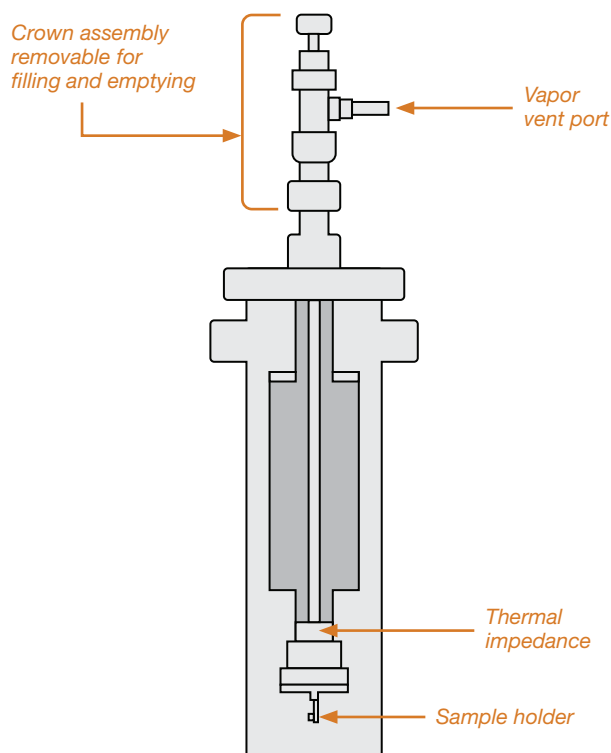

Figure 3.1: Thermal impedance cryostat

B. Exchange gas cryostats

Another method for varying the temperature of the sample mount is by indirectly connecting it to the cooling source through a gas (usually helium) at sub-atmospheric pressure. As the pressure of the gas is varied between 760 Torr and 10^{-4} Torr, the thermal link between the cooling source and the sample mount changes by several orders of magnitude. This method is effective for making variable temperature cryostats in a variety of configurations, with the sample either in contact with the exchange gas or on a cold finger in vacuum (with the cold finger contacting the exchange gas). Such cryostat inserts can be introduced into the cryogen reservoir of an open-neck Dewar, built into a detachable-tail Dewar, or incorporated into a closed-cycle refrigerator (discussed later). The exchange gas mechanism forms the basis for the Environment by Janis VT system for temperature variation. We discuss a few examples of such systems next.

1. Exchange gas insert for open-neck Dewars

Figure 3.2 shows an insert introduced into the helium reservoir of an open-neck Dewar (only the liquid helium reservoir is shown). The insert consists of the stainless steel sample tube, with its lower portion made from copper to present an isothermal surface around the sample. The sample mount is supported by a thin-walled stainless steel tube from the top of the cryostat (sample positioner). The sample tube is evacuated through the exchange gas valve prior to cooldown, then backfilled with helium gas. A more sophisticated 3-valve assembly (instead of the sample exchange gas valve) can be installed to facilitate the evacuation and backfilling procedure. A pressure gauge in the same region monitors the pressure of the helium exchange gas in the sample tube.

After cooldown, the exchange gas pressure is usually adjusted to about 1 to 100 mTorr, depending on the heat load and the lowest temperature desired. Higher pressures result in good thermal linkage between the sample and the cryogen, which is desirable at low temperatures. The heater located at the sample mount is used to raise the temperature of the sample that is thermally anchored to the sample mount. A temperature sensor is usually installed in the same region to monitor the sample temperature. For operation above 77 K, liquid nitrogen can replace the liquid helium in the main reservoir. Lower exchange gas pressures should generally be used at higher temperatures (77 K with liquid helium or 300 K with liquid nitrogen) to decrease the thermal link between the sample and the cryogen. This results in less heat necessary to raise the sample temperature and, therefore, less heat absorbed by the reservoir, resulting in a lower cryogen evaporation rate.

Temperatures below the cryogen boiling point may be obtained by reducing the pressure on the main reservoir while increasing the exchange gas pressure. In some cases, liquid may have to be transferred into the sample tube (or liquid condensed by over-pressurizing the sample tube) to reach 4.2 K or 77 K with liquid helium or nitrogen, respectively. Increasing the exchange gas pressure has the disadvantage of increasing the conductive heat load from room temperature into the main reservoir. In general, this method of temperature variation works quite well and results in excellent temperature stability. Its primary disadvantage is that the heat introduced at the sample is absorbed by the liquid cryogen and evaporates a certain amount as determined by the latent heat of the cryogen. Therefore, as it warms to room temperature, no use is made of the enthalpy or cooling power of the cold helium (or nitrogen) vapor. Also, the insert shown in Figure 3.2 requires good thermal anchoring between the sample and its holder because the sample is cooled by the exchange gas but is

The Beginner's Guide to Cryostats and Cryocoolers

heated through contact with the sample mount. A more complicated (two-wall) insert can be set up with heating introduced to the sample tube's lower (copper) section to heat the exchange gas. The exchange gas then heats both the sample and sample mount. Such an arrangement eliminates the thermal interface between the sample and the sample mount and results in an easier determination of the sample temperature.

The cryostat's top-loading design allows sample interchange while the Dewar is cold. This is accomplished by bringing the pressure in the sample tube up to atmospheric, then quickly removing the sample mount and covering the top sample tube entrance to prevent air or moisture from entering it.

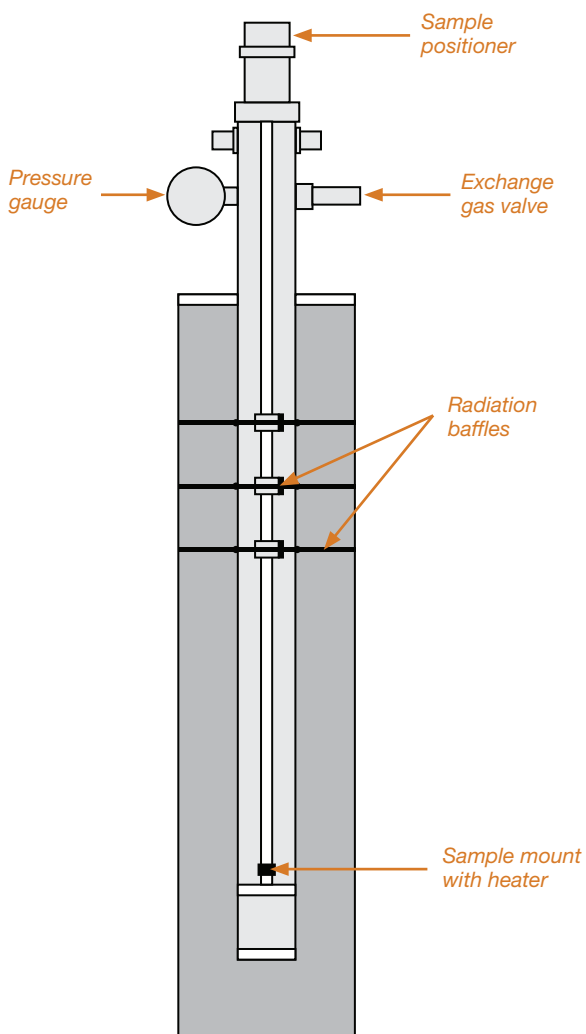

Figure 3.2: Exchange gas insert

2. Exchange gas inserts for detachable-tail Dewars

Several variable temperature cryostat configurations can be obtained using the same concept for isolating and connecting the sample to the cooling source through an exchange gas in a detachable-tail Dewar. Two examples are discussed in the following, showing configurations that place the sample inside the exchange gas column or on a cold finger (in vacuum). Both examples show optical sample access, but the tail insert can be simplified by eliminating the windows if no optical access is required. The more compact non-optical insert tail dimensions can generally be optimized for tight-fitting experiments (such as fitting in the pole gap of an electromagnet).

i. Sample in exchange gas

Figure 3.3 shows a detachable-tail Dewar with an exchange gas tail insert, placing the sample in contact with the exchange gas and providing optical sample access. The tails are attached to the Dewar bottom flanges, with the innermost tail permanently attached to the helium reservoir bottom flange. This tail becomes the sample tube, extending to the cryostat's top. It contains the exchange gas, with the sample loaded through the top of the cryostat. The lower portion of the sample tube is usually made from copper, part of which lies inside the helium reservoir, while the Dewar vacuum surrounds the lowest part. This configuration maintains the lower portion close to liquid helium temperature (or liquid nitrogen, in nitrogen Dewars), and the sample is located in this region. The upper part of the sample tube is made from stainless steel to reduce the conductive heat load from room temperature. The pressure of the exchange gas determines the thermal link between the sample and the cryogen in the same manner as the previous cryostat insert. A radiation shield and an outer tail with windows surround the innermost tail in the same manner as the immersion tail units (Figure 2.6). Installation of radiation shield windows reduces the heat load on the sample tube, reducing the helium consumption and the lowest reachable temperature at the sample. The sample can also be immersed in liquid helium if the liquid is transferred directly into the sample tube or condensed by over-pressurizing helium gas in the sample tube. The latter option boils off a significant amount of helium from the main reservoir because the warm helium gas is cooled and condensed by dumping this energy into the liquid helium in the main reservoir.

The Beginner's Guide to Cryostats and Cryocoolers

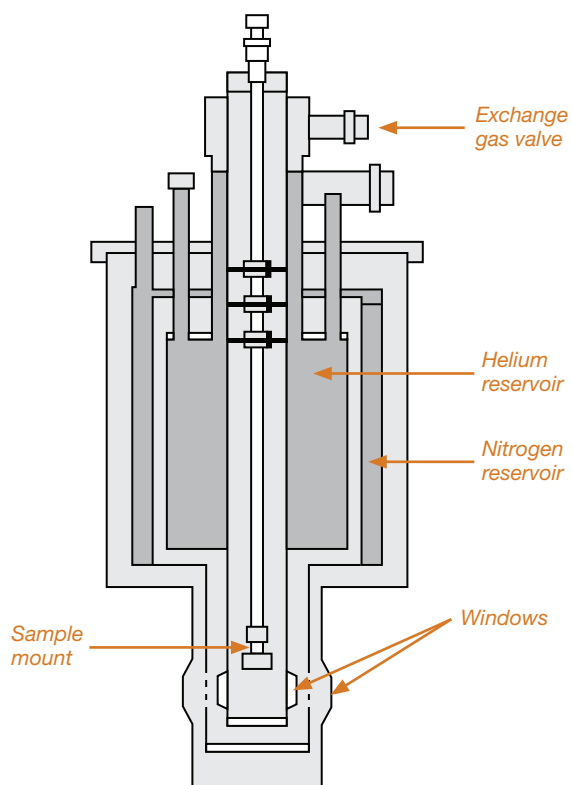

Figure 3.3: Optical exchange gas cryostat

ii. Sample in vacuum

Figure 3.4 shows a set of insert tails that provides a cold finger for attaching a sample in (the Dewar) vacuum. The cold finger is isolated from the helium reservoir by a thin wall stainless steel tube, which also acts as the exchange gas space. The exchange gas inside this tube forms the (variable) thermal link between the cryogen and the cold finger. A (copper) heat exchanger is connected to the cold finger to increase the link between the exchange gas and the cold finger, increasing the cooling power at the lowest temperature. A heater, located at the cold finger, is used to raise and control the temperature of a sample attached to the sample mount.

Exchange gas cryostats work well with either liquid helium or liquid nitrogen Dewars. In a helium Dewar, the helium reservoir may be filled with liquid nitrogen whenever temperatures above liquid nitrogen are required. Helium gas is usually used as the exchange gas with either liquid helium or liquid nitrogen because of its high thermal conductivity, but nitrogen gas could be used when liquid nitrogen is the cryogen in the main reservoir.

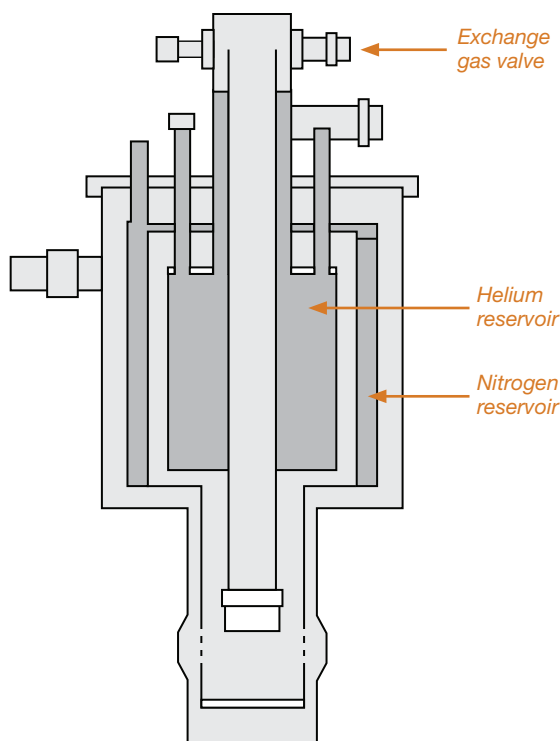

Figure 3.4: Sample in vacuum exchange gas cryostat

C. Continuous flow cryostats

As discussed above, temperature variation can be obtained by continuously channeling a small flow of cryogen to the sample region and controlling its temperature. The cryogen may be contained in the main reservoir of the Dewar (such as the Environment by Janis SuperVariTemp cryostats), or it could be continuously transferred from a storage Dewar (such as the Environment by Janis SuperTran cryostats). Because the cryogen has to be vaporized before raising its temperature, these cryostats are usually designed to operate with liquid helium. This is especially true when the sample is located in the flowing vapor. Sometimes, the same cryostat may also be used with liquid nitrogen, with or without minor modifications. Several examples of such cryostats are discussed in this section.

1. Flow cryostats with detachable-tail Dewars

The detachable-tail Dewar with a cryostat channels liquid helium from the main reservoir to a sample chamber isolated from the helium reservoir. This is done through a helium valve at the bottom of the helium reservoir, connected to a heat exchanger/vaporizer at the bottom of the sample tube via a small capillary tube. The capillary tube and lower portion of the sample tube are located in the Dewar vacuum and surrounded by the radiation shield and outer tails. The isolation tube diameter is usually 6.4 mm (0.25 in) larger than the sample tube diameter, with the

The Beginner's Guide to Cryostats and Cryocoolers

Dewar vacuum extending to the region between those two tubes. The helium valve is generally opened slightly to allow a small flow of liquid helium from the helium reservoir into the heat exchanger at the bottom of the sample tube. At that point, heat may be added to vaporize the liquid helium and raise its temperature (usually up to 300 K) to change the temperature of the sample attached at the sample mount. The warm helium vapor flows up the sample tube and escapes from a vent port at the top of the cryostat. Because the sample tube is isolated from the helium reservoir, the warm vapor flowing in the sample tube does not cause additional helium boil-off from the reservoir. Furthermore, the helium vapor temperature can also be lowered by reducing the pressure at the sample tube without affecting the main reservoir. Therefore, flowing vapor at 1.8 K is easily obtained with a medium-sized mechanical pump (typically 10^{-17} ft³/min or 5 to 9 L/s). The sample tube can also be quickly filled with liquid helium by opening the needle valve, and if desired, the pressure can be reduced to lower the liquid helium temperature (to 1.5 K or less). The helium reservoir is usually slightly pressurized (to about 1 to 2 psig) by sealing all reservoir entrances except one that contains a pressure relief valve set at 2 psig. This arrangement provides a constant pressure gradient to drive the liquid helium through the capillary tube into the sample tube.

One of the significant advantages of this cryostat is that a sample mount heater is not necessary to heat the sample, and it does not have to be thermally anchored to its mount. This is because the sample's cooling (and heating) is achieved by controlling the temperature of the flowing helium vapor, which makes direct sample contact. Attaching a temperature sensor close to the sample gives a very accurate measure of the sample's temperature because both the sample and sensor are being cooled (or heated) by the same flowing vapor at the same location. A control sensor is usually installed at the vaporizer and a second sensor at the sample mount to precisely measure the sample temperature. Most commercially available automatic temperature controllers easily handle such an arrangement. A typical temperature sweep between 4.2 K and room temperature takes about 30 to 45 min as long as the heat exchanger's mass remains reasonably small.

Another advantage of this system is that operation below 4.2 K does not require reducing the pressure on the main reservoir, which usually evaporates about 40% of the liquid helium by the time it is cooled to 2.2 K. This is particularly important if a superconducting magnet is located in the helium reservoir. Furthermore, throttling the valve and reducing the pressure in the sample tube results in a stream of 1.8 K helium flowing past the sample. This mode presents the least amount of interference in optical experiments where the presence of superfluid (or normal) helium cannot be tolerated.

This variable temperature system is the basis for the Environment by Janis SuperVariTemp cryostat with the sample in flowing helium vapor. Optical sample access is provided by adding outer and inner windows to the tail region, with the final configuration resembling the tail region of Figure 3.3. This system can also dissipate large amounts of heat that may be generated at the sample (due to laser beams or other sources). This is because the helium valve and pressure gradient can be adjusted to provide a large flow (a few L/h of liquid helium) into the sample tube.

The sample holder is top-loaded into the sample tube, and the sample positioner adjusts its position at the top of the cryostat. A simple 6.4 mm (0.25 in) tube passing through an o-ring compression seal allows rotation as well as translation of the sample mount about the Dewar axis. Above 4.2 K, with the pressure in the sample tube at 1 atmosphere, changing samples is simple because the helium flow (coming in through the bottom of the sample tube) prevents air from easily entering the sample chamber.

Two useful configurations can be provided by modifying the heat exchanger's (vaporizer) design in this insert. The first offers bottom optical access by making a toroidal vaporizer and adding windows at the bottom of the outer and radiation shield tails. One slight disadvantage of this arrangement is that the inner bottom window gets dirty from any foreign material entering the sample tube and settles at the bottom. The other heat exchanger modification is to machine it with a flat mounting surface (with dead-tapped holes) so that it acts as a cold finger for attaching samples in vacuum. The capillary tube can now enter through the side (as opposed to the bottom) of the heat exchanger into the venting tube (what used to be the sample tube) to not interfere with the sample mounting surface of the cold finger. The sample is located in the Dewar vacuum and can only be replaced by breaking the vacuum with the Dewar at room temperature.

The temperature stability (at the sample) between 4.2 K and 25 K is usually better than ± 0.1 K using an appropriate automatic temperature controller. The stability is inherently limited due to helium's two-phase mixture (liquid and vapor) flowing past the sample. Should better stability be required, a simple exchange gas insert with a bottom isothermal section (made from copper) can be inserted through the top of the cryostat inside the sample tube. This insert now becomes the new sample tube, resulting in much better temperature stability at the sample. Such an insert is also useful for equipment that may be disturbed by any gas flowing across the sample, such as Faraday Balance experiments. The static exchange gas sample location eliminates any disturbance due to flowing helium vapor. It is also useful when heating the sample above 80 K because it can reduce the radiational heat load into the main reservoir and the overall helium consumption of the cryostat.

The Beginner's Guide to Cryostats and Cryocoolers

Where the vaporizer design allows the vaporization of a reasonable flow (50 to 500 cc/h) of liquid helium entering the sample tube, attempting to do this with liquid nitrogen is usually unsuccessful. This is due to the relatively large heat of vaporization of liquid nitrogen. When liquid nitrogen must be used, a modified design for the heat exchanger and bottom of the sample tube can improve the heat exchange between the heater and the liquid nitrogen. This design can then be used for operating the system above liquid nitrogen temperature, using a limited flow of liquid nitrogen into the heat exchanger.

2. Flow cryostat inserts for open-neck Dewars

Using the concept for the cryostat described in the previous section, a variable temperature cryostat insert can be made for use with open-neck research or storage Dewars. Such a cryostat would have its own independent vacuum jacket to isolate the sample tube from the main reservoir and a helium valve to draw the liquid into the sample tube in a controlled manner. Such inserts are beneficial for introduction into the bore of a superconducting magnet located in a research Dewar. The magnet has its own support structure, so the insert can be removed without disturbing the magnet.

The insert itself may also support the magnet and eliminate the independent magnet support. The magnet determines the insert's isolation (bore) tube diameter, with the sample tube's diameter approximately 12.7 mm (0.5 in) smaller than the isolation tube. The space between the sample and isolation tubes is evacuated, and the capillary tube carrying the helium from the main reservoir into the sample chamber lies in that vacuum space.

Access to the capillary tube and vaporizer (with its associated heater and control sensor) is through a demountable indium (or solder) seal. The helium reservoir should be pressurized (with a simple pressure relief valve) to maintain the slight over-pressure needed to drive the helium through the needle valve, capillary tube, and heat exchanger into the sample tube. The most convenient place for such a valve is at the (common) exhaust of any vapor-cooled high-current magnet leads because this maintains the necessary flow of cold helium vapor through the leads.

Temperature variation is achieved in the same manner as the detachable-tail insert cryostat. It covers the range of about 1.8 K to 300 K in flowing vapor or down to 1.5 K in superfluid helium. Once again, operation below 4.2 K is achieved without pumping on the main reservoir containing the superconducting coil.

For systems that need to operate with liquid helium but for long periods above 80 K, an additional exchange gas type insert can be inserted into the sample tube. This

provides a smaller sample tube in a static gas environment, which allows heating the sample at the sample mount to temperatures above 80 K without increasing the helium consumption for the main reservoir. Therefore, when operating at the higher temperature range, the temperature control can be shifted to the heater at the sample mount while maintaining the vaporizer temperature between 5 K and 30 K. This usually requires the exchange gas pressure to be close to 1 mTorr and reduces the amount of heat needed to raise the temperature of the sample mount. Such systems can be operated at higher temperatures (up to 700 K to 800 K) if an appropriate sensor (such as a type E thermocouple) replaces the typical Cernox sensor used between 1.5 K and 300 K. This also requires a special heater at the sample mount to withstand (and reach) the higher temperatures. The magnet and the main helium reservoir will not sense the high temperature of the sample mount and can very often operate with the same helium consumption.

3. Continuous transfer cryostats

In many cases, it is preferable to eliminate the research Dewar with its own helium (or nitrogen) reservoir because of a lack of space or a desire for a more portable cryostat. For such applications, an efficient vacuum-insulated transfer line with a flexible section can carry the cryogen from a storage Dewar to a small cryostat. This arrangement is preferable to an in-line valve because it presents a lower heat input into the flowing cryogen.

The outer line has a flexible section 1.5 to 3 m (5 to 10 ft) long to provide more maneuverability, while the inner line can be made from 1.6 to 3 mm (0.063 to 0.13 in) diameter stainless steel tubing and is surrounded by MLI. Properly designed and located spacers keep the inner line concentric within the flexible outer line. The storage Dewar leg is usually made to match typical storage Dewars, with a 12 mm (0.5 in) diameter and a 1 to 1.5 m (40 to 60 in) length. The entire line is vacuum-insulated and has an evacuation valve to maintain a good vacuum (10^{-5} Torr) and a safety pressure relief valve to guard against cold internal leaks. With careful design and manufacturing techniques, the heat load on the inner line can be reduced to less than 300 mW for a typical unit (183 cm [6 ft] flexible section, 1.6 mm [0.063 in] inner line, 122 cm [48 in] storage Dewar leg, and 51 cm [20 in] cryostat leg). This line can be used for continuous cryogen transfer, so making it as efficient as possible is essential.

Two types of configurations are used with this transfer line. One unit provides a cold finger with the sample in vacuum, while the other unit places the sample in the path of flowing vapor.

The Beginner's Guide to Cryostats and Cryocoolers

i. Sample in vacuum

Figure 3.5 shows a simple cold finger cryostat that mates with the transfer line. The transfer line leg fits inside an o-ring compression seal at the top of the cryostat and delivers the cryogen to the inside of the cold finger. The cryogen exits through a concentric stainless steel isolation tube and cools a thermal anchor to which a radiation shield is attached. The cryogen eventually exits at a vent port away from the detachable seal for the vacuum jacket.

The outer (vacuum) jacket usually has a quick-remove elastomer seal allowing easy sample holder access. The radiation shield, cooled by the escaping vapor, may be bolted to the thermal anchor and is required for liquid helium use. The cryostat can also be used with liquid nitrogen as long as the flow control valve can be adjusted to reduce the flow significantly. A heater located at the cold finger allows temperature variation above 4.2 K (liquid helium) or 77 K (liquid nitrogen). Optical access to the sample is facilitated by adding windows to the vacuum jacket and holes (or windows) to the radiation shield. Evacuation and pressure relief valves and vacuum-tight electrical feedthroughs are usually located above the joint of the removable vacuum jacket to provide the necessary vacuum and wiring access to the cold finger.

Although such cryostats may operate in any orientation, the vertical position requires the least amount of cryogen at any specific temperature. Temperatures above 4.2 K can be obtained by reducing the liquid helium flow or adding heat at the cold finger wound heater. Temperatures below 4.2 K are obtained by either throttling the flow control valve and pumping at the vent port or by allowing helium to collect on top of the cold finger and reducing the pressure (at the vent port) with the flow valve closed. The latter mode usually produces a lower temperature (approximately 1.4 K). This system forms the basis for the Environment by Janis SuperTran-B cryostat.

ii. Sample in vapor

Figure 3.6 shows a cryostat that can be used with the same transfer line. The transfer line fits (horizontally) into a mating (female) bayonet connection at the top of the cryostat, and the cryogen is channeled through a capillary tube into a heat exchanger/vaporizer at the bottom of the sample tube. The cryostat shown in Figure 3.6 provides optical access through inner (cold-sealed) and outer (room temperature) windows. The cold vapor exits a vent (or pumping) port at the top of the cryostat and, in the process, cools a thermal anchor and the radiation shield attached to that anchor. The system operates similarly to the flow cryostat with detachable-tail Dewars (Environment by Janis SuperVariTemp), with the cryogen now continuously transferred from a storage Dewar.

The system was originally designed for use with liquid helium as the cryogen, but a newer version can also be used with liquid nitrogen. Operation below 4.2 K (down to 1.8 K) requires filling the sample chamber with liquid helium, closing the flow control valve, and reducing the pressure through the sample tube vent port. The flow valve can also be throttled while pumping at the sample tube vent port to operate continuously in a flowing vapor mode at approximately 3 K.

The liquid helium consumption of this system will generally be higher than that of the cold finger system (SuperTran-B) while using the same transfer line. This is likely because the helium has to travel through a capillary tube (usually about 30.5 cm [12 in] long), which undergoes at least two 90° bends, with associated heat loads due to radiation and flow turbulence. The bending path adds approximately 600 mW into the flowing cryogen, resulting in a total system consumption of about 1.5 L/h at 4.2 K but dropping below 0.5 L/h above 20 K. With its quick cooldown, portability, and ease of use, this can be a more desirable cryostat than a regular Dewar in some applications. This system forms the basis for the Environment by Janis SuperTran-VP cryostat.

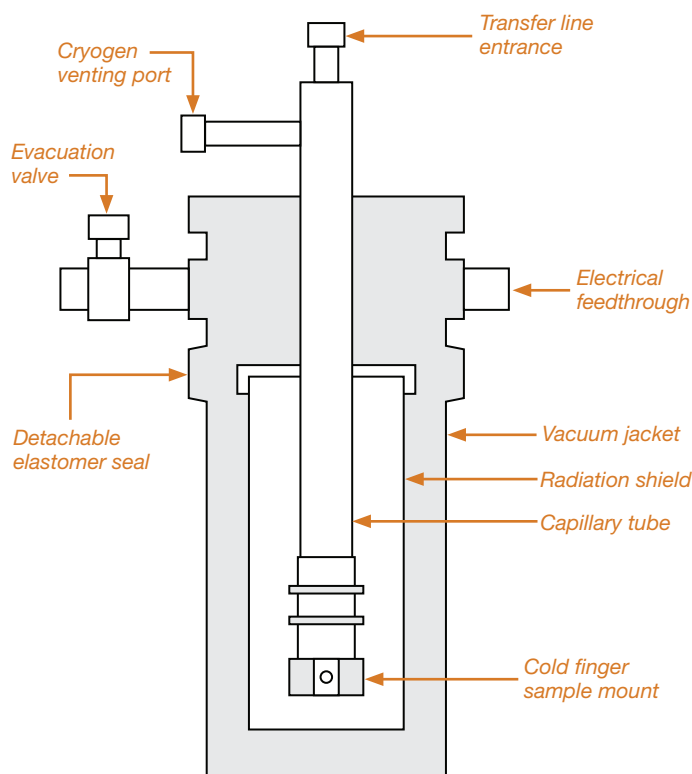

Figure 3.5: Continuous transfer cold finger cryostat

The Beginner's Guide to Cryostats and Cryocoolers

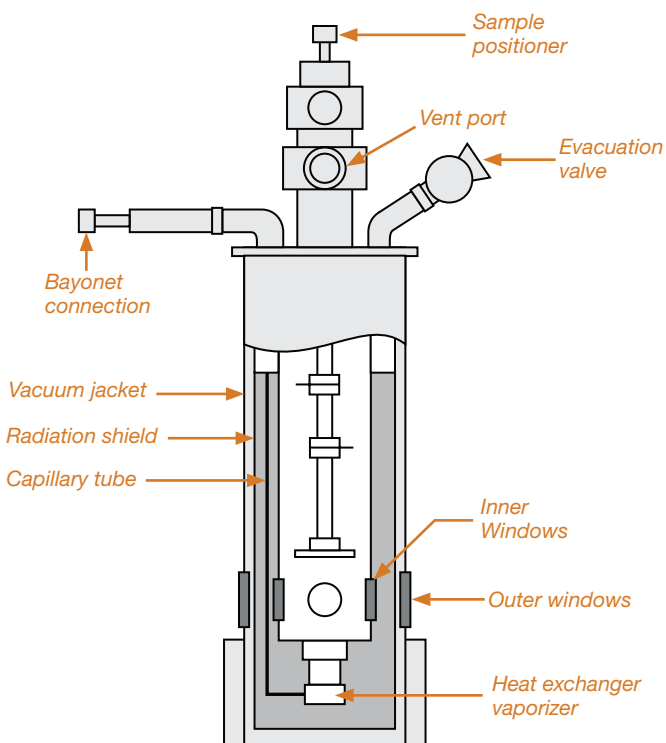

Figure 3.6: Continuous transfer sample in vapor cryostat

iii. Special microscopy systems

Special systems have been developed for experiments that require a minimum distance between a microscope objective and the sample. These systems are carefully designed to offer rigid, stable support for the sample as well as effective de-coupling from the incoming and outgoing cryogen lines. This results in a system with excellent spatial stability with a typical drift of 2 nm/min. These cryostats typically have a short height to fit under standard microscope objectives and a stable base to support the cryostat rigidly under the microscope. Figure 3.7 shows an example of a microscopy cryostat with separate helium entry and vent lines. This cryostat operates with the same high-efficiency transfer lines used for the other continuous transfer cryostat.

Access to the sample is usually through the top cover of the vacuum jacket. This cover has a small window very close to the sample (typically between 3 and 10 mm). These cryostats usually have a bottom window to allow transmission measurements. They are also supplied with extended top vacuum jackets and radiation shields for insertion into the bore of a superconducting magnet, an electromagnet, or permanent magnets. X-y-z nanopositioning stages inside the cryostat allow precise cold finger and attached sample maneuvering.

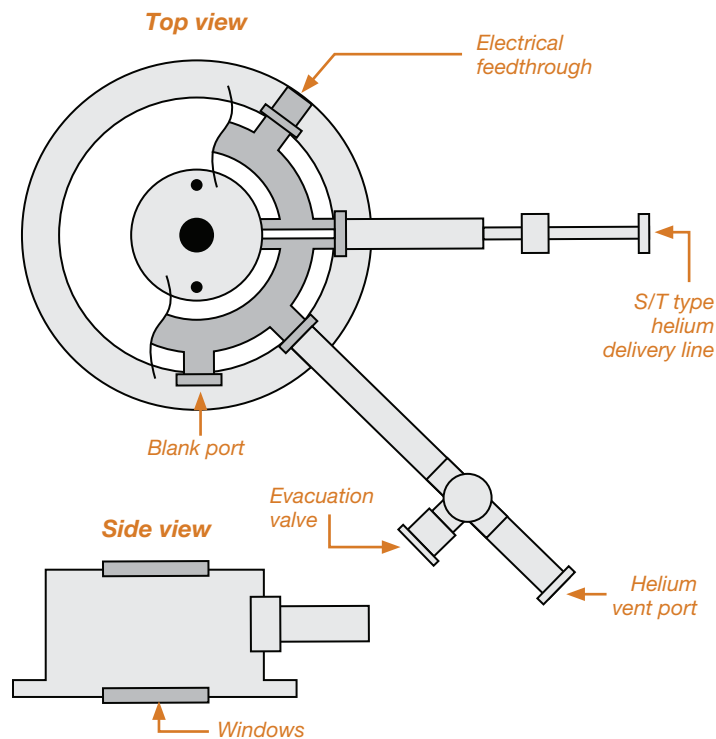

Figure 3.7: Continuous transfer microscopy cryostat

4. Closed-cycle refrigerator systems

Where the handling of liquid cryogenics is undesirable or when obtaining them is difficult, a mechanical (closed-cycle) refrigerator can be used. The most common commercially available refrigerators make use of two-stage Gifford-McMahon (G-M) or newer pulse tube (PT) coolers that use high-purity (99.999%) helium gas as the working fluid (Ref. 2, Ch. 2).

In these units, the cold head is separated from a compressor by a couple of flexible high-pressure tubes that circulate the compressed helium in and out of the cold head. This enables easy handling of the 8 kg to 15 kg cold head while the heavy (approximately 65 kg 180 kg) compressor is in a fixed location nearby (about 3 m to 20 m [10 to 66 ft]). The cold head for the G-M coolers contains displacers (pistons) that compress and expand the helium gas inside the two stages of the cold head. It also includes the regenerators (reverse-flow heat exchangers) that are critical for cooling the incoming gas, resulting in the ultimate cooling of the second stage. These regenerators are usually made from materials with poor thermal conductivity, high specific heat, and a large surface area to enable them to absorb the heat from the incoming warm helium gas and give up heat to the colder exiting helium gas. The PT coolers have the advantage of not having any displacers or other moving parts, which makes them less likely to require maintenance.

The Beginner's Guide to Cryostats and Cryocoolers

The compressors are typically charged to high pressures (220 psi to 300 psi). They connect to the cold heads through stainless-steel flexlines and special Aeroquip fittings that allow quick attachment and detachment of the lines without permitting any air into the high-purity helium working gas. The G-M coolers have inlet and exhaust valves in the cold head that are actuated by a rotary mechanism. The displacers may be driven either pneumatically or by the synchronous motor that drives the valves. The PT coolers with no displacers in the cold head are supplied with a rotary valve and motor that may either be located at the top of the cold head or separated by a semi-flexible line about 60 to 100 cm (2 to 3.3 ft) away. The motor can optionally be electrically isolated from the cold head to reduce the electrical noise to any cryostat attached to the cold head. The motors must be located in a low magnetic field (500 G or less) not to slow their movement and reduce the cooling power. The cold head itself should also be located in a relatively low magnetic field (1000 G or less) not to risk affecting the performance of the regenerators and reduce the cooling power of these coolers.

The motor and displacer movement frequency in the G-M coolers is about 2 Hz to 3 Hz and varies with the frequency of the available AC signal (usually 50 or 60 Hz). The lower frequency (50 Hz) typically results in a lower refrigeration capacity at the first stage but does not affect the cooling capacity at the second stage, except for the 10 K coolers. In PT coolers, the motor frequency is approximately 1 Hz to 2 Hz, and the cooling power is not affected by the frequency of the AC signal. The motor and associated piston (displacer) movement in the G-M cold heads results in a certain level of vibration transmitted to the cold finger and outer body of the cold head. The PT coolers' lack of moving parts results in fewer vibrations transmitted to the outer body of the cold head, but the cold stages will still have some vibrations associated with the pressure variation during the cooling cycle. These vibrations (approximately 4 μm) are typically lower than the vibrations of a G-M cooler by a factor of 2 to 4. Fortunately, these vibrations are tolerable for many experiments at low temperatures, and special vibration isolation techniques are available to reduce these vibrations to much lower levels. These techniques typically involve using flexible copper braids or an exchange gas mechanism coupled with rigid sample mounting, resulting in less cooling power and higher base temperature at the sample.

In general, the two-stage G-M coolers are available in two categories. The smaller units have a base temperature of 8 K to 10 K with a typical cooling capacity of 2 W refrigeration capacity at 20 K, or 2 W at 10 K, up to 9 W at 20 K (or higher). This cooling capacity is satisfactory for most experiments conducted in a typical low-temperature laboratory. The second category of G-M coolers reach temperatures of less than 4.2 K with various cooling powers ranging from 0.1 W up to 1.5 W (as of this date) at 4.2 K, with base temperatures reaching below 3 K.

These units also require very little maintenance to the cold head or compressor. Typically the compressor filter (activated charcoal adsorber) must be replaced after 9,000 to 10,000 h of use. The filter removes all traces of oil vapors from the helium gas returning to the cold head, and if not replaced could result in some oil vapors contaminating the cold head and freezing there. In some systems, replacement of the displacers and associated gasket seals is also recommended after this period of operation. An elapsed-time meter at the compressor keeps track of the total operating time.

Two-stage PT coolers are also available in two categories (10 K and 4.2 K) with the latter in much more demand. The 4.2 K PT coolers are also available in various cooling powers from 0.25 W up to 1.5 W (as of this date). The PT cold heads require maintenance every 20,000 h with potentially even more extended periods (up to possibly 30,000 h), but there is currently not enough data on these relatively new coolers to guarantee that longer maintenance timeframe. One final thing to note is that the PT cold head, unlike the G-M head, cannot operate in an inverted position. The PT cold head can be tipped approximately 15 to 30° from the vertical access before losing some cooling power.

The compressor also contains a heat exchanger that dissipates heat generated when the helium gas is compressed. Both water-cooled and air-cooled systems are available, with air-cooled being slightly more expensive. Safety protection switches are installed at the compressor to turn it off if the temperature gets too high. This could happen due to high water temperatures, too low a cooling water throughput, or too high an ambient temperature. Other protective switches turn the compressor off if the pressure is too high or too low, and a safety pressure relief valve protects against system overcharge. The compressor and cold head must be cleaned (using 99.999% pure helium gas), and the system re-charged if it gets contaminated (with air, water vapor, or oil) or if the pressure drops too low (usually below 30 psi). In general, the power requirements for the various refrigerators vary between approximately 2 kW for the 10 K systems up to about 8 kW for the 4 K systems, with AC power input ranging from 220 VAC 1-phase (for 10 K systems) up to 400 VAC or 470 VAC 3-phase options for the 4 K systems.

The Beginner's Guide to Cryostats and Cryocoolers

The construction of the cold head lends itself naturally to a cryostat with a cold finger configuration. Indeed these refrigerators are also used (with appropriate baffles and condensing fin arrays) as cryopumps in vacuum chambers requiring clean environments. When used as variable temperature cryostats, two general categories are obtained, with the sample in vacuum or sample in an exchange gas column cooled by the two stages of the refrigerator. These two categories are described in the next sections.

A. Cold finger cryostats

Figure 4.1 shows the cold head of a (10 K) closed-cycle refrigerator with mechanically driven pistons attached to a vacuum jacket and adapter containing electrical feedthroughs, an evacuation valve, and a safety pressure relief valve (not seen in the drawing).

The vacuum jacket surrounds the cold head, consisting of the second refrigerator stage (that acts as a cold finger/sample mount) and the first stage, which is attached to a radiation shield surrounding the cold finger. This arrangement provides a temperature of 8 K to 10 K at the cold finger, while the radiation shield is cooled to 60 to 80 K by direct contact with the first stage. The Figure shows the cold finger pointing upwards, making it only appropriate for G-M-type coolers because, as mentioned earlier, PT coolers cannot operate in this orientation. A heater attached at the cold finger allows temperature variation up to room temperature. Should higher temperatures be required, a special insulating stage can be added at the second stage. The insulating stage is needed because the cold head is usually not designed to withstand temperatures much higher than room temperature. In this case, it is advisable to have a protection circuit to prevent the second stage from reaching these higher temperatures and causing damage to the cold head.

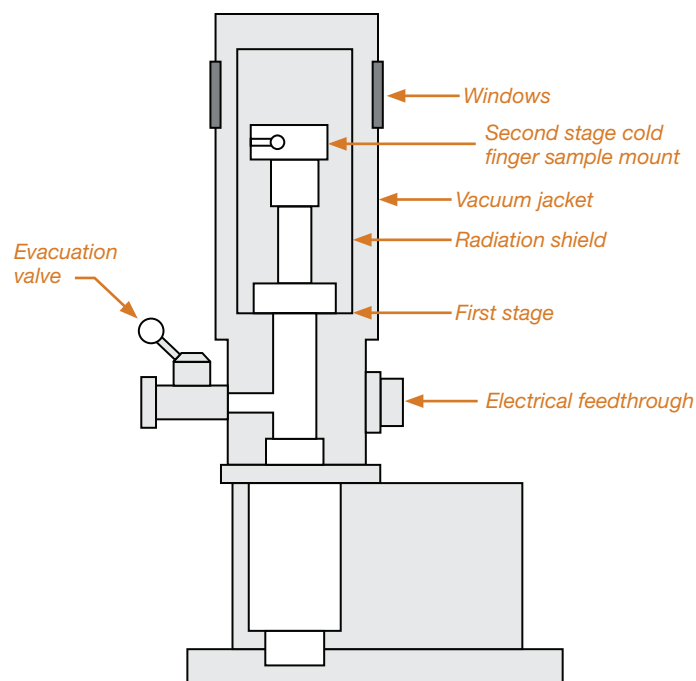

Figure 4.1: Closed-cycle refrigerator cryostat

Figure 4.2 shows a PT cold head in a cold finger configuration where the cold head is oriented upright (required for PT coolers). The designs shown in Figures 4.1 and 4.2 include a simple arrangement providing optical access to the sample mount. These windows can be eliminated when optical access is not required. The radiation shield and vacuum jacket can be manufactured closer to the cold finger if a more compact configuration is needed. The cold finger can be extended for very tight spaces using a long thin OFHC copper extension to the cold finger. The radiation shield and vacuum jacket can then also be narrowed down to fit inside small spaces (such as a pole gap of an electromagnet). The lowest temperature attained at the end of such a sample mount may be one (or more) degrees higher than the temperature of the cold finger, depending on the details of the setup in question.

A typical system reaches its lowest temperature in about 1 h. That time is affected by the size of the sample holder and the sample attached to the cold finger. Some units exhibit a small (0.1 to 0.5 K) temperature fluctuation at the lowest achievable cold finger temperatures. The change is related to the displacer motion (and associated thermodynamic cooling cycle) inside the second stage and can be improved by using an automatic temperature controller and sensor to keep the temperature slightly higher than the lowest-attainable temperature. It can also be minimized or reduced to a few mK by adding specially-designed stages to the cold finger.

The Beginner's Guide to Cryostats and Cryocoolers

As with any other cold finger (sample in vacuum) cryostat, it should not be assumed that the sample is exactly at the same temperature as the cold finger. For this purpose, attaching a sensor to the sample can help obtain a more accurate temperature measurement.

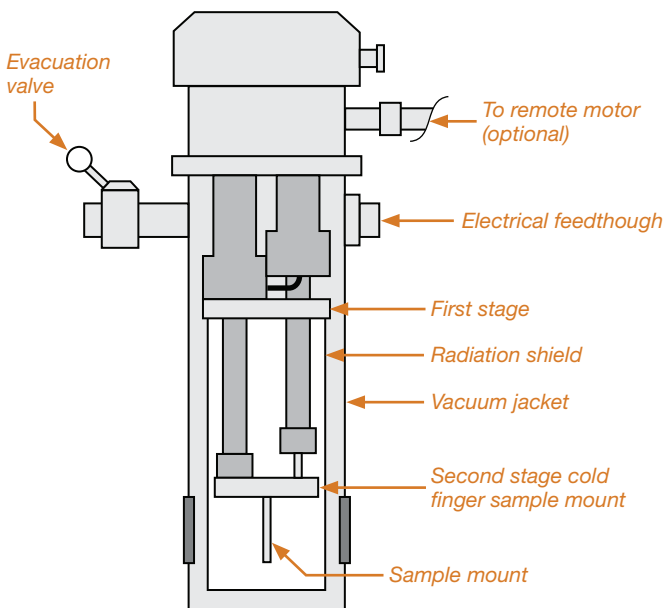

Figure 4.2: Pulse tube cooler cryostat

B. Exchange gas cryostats

Figure 4.3 shows the cold head of a 7 K or 10 K G-M closed-cycle refrigerator, with pneumatically driven displacers, attached to an exchange gas sample chamber surrounded by a radiation shield and vacuum jacket.

The lower portion of the sample tube is formed from an isothermal copper surface that is cooled by direct contact with the refrigerator's second stage. The radiation shield is made from aluminum or copper and is cooled by direct contact with the first stage. It surrounds the main length of the sample tube and is anchored to a point at the upper portion of the sample tube to intercept the conductive heat load coming down the sample tube from room temperature.

The sample is attached to a copper sample mount supported by a long thin-walled stainless steel tube with baffles, which emerges at the top of the cryostat. Electrical access to the sample area is located at the top of the sample positioner, while electrical access to the second stage (inside the vacuum jacket) is located near the bottom of the vacuum jacket. Heaters and control sensors may be attached to the second stage of the refrigerator or the sample mount. The temperature may be controlled at either of these two points, with control at the second stage being a little slower because of the large mass attached to that stage. With about half an atmosphere of helium exchange gas in the sample tube, the sample and its holder can be cooled or heated indirectly through the second stage (and its heater). Controlling the temperature at the sample mount is quicker because of its smaller mass. Still, it requires good thermal anchoring of the sample to the sample mount to ensure that the sample is at the same temperature as its mount, especially when heated.

The pressure inside the exchange gas tube is not as critical as in the case of a liquid helium Dewar, where helium consumption is a concern. A properly designed system can achieve a temperature of about 10 K at the sample. This arrangement is desirable because it permits quick sample interchange (through the top-loading configuration) without heating the entire cold head and breaking its vacuum, as required in the cold finger configuration. The exchange pressure must be brought up to atmospheric pressure to prevent air from entering the sample tube while changing samples. The penalty for this arrangement is the higher ultimate temperature (about 3 to 5 K higher) and added cost of the exchange gas system.

Another advantage of this configuration is that the sample holder can be decoupled from the vibrations generated by the drive mechanism for the displacers and valves inside the cold head. This is done by adding a vibration isolation bellows and a support flange between the sample positioner and the top of the sample tube. The flange can be rigidly bolted to a stationary stage, which supports the sample rod and the bellows. The sample rod and holder, along with the radiation baffles, should make no contact with the walls of the sample tube and should be supported vertically from the stationary stage.

The Beginner's Guide to Cryostats and Cryocoolers

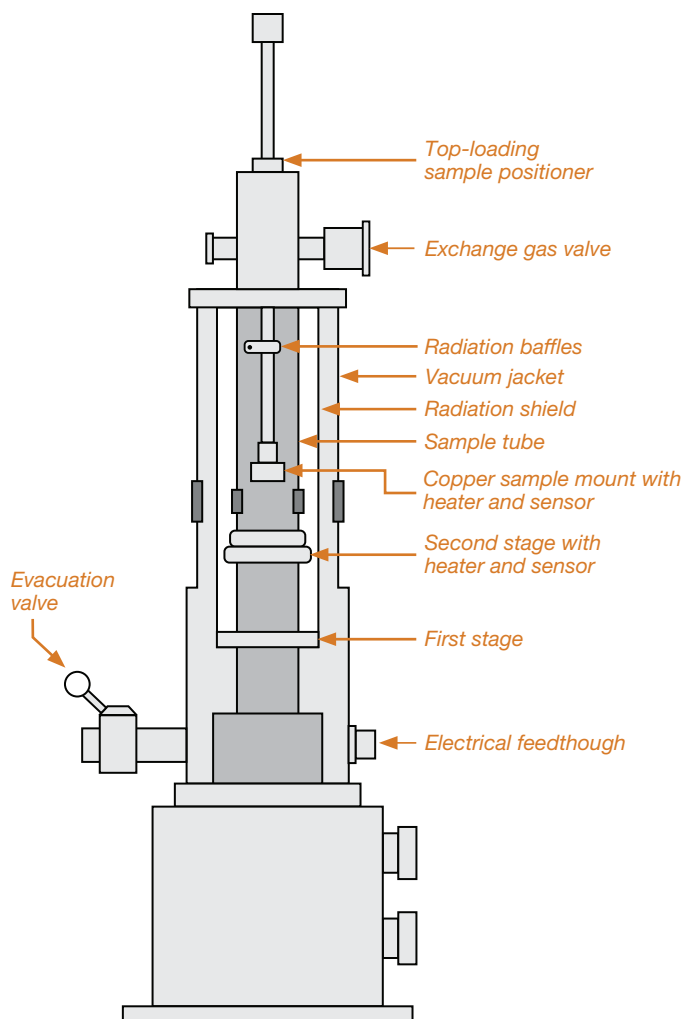

Figure 4.3: Exchange gas refrigerator cryostat

Figure 4.4 shows another configuration for an exchange gas cryostat that maintains the cold head upright. This geometry can be much more convenient for the end user, albeit a little more expensive to manufacture. In this specific example, a PT-type cold head is used, and the two stages of the cold head are thermally anchored but mechanically decoupled from the exchange gas sample tube where the sample rod is inserted. The decoupling is done with specially designed OFHC copper flexible thermal links having relatively large thermal conductance to ensure the sample reaches a low enough temperature (typically 4.5 K or less in a 4 K cooler).

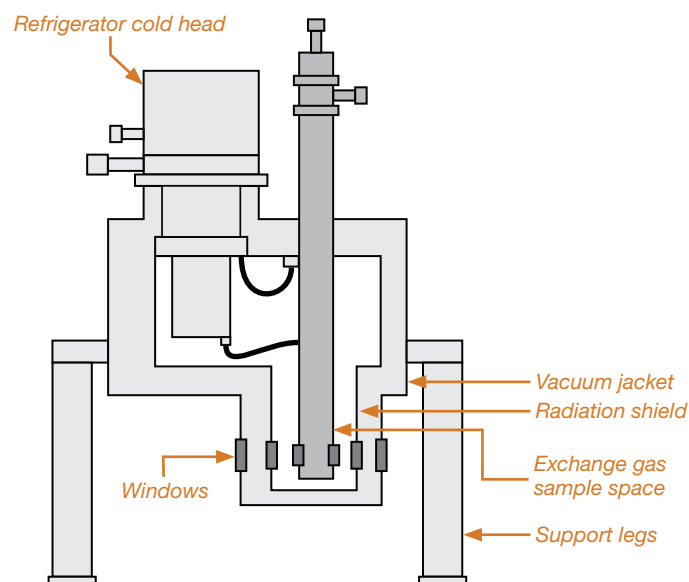

Figure 4.4: Vibration-isolated sample in exchange gas

C. Vibration-isolated cryostats

With the increasing interest in cryogen-free systems based on mechanical coolers, there is also the desire to eliminate the vibrations associated with these systems. Two previously mentioned examples locate the sample in an exchange gas environment. Figure 4.5 shows an example of such a cryostat with a new cold finger that is mechanically decoupled from the body of the main cold head. In this case, the thermal link to the cold finger (and surrounding radiation shield and vacuum jacket) is made through helium exchange gas. The cryostat requires rigid support on a vibration-isolated table, and the cold head itself needs to be independently supported. A flexible bellows links the cold head to the cryostat while isolating the cryostat from the vibrations. This design can also be modified into a microscopy-type cryostat where the cold finger is positioned very close to the outer window. The cooling power of the cold head is significantly reduced in these cryostats; the lowest temperature can be several degrees higher than the base temperature of the cold head.

The Beginner's Guide to Cryostats and Cryocoolers

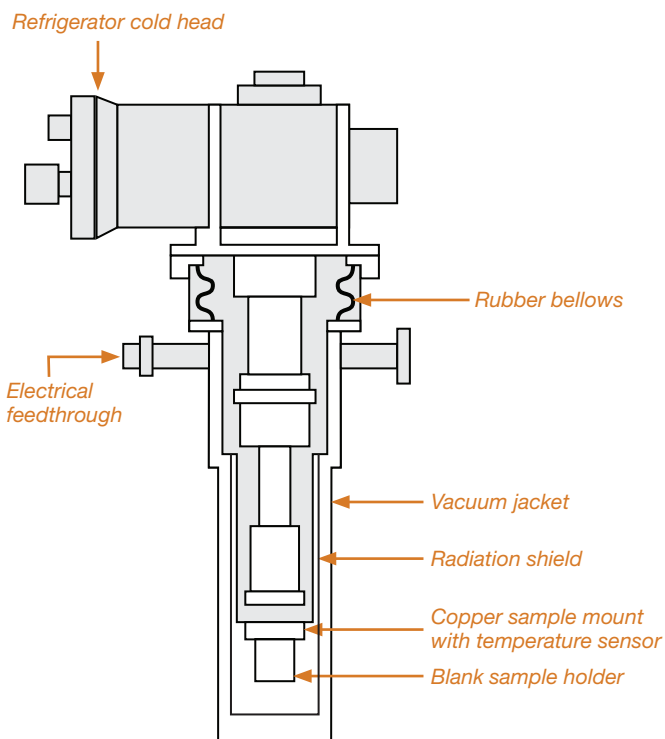

Figure 4.5: Vibration-isolated G-M cooler

5. Experimental techniques and data

The final configuration for a variable temperature cryostat generally involves appropriate thermometry, automatic temperature control, sample attachment, and system cooldown. The following concentrates on commercially available instrumentation, general considerations for ensuring efficient cooldown, and the necessary anchoring techniques to achieve the desired sample temperature.

A. Cooldown of helium cryostats and samples

The enthalpy (total heat) of common materials used for constructing cryostats (stainless steel, copper, aluminum, etc.) drops rapidly with decreasing temperature. Because of this, along with the low cost of liquid nitrogen and its high heat of vaporization (relative to helium), liquid nitrogen is the natural choice to cool the Dewar from room temperature to 77 K.

Once this is done, the liquid nitrogen can be removed (from the helium reservoir) by inserting a tube that reaches the reservoir bottom and blowing the nitrogen out by over-pressurizing the reservoir. As mentioned earlier, it is critical to remove all liquid nitrogen from the helium reservoir before transferring liquid helium because the heat capacity of solid nitrogen is quite large (an order of magnitude greater than for copper). Even a couple of inches of liquid nitrogen remaining in the bottom of the helium reservoir requires large amounts of liquid helium to cool to 4.2 K and allow

helium to accumulate. The cooldown to 77 K in simple reservoirs takes less than 1 h. However, if a large mass (e.g., 4 K radiation shield or large sample) is attached to the reservoir, this process may take several hours and is best monitored by a sensor attached at the end of this mass.

Once all the liquid nitrogen is removed, liquid helium can be transferred using an appropriate helium transfer line. The vacuum jacket of the transfer line should be periodically evacuated, and the insulated storage Dewar leg should extend practically to the bottom of the storage Dewar. The delivery end can be either fully insulated or have a short extension tip (of a few inches) and should deliver the helium to the lowest point in the helium reservoir. The helium transfer must start at a very low rate and be maintained at that rate until the entire contents of the helium reservoir (including any attached mass) are cooled below 20 K. This takes advantage of the cold helium gas enthalpy as it rises and escapes from the top of the cryostat to cool the reservoir and its contents. A poor helium transfer, which does not use this enthalpy, can use ten times more liquid to cool the Dewar from 77 to 4.2 K. A poor (fast) helium transfer can also result in a quick filling of the helium reservoir, even while most of the reservoir is at a temperature above 20 K. However, this usually results in the liquid helium quickly boiling off within the next hour as it cools the rest of the reservoir to 4.2 K.

Any sample being cooled should preferably be done at the same time as the helium reservoir. When the sample is inside the reservoir, it gets cooled (along with the reservoir) by direct contact with the helium vapor. If, however, the sample is on a cold finger in vacuum, it should be thermally anchored exceptionally well to the cold finger. This produces faster cooldown times and a lower ultimate temperature at the sample. If possible, a sensor should be placed at the sample (or its holder) to monitor the sample temperature. This sensor would be in addition to any existing at the cold finger itself.

When two pieces are in contact (in vacuum), a thermal (boundary) resistance always develops across the surface interface. This usually results in a temperature difference between the two pieces, especially if one is cooled by contact with a cryogen (or a cooling gas) while the other is only being cooled through surface contact with the first piece. The temperature difference that develops is proportional to the thermal resistance and the heat load on the second piece. The thermal resistance can be decreased by increasing the contact pressure between the two pieces and employing conductive epoxies or greases. In some applications, a thin layer of indium is used to increase surface contact.

The Beginner's Guide to Cryostats and Cryocoolers

The thermal resistance between two components pressed together is usually difficult to measure because it depends on the condition of the surfaces in contact. The surfaces should generally be very clean and polished. Typical values for boundary resistances of copper-to-copper surfaces with a load of 45.4 kg (100 lb) are about 100 K/W at 4.2 K and 3 K/W at 77 K. Equivalent resistances for stainless steel are 185 K/W at 4.2 K and 3.8 K/W at 77 K. Gold plating copper surfaces can decrease their boundary resistance by 20 times at 4.2 K (see Ref. 1, Ch. VII & Ref. 2, Ch. 4).

When a sample is attached to a cold finger, good thermal contact is necessary between the two to reduce the heat load into the sample as much as possible. Therefore, wires running to the sample should be wrapped around the cold finger and thermally anchored to it (using a conductive epoxy) before reaching the sample. Surrounding it with a radiation shield anchored directly to the cold finger can also reduce the radiational heat load on the sample. All these precautions minimize the temperature difference between the sample and the cold finger.

B. Thermometry and temperature control

Many types of commercially available temperature sensors can be used at low temperatures. The most commonly used are silicon diodes, Cernox resistors, ruthenium oxide resistors, platinum resistors, gallium (and gallium-aluminum) arsenide diodes, and the less widely used germanium resistors, carbon-glass resistors, and rhodium-iron resistors. These sensors tend to retain their characteristics with repeated thermal cycling and can be reliably calibrated. Silicon, gallium arsenide, and gallium-aluminum arsenide diodes are usually activated with a constant current source, and the voltages developed vary (in a reproducible manner) with temperature. Platinum and rhodium-iron resistors are also activated with a constant current source, and their resistance varies with temperature. Cernox, ruthenium oxide, germanium, and carbon-glass resistors must be activated with a variable current source because their resistances vary over several orders of magnitude as the temperature changes. Thermocouples consisting of a pair of dissimilar metal wires, soldered or welded together, are also useful when a small sensor is required. They generate an emf, which varies with temperature and is used as a basis for measuring the temperature. They are generally not as sensitive as other available sensors at 4.2 K (typical sensitivity for a gold-iron vs. chromel thermocouple is 10 μ V/K), and slight differences in the wire composition can cause significant deviations from the standard curves. We will therefore limit this discussion to the diode and resistance sensors listed above.

1. Sensor installation

Before discussing the various types of cryogenic sensors, it is important to note one common characteristic of most. Even though manufacturers make every effort to establish a good thermal link between the body of the sensor and the internal temperature-sensing element, 70 to 80% of the actual temperature sensing is through the electrical leads. While this does not present any difficulties if the sensor is in liquid helium or flowing vapor (where both the leads and the body are immersed in the vapor), it can be a source of error when the sensor is attached to a cold finger in vacuum. In vacuum, the leads running down from room temperature to the cold end of a helium cryostat can easily carry enough heat to result in a sensor reading of 10 K above the actual temperature of the surface to which it is attached. It is, therefore, crucial to remove any “Teflon spaghetti” covering the sensor leads as they exit from the body, wrap them tightly around the cold finger, and thermally anchor them with a loaded epoxy (such as Stycast 2850). This must be done without any electrical shorts between the leads and the cold finger.

The leads going to room temperature should preferably be manganin or phosphor bronze—i.e., some alloy of low thermal conductivity. Typically, 32 AWG wires should be used, and they should be spiraled as they travel to the room temperature end to increase their effective length and reduce any heat they transmit. Anchoring these leads to an intermediate cold stage (at 80 K) to intercept the large heat load from room temperature is also important. A quick calculation (using the tables at the end of this chapter) is helpful to ensure that the cryostat has enough cooling power to handle the heat load due to these leads. This becomes much more important below 4.2 K, where the heat capacities are very small. A small heat load can easily result in a relatively significant rise in temperature or an erroneous temperature reading.

i. Silicon diodes

Silicon diodes have become the most common type of sensor used in the temperature range of 1.5 K to 300 K (or 500 K). When activated with a 10 μ A constant current source, they offer a voltage of about 1.7 V at low temperatures, dropping to about 0.5 V at room temperature. Their sensitivity ranges between approximately 25 mV/K below 20 K to 2.3 mV/K above 70 K. Because they are activated with a constant current, they are the obvious choice for use with an automatic temperature controller. Their main disadvantage is that their voltage changes significantly in a magnetic field below 77 K. Therefore, they are unusable for temperature measurement or control even with a low magnetic field of 1 T.

The Beginner's Guide to Cryostats and Cryocoolers

These sensors are usually provided in a four-wire configuration, which eliminates the effect of the potential drop across the wire leads connected to the sensor. When these leads are thin copper wire (32 AWG/0.008 in diameter), the potential drop along a ten-foot length, with a 10 μ A current source, is negligible compared to the sensor voltage—so a two-wire arrangement is sufficient. Even if 32 AWG phosphor bronze wires are used (resistance of 1 Ω /ft), the potential drop for a 3 m (10 ft) wire will still be about 1000 times smaller than the sensor voltage.

One significant advantage of silicon diode sensors is that they are usually available embedded in a small (about 0.3 in diameter) copper disk with its leads anchored to that disk. This configuration allows quick connection of the sensor to a cold finger surface (in vacuum) by bolting the sensor with a #4-40 or M-3 screw. No other careful anchoring of the leads is required.

Finally, silicon diodes are now commercially produced with temperature characteristics that deviate no more than 0.5 K to 1 K (below 100 K) from a standard curve. This curve is usually stored on a PROM in the temperature controller, which can then be used with any of these diodes. If better accuracy is needed, the diode can be calibrated, and its calibration can be stored in the controller.

ii. Gallium arsenide diodes

GaAs and GaAlAs diodes are also excited with a constant current (10 or 100 μ A), but they cannot be mass-produced with temperature characteristics that conform to any standard curve. They can still be calibrated and used with a simple (constant current) temperature controller. Their only advantage over silicon diodes is that they can be used in low magnetic fields (1 to 2 T) because their voltage does not vary significantly with the applied field.

iii. Platinum resistors

Platinum resistance sensors are generally used between 60 K and 500 K, where the resistance increases at a relatively constant rate of about 0.4 Ω /K. They are occasionally used down to about 20 K, but their sensitivity drops to about 0.08 Ω /K. Their ceramic outer case allows these sensors to be used up to 600 °C. However, it is difficult to find a technique that thermally anchors the sensor and its leads at lower temperatures that will also withstand higher temperatures.

Platinum sensors are usually activated with a constant current, and the typical 100 Ω (at 0 °C) sensor follows a standard curve down to 60 K to within a couple of degrees. Those sensors are also useful (above 30 K) in large magnetic fields (14 T or higher) due to their small field-induced change in resistance.

iv. Cernox® resistors

These thin-film resistors were developed around the end of 1994 and are used extensively in low temperatures (down to 1.4 K to 4.2 K) and high magnetic fields (up to 19 T). They have largely replaced the older carbon-glass resistors and, to some extent, the older germanium resistors that are not suitable for use in a magnetic field. They have excellent sensitivity at 4.2 K (approximately 1100 Ω /K), but their sensitivity drops by one order of magnitude at 10 K and by more than two orders of magnitude at 77 K.

Special types have been developed for use down to He-3 or lower temperatures, but their magnetic field dependence makes them less useful in that temperature range (ruthenium oxide becomes the better choice). These resistors also do not follow a standard curve and require individual calibrations for each sensor for accurate temperature measurement. They are commercially available in the same configuration as silicon diode sensors (see above), which makes them easier to install in a cryostat. They can also be calibrated and used up to 420 K, although, as mentioned earlier, their sensitivity drops significantly (down to -0.09 Ω /K). They are supplied with a four-wire configuration and require variable current excitation to maintain reasonable accuracy and prevent self-heating at the lowest temperatures (below 4.5 K).

v. Ruthenium oxide resistors

These thick-film sensors are useful for high magnetic fields and especially for very low temperatures (between approximately 25 mK and 20 K). They can also be produced commercially, with temperature characteristics that deviate no more than 10 mK at 50 mK to 0.6 K at 20 K from a standard curve. This curve is usually stored in the temperature controller, which can then be used with any of these sensors. If better accuracy is needed, the sensor can be calibrated, and its calibration can be stored in the controller. Their resistance increases significantly at lower temperatures, requiring a variable current source and current reversal and averaging to obtain accurate measurements and avoid self-heating.

vi. Germanium resistors

These sensors are always supplied in a four-lead configuration, labeled for current and voltage. Installation of these sensors requires careful thermal lead anchoring, as discussed earlier. Their resistance decreases with increasing temperature, up to 100 K, where the curve starts slowly turning—limiting the usefulness of these sensors to 100 K or less. One class of sensors is commercially available for use between 1.5 K and 100 K, while another class is used for lower temperature ranges (6 K to 0.3 K or 0.05 K). Their resistance changes by several orders

The Beginner's Guide to Cryostats and Cryocoolers

of magnitude, requiring a variable current source. When measured properly at the appropriate current and with current reversal to eliminate thermal EMFs, they can be a very precise sensor because of their excellent reproducibility. Special temperature controllers have been developed for these sensors that provide the necessary variable excitation current. They tend to be slightly more expensive than the equivalent controllers for silicon diodes or platinum resistors. The resistance of these sensors varies significantly with any applied magnetic field, so they cannot be used as sensors in those applications.

vii. Carbon-glass resistors

These sensors are primarily used in high magnetic fields due to the small change in resistance with applied field. They are supplied in a four-lead configuration, similar to the germanium resistors, and they also require careful lead anchoring for accurate temperature measurement. Their good temperature reproducibility and small (orientation-independent) magnetoresistance have made them the best thermometry choice in any magnetic field. SrTiO₂ capacitor sensors exhibit smaller (relative) magnetic field dependence but suffer from poor reproducibility with temperature cycling. Cernox's better sensitivity over the useful temperature range has reduced the use of older carbon-glass sensors.

viii. Rhodium-iron resistors

These sensors offer a monotonically increasing resistance with temperature, with a typical sensitivity of 0.17 Ω /K (between 100 K and 300 K), dropping down to about 0.08 Ω /K at about 25 K. They are activated with a constant current source and can be used between 1.5 K and 300 K (or up to 800 K). Their resistance varies linearly with temperature between 100 K and 300 K, and they follow a standard curve to within a couple of degrees in this range. They are useful in small magnetic fields (1 T or less) because the typical change in resistance at 4.2 K in a 1 T field is equivalent to about 0.08 K.

ix. Thermocouple temperature sensors

Thermocouples are generally made from two wires of different materials that generate a potential difference between the two wires when the two ends of the wires are at different temperatures. Typically two ends are spot welded together and held at the cold region of the cryostat and then travel (preferably uninterrupted) to a hermetically-sealed feedthrough at room temperature. In general, thermocouples do not offer very good temperature accuracy below 40 K and are primarily used when the system operates at higher temperatures (approximately 800 K). A very useful thermocouple is type E (Ni-Cr alloy and Cu-Ni alloy), which can be used in the entire temperature range

(40 K to 800 K) because it is available in a configuration that can be reasonably thermally anchored. While platinum sensors may offer better temperature accuracy, they are challenging to thermally anchor across this entire temperature range. Other useful thermocouples include type K (Ni-Cr and Ni-Al alloy) and gold-iron thermocouples (useful at lower temperatures). In general, thermocouples are not a good choice for thermometry at cryogenic temperatures and are used due to their practical ability to cover a wide temperature range, albeit with accuracies of a few degrees in the entire range.

2. Automatic temperature controllers

Commercially available temperature controllers designed to work with variable temperature cryostats from 1.5 K to 300 K (up to 800 K) generally fall into two categories. The simpler ones use a constant current source designed to work with silicon diodes, platinum resistance sensors, rhodium-iron resistance sensors, and GaAs or GaAlAs diodes. The silicon and platinum sensors can be obtained with standard calibrations that are stored in the controller, resulting in a temperature reading that is accurate within a few degrees (or better), depending on the temperature range. Such configurations are adequate for many experiments that do not require extremely precise temperature readings. For applications requiring a more accurate temperature measurement, the sensors are calibrated, and the calibration is stored in a PROM in the temperature controller. The controller then uses an appropriate interpolation scheme for that sensor and provides an accurate temperature readout (to better than 0.1 K). Most of these controllers have inputs for two to four sensors, making them very convenient for temperature control with one sensor and simultaneously reading (or displaying) the temperature at other points in the cryostat. A common configuration includes a standard-curve sensor for temperature control and a calibrated sensor for precise sample temperature measurement. When a standard-curve sensor is unavailable (e.g., GaAs diode), both sensors must be calibrated, and the calibrations stored in the temperature controller.

Digital temperature controllers have become the norm in most laboratories, although a few analog ones may still be available. Digital controllers usually display the temperature directly in Kelvin (or some other units), with options for displaying the voltage or resistance. Some of these controllers can also be used with thermocouples. More sophisticated controllers have special circuits that allow them to be used with any of the abovementioned sensors. In particular, they can be used with Cernox, ruthenium oxide, germanium, and carbon-glass resistance sensors. These circuits can change the excitation current for the sensor as well as use current reversal plus average measurements to cancel thermal EMFs as the temperature

The Beginner's Guide to Cryostats and Cryocoolers

and resistance of the sensor change. The accuracy of the resistance measurements can reach $\pm 0.01\%$ or better, depending on the range involved.

The majority of these temperature controllers offer three-term (PID) control. These three functions, Known as gain (proportional), reset (integral), and rate (derivative), can be set by the user. In addition, they have two or more heater output ranges, which determine the maximum amount of heat the controller can send to a cryostat heater. This output usually varies between 0.1 W and 50 W, with higher outputs needed for larger systems at room temperature or above. Users choose a setpoint (voltage, resistance, or temperature desired) that is compared with the actual sensor signal (voltage, resistance, or temperature). The difference (deviation) between these two signals is usually amplified (via a deviation amplifier), and if the setpoint temperature is higher than the sensor's temperature, the controller heats the cryostat heater. This heat counteracts the cooling power of the cryostat at the desired temperature. The heat output of the controller is proportional to the amplified deviation signal (difference between the setpoint and temperature sensor) within a specific range called the proportional band region. Therefore, once the top of this range is reached, the heater output is sending full power. The gain setting changes the deviation amplifier gain and determines the width of the proportional band (bandwidth increases with lower gain). A combination of sensor sensitivity and gain setting determines the heater output from the controller as a function of deviation (in kelvin) from the setpoint.

A low gain setting is required at lower temperatures, where the heat capacities are small. This lower setting sends a smaller amount of heat for a specific temperature deviation. As the temperature increases and the heat capacity of the cryostat increases, a higher gain setting is required. This higher setting sends a larger amount of heat for the same temperature deviation. If the gain setting is too high, it can cause the temperature to overshoot the setpoint and develop temperature oscillations in the system.

The gain (proportional) circuit should result in the controller giving out zero power when the deviation from the setpoint is zero. At temperatures above the lowest achievable cryostat temperature, a certain fixed level of heater output is required to balance the cooling power of the cryostat. This is usually achieved by an integrator circuit, which senses the steady state offset signal (in the proportional band) and "resets" the power to a slightly higher level in small steps proportional to the offset. Once the offset goes to zero, the reset action stops (adding power) and maintains the power output at the correct value to balance the cryostat cooling power. As the temperature increases, the thermal time constant of the cryostat cold head also increases because it is proportional to the heat capacity ratio divided by the

thermal conductivity (this ratio is called the diffusivity) of the cold head. As this happens, the reset setting also needs to be increased.

Most controllers also have a differentiator circuit that provides a signal proportional to the rate of temperature change, which gets subtracted from the proportional output signal. This reduction in effective amplifier gain drives the controller heat output, slowing down the temperature increase rate. This allows more time for the cold head to stabilize and prevents temperature overshoot. The rate setting is more beneficial for controlling large block temperatures because they have large heat capacities and longer relaxation times.

Many temperature controllers now have an autotuning option that selects the appropriate PID values for a specific cryostat. While this option is helpful with some systems, it does not always result in the optimal PID value set that gives the most stable temperature control, especially at liquid helium temperatures.

Having a choice of two or more temperature controller maximum output power settings is good because controlling the temperature of most laboratory cryostats requires low power outputs (less than a watt). If the maximum power output setting is large (say 25 W), this may result in a temperature overshoot at the lower temperatures (1.5 to 20 K).

Finally, it is essential to emphasize that the control sensor (and the heater) must have good thermal anchoring to the block being controlled. The sensor and heater should also be as close to each other as possible to reduce the lag time between when the temperature increase is detected and the actual time heat is introduced into the block. If this lag time is too long, it causes large oscillations in the block temperature. An extreme example would be attempting to control with a sensor located at the sample holder of a SuperVariTemp cryostat, with the heat introduced into the vaporizer. Such configurations should always be avoided.

The Beginner's Guide to Cryostats and Cryocoolers

Average thermal conductivity in W/cm·K

$T_2 - T_1$ (K)	300 to 77	300 to 20	300 to 4	77 to 20	77 to 4	20 to 4	4 to 2
Copper (electroplate T-P)	4.1	5.4	5.7	9.7	9.8	10	4
Stainless steel	0.123	0.109	0.103	0.055	0.045	0.009	0.002
Constantan wire	0.22	0.21	0.2	0.16	0.14	0.04	0.006
Aluminum	2.0	3.0	3.0	2.0	2.0	0.8	0.3
Brass	0.81	0.70	0.67	0.31	0.26	0.08	0.02
G-10-CR	4.5×10^{-3}	4.5×10^{-3}	4.0×10^{-3}	3.9×10^{-3}	2.3×10^{-3}	1.3×10^{-3}	4.5×10^{-4}

Table 5.1: Average thermal conductivity in W/cm·K (Ref. 1, Ch. VII, Ref. 4)

C. Useful cryogenic data and references

This section contains useful information to help estimate the heat load into the cryostat cold region or the cryogen amount necessary for cooldown. It also lists several more detailed references.

1. Thermal conductivities and conductive heat loads

The heat flow Q_1 through a solid of cross-section A , under a temperature gradient dT/dx is given by:

$$Q_1 = kA \frac{dT}{dx} \quad 5.1$$

where k is the (temperature-dependent) thermal conductivity of the material. If the two ends of a long section of this material (of length l) are held at temperatures T_1 and T_2 , then the heat flowing from the warm to the cold end is:

$$Q_1 = \frac{A}{l} \int_{T_1}^{T_2} k(T) dT = \frac{A}{l} k_{av} (T_2 - T_1) \quad 5.2$$

where k_{av} is the mean heat conductivity between the two temperatures and is defined as:

$$k_{av} = (T_2 - T_1)^{-1} \int_{T_1}^{T_2} k(T) dT \quad 5.3$$

Table 5.1 lists the mean conductivity of the most commonly used low-temperature materials at temperatures T_2 and T_1 . These values can be used to estimate the conductive heat loads down tubes, wires, supports, etc., without requiring detailed knowledge of the thermal conductivity as a function of temperature.

2. Radiational heat loads

The radiational heat load from a warm surface at temperature T_2 to a cooler surface at temperature T_1 can be expressed as

$$Q_r = S(T_2^4 - T_1^4)/V \quad 5.4$$

where S is the Stefan-Boltzmann constant ($5.67 \times 10^{-8} \text{ W/m}^2 \cdot \text{K}^4$) and V is the view factor (Ref. 5, Ch. 8 and Ref. 6, Ch. 7),

$$V = (1 - e_2)/e_2 A_2 + F_{21}/A_2 + (1 - e_1)/e_1 A_1 \quad 5.5$$

e_1 and e_2 are the emissivities of the two surfaces, A_1 and A_2 their areas, and F_{21} is the configuration factor determined by the two surfaces' relative geometry.

Two helpful configuration factors for cylindrical metal Dewars are those for concentric cylinders and for parallel discs. For long (compared to the radius) concentric cylinders and for two parallel discs of radii r_1 and r_2 , separated by a distance h , the view factor in both cases is a number of the order of 1. Therefore, the view factor for both configurations can be approximated by

$$V = 1/e_2 A_2 + (1 - e_1)/e_1 A_1 \quad 5.6$$

Combined with the reported values of emissivities listed below, quick estimates can be made for the radiational heat loads from room temperature, nitrogen temperature, or helium temperature surfaces.

The Beginner's Guide to Cryostats and Cryocoolers

Experimental emmissivity values		
Material	Radiation from:	
	300 K to 77 K	77 K to 4.2 K
Al – anodized	0.78	0.67
Al – oxidized	0.5	–
Al – as found	0.12	–
Al – mechanically polished	0.1	0.06
Al – electropolished	0.075	0.036
Cu – as found	0.12	0.06
Cu – mechanically polished	0.06	0.023
SS – as found	0.34	0.12
SS – mechanically polished	0.12	0.03
SS – electropolished	0.1	0.065
SS – as found with Al foil	0.056	0.011

Table 5.2: Experimental emmissivity values (Ref. 7)

3. Thermal expansion

When a cryostat is cooled down to helium temperatures, the various components contract. Knowing the relative contraction for the various materials typically used in such cryostats is useful. Most of the contraction usually occurs when the cryostat has been cooled to liquid nitrogen temperatures. Therefore most leaks show up at liquid nitrogen temperature. Knowledge of the relative contraction is also helpful in designing joints or mechanical contacts, thermal contacts, or standoffs at low temperature.

Thermal expansion data	
Material	Percentage change in length (room temperature to 4.2 K)
Aluminum	0.414
Copper	0.326
304 stainless steel	0.296
Brass (70 Cu 30 Zn)	0.369
Brass (65 Cu 35 Zn)	0.384
G-10CR (warp)	0.241
G-10CR (normal)	0.706
Nylon	1.39
Teflon	2.14
Fused silicon	0.001
Sapphire (z-axis)	0.007
Sapphire (x-y)	0.006

Table 5.3: Thermal expansion data (Ref. 2, Appendix B and Ref. 8, Ch. 3)

4. Experimental data for cooldown

The following information about common cryogenes and metals used in commercial cryostats is helpful in estimating the necessary cryogen amount for cooldown to helium temperatures.

Experimental data for helium and nitrogen				
	Normal boiling point	Liquid density at boiling point (g/cm ³)	Heat of vaporization (Joule/cm ³)	Volume of gas at STP from 1 liquid L
He ²	3.2 K	0.06	0.48	449 L
He ⁴	4.2 K	0.13	2.6	740 L
N ₂	77.4 K	0.81	160	682 L

Table 5.4: Experimental data for helium and nitrogen (Ref. 9, Ch. 8)

Densities of SS, CU, and Al	
Stainless steel	7.86 g/cc
Copper	8.96 g/cc
Aluminum	2.70 g/cc

Table 5.5: Densities OF SS, Cu, and Al (Ref. 10, Appendix H)

Enthalpy (joules/g)

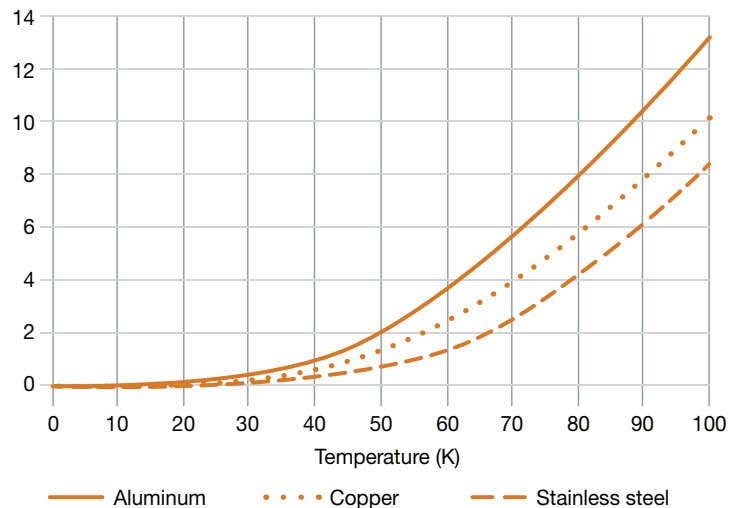

Table 5.6: Enthalpy of SS, Cu & Al (Ref. 9, Ch. 8)

The Beginner's Guide to Cryostats and Cryocoolers

Amount of helium to cool common metals liters of liquid helium per Kilogram of metal

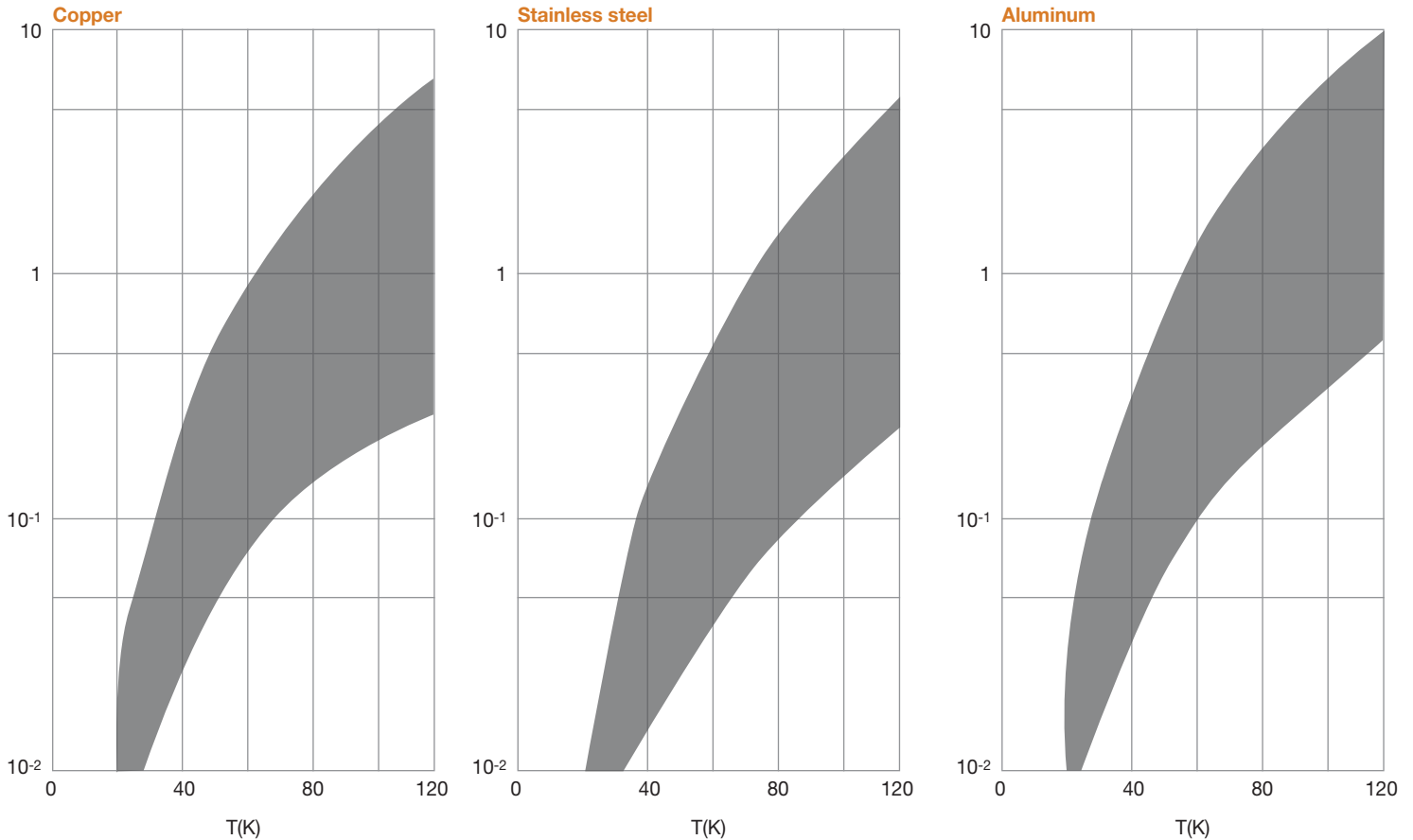

Table 5.7: Amount of helium to cool common metals (Ref. 9, Ch.3)

References and suggested reading list

1. G. K. White, Heat Transfer, (Oxford University Press, London, 1968).
2. G. K. White & P. J. Meeson, Experimental Techniques in Low Temperature Physics. 4th Ed. (Oxford University Press, New York, 2002).
3. G. W. Green, The Design and Construction of Small Vacuum Systems, (Chapman and Hall, London, 1986).
4. J. R. Benzinger, Properties of Cryogenic Grade Laminates, Electrical/Electronics Insulation Conference, Boston, (1979).
5. J. P. Holman, Heat Transfer, (McGraw-Hill, New York, 1981).
6. R. Siegel and J. R. Howel, Thermal Radiation Heat Transfer, (McGraw-Hill, New York, 1981).
7. W. Obert, J. R. Coupland, D. D. Hammond, T. Cook, and K. Harwood, Advances in Cryogenic Engineering, Vol. 27, p. 293 (1982).
8. Materials at Low Temperatures, R. P. Reed and A. F. Clark, Eds., (American Society for Metals, Metals Park, OH, 1983).
9. A.C. Rose-Innes, Low Temperature Laboratory Techniques, (English Universities Press, London, 1973).
10. J. M. Gere & S. P. Timoshenko, Mechanics of Materials, 3rd Ed., (PWS-KENT, Boston, 1990).
11. M. N. Wilson, Superconducting Magnets, (Oxford University Press, London, 1983).
12. Experimental Techniques in Condensed Matter Physics, R. C. Richardson and E. N. Smith, Eds., (Addison-Wesley, New York, 1988).
13. R. B. Scott, Cryogenic Engineering, (Met-Chem Research Inc., Boulder, 1989).
14. F. Pobell, Matter & Methods at Low Temperatures, 3rd Ed. (Springer, Berlin, 1992).
15. T. M. Flynn, Cryogenic Engineering, (Dekker, New York 1997).
16. J. W. Ekin, Experimental Techniques for Low Temperature Measurements, (Oxford University Press, New York, 2006).