

Surface potential sensor Characterizing langmuir films

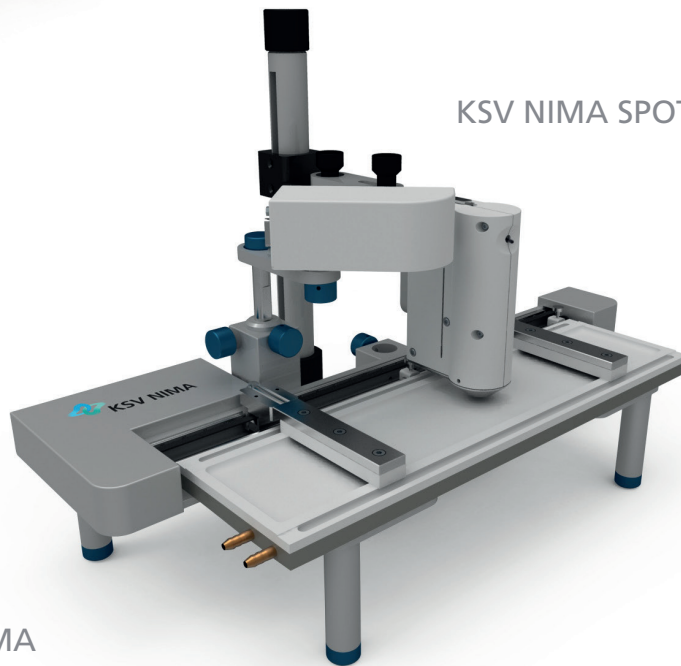

KSV NIMA SPOT



KSV NIMA SPOT

KSV NIMA
Langmuir Trough

Surface potential sensor

Characterizing langmuir films

The KSV NIMA Surface Potential Sensor is a compact and highly sensitive characterisation instrument that offers complementary data on the packing and orientation of Langmuir films. The KSV NIMA Surface Potential Sensor (SPOT) measures the potential difference above and below the film.

[APPLICATIONS]

The KSV NIMA Surface Potential Sensor allows complementing data from surface pressure - area isotherm measurements that are obtained from a Langmuir and Langmuir-Blodgett Trough. It allows the determination of monolayer composition, molecular orientation, degree of molecular dissociation and molecular interactions at the interface. The most common applications are:

Determining effective dipole moments

The KSV NIMA SPOT can be used to determine effective dipole moments through simple surface potential measurements of a compressed film.

Determining molecular orientation

The KSV NIMA SPOT can be used to obtain information on molecular orientation by observing changes in surface potential and combining the data with surface pressure information.

Film electronic structure characterisation

Even the smallest change in the electronic structure of molecules can be detected by measuring the change in surface potential.

Molecular structure characterisation

Quantify the effects of changes to molecular structure through positional offsets and peak values of the surface potential plots.

Complex formation monitoring

Observe and follow complex formations between monolayers, subphase species or adsorbates.

[WORKING PRINCIPLE]

The KSV NIMA Surface Potential Sensor measures the potential difference above and below the film and is sensitive to the sum of all the individual dipole moments. The changes in surface potential are measured by detecting the potential difference between the vibrating plate which is placed above the monolayer and the counter electrode which is immersed in the subphase below the monolayer.

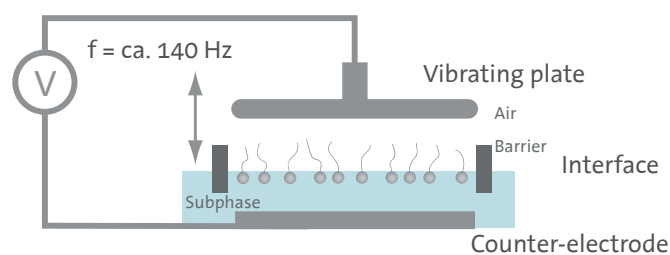

$$\Delta V = \mu_n / \epsilon \cdot \epsilon_0 \cdot A$$

with

ϵ = subphase permittivity (e.g. here water)

ϵ_0 = air permittivity

A = area per molecule

μ_n = vertical component of the dipole moment

Surface potential sensor

Characterizing langmuir films

GRAPH 1

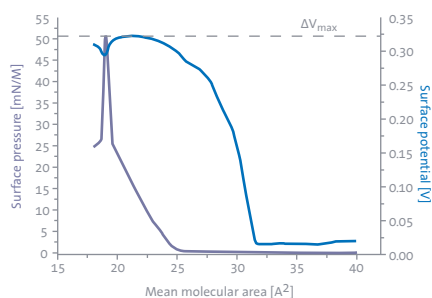

GRAPH 2

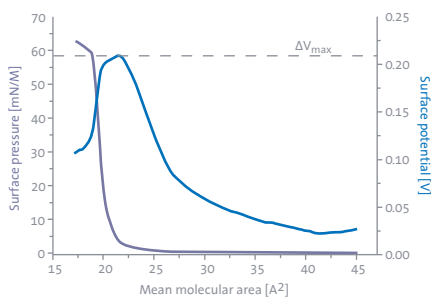

GRAPH 3

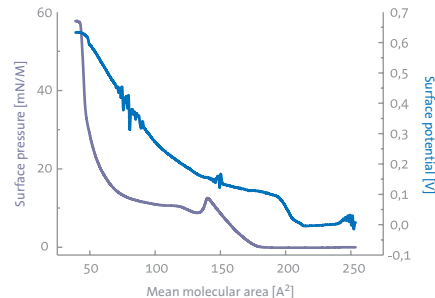

Product Benefits

Accurate and reproducible measurements

The non-contact and non-destructive vibrating plate capacitor method ensures very good accuracy and reproducibility.

Integrated software

The KSV NIMA Surface Potential Sensor does not require any additional software and can be easily installed by a simple plug and play operation. The latest version of KSV NIMA LB Software, supplied with all KSV NIMA Langmuir and Langmuir-Blodgett Deposition Troughs, displays the recordings of the surface pressure and surface potential on the same plot. Colour coded axes and plots ensure that the two recordings are clearly presented.

Easy set up

The KSV NIMA Surface Potential Sensor connects directly to your existing KSV NIMA Interface Unit, supplied with all KSV NIMA Langmuir and LB Deposition Troughs. The KSV NIMA SPOT is provided with a flexible stand allowing rapid and easy integration to your trough. Furthermore, the instrument is factory calibrated for a quick start up.

Compatibility

It is recommended to use the KSV NIMA Surface Potential Sensor together with a KSV NIMA Langmuir, Langmuir-Blodgett or Microscopy Trough to be able to combine surface pressure and surface potential measurements.

Measurement examples

Graph 1 & 2

Using a KSV NIMA Langmuir Trough, a monolayer of Stearic acid was spread onto a subphase and the surface potential was measured with the KSV NIMA SPOT. The first experiment (Graph 1) used a subphase of deionised water (pH=5.6). In the second experiment (Graph 2) a solution of Cadmium Chloride ([c]=0.1 mM, pH=6.7) was used as a subphase. The surface pressure - area isotherm and the surface potential (ΔV) data were recorded using the KSV NIMA LB Software which automatically records both plots simultaneously.

In the case of Graph 1 (deionised water), ΔV_{max} was found to be 322 mV. Upon changing the subphase from water to cadmium chloride (Graph 2), the measured ΔV_{max} was reduced to 209 mV. This lower ΔV_{max} value can be explained by the interaction of Cd^{2+} ions with the dissociated carboxylic acid head groups of the Stearic acid monolayer, contributing to a decrease in surface potential. These results are in very good agreement with literature.

Graph 3

The KSV NIMA LB Software graph displays both the surface pressure-area and the surface potential-area isotherms of an antiparasitic drug monolayer on an air-buffer solution interface. An unusual surface pressure-area transition was observed at mean molecular area of 140 Å², but no transition was shown in the surface potential-area isotherm. This suggests that the transition is not a phase transition but instead the drug could undergo aggregation, dimerization or conformational change at this mean molecular area.

Surface potential sensor Characterizing langmuir films

Technical Specifications

Measurement

Input range: -5V to +5V
Sensitivity: +/- 1mV
Height dependency: 10mV/mm
Response time: Proportional to distance but less than 1s when positioned 1 mm above monolayer
Calibration: Factory calibrated

Hardware

Measuring head dimensions: 100x85x20mm
Probe diameter: 16mm
Stand base height: 19mm
Maximum sensor height: 160mm
Counter-electrode plate dimensions: 35x50x2mm
Vertical electrode arm length: 20mm

Software

Fully incorporated into KSV NIMA LB Software for Langmuir and Langmuir-Blodgett Troughs.

Specifications and appearance are subject to change without prior notice. Biolin Scientific shall not be liable for any errors in this document.

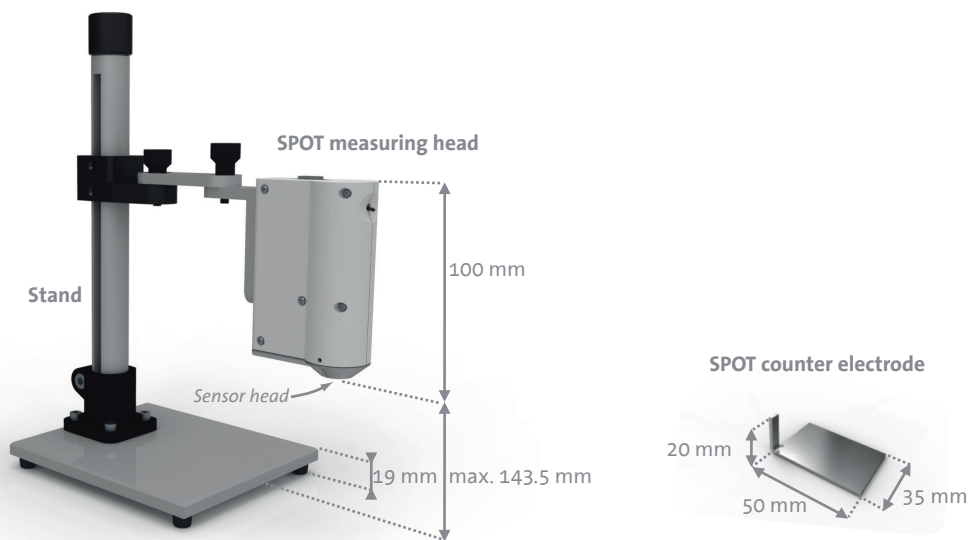

The counter electrode is placed in the subphase with the arm protruding through the subphase surface. This plate is connected to the SPOT measuring head by a cable.