

Light sources and optical filters

The best monochromatic light source of course is a laser. But tunable lasers are expensive.

More economical is to combine a light source with one or more narrow band optical filters or with a monochromator. There are advantages and disadvantages.

Advantages

- Filters give much larger throughput for large area sources. Depending on the source size and bandwidth required, the throughput can be 5 – 500 times that of a monochromator.
- Filters can be much more economical if you only need to work at a few known wavelengths.

Behind the filter, the light can be focused with a lens, coupled into a fiber, or turned by a mirror.

Thermal problems

Absorbed radiation heats the filter components. The optical cement absorbs infrared while the blocking glasses, by design, absorb the VIS-IR. UV filters are designed to absorb the visible and IR, so they heat up very quickly when exposed to an arc or halogen source.

Heating an interference filter for a period of time causes a small non-reversible shift in the center wavelength. This shift is usually to shorter wavelengths.

The optical cements used in most laminated filters degrade at temperatures above 80 °C. They darken and, by absorbing more, accelerate the deterioration of the filter. Thermal shock, or other thermal stress can fracture the filter elements. Thermal shock is due to rapid local heating as with sudden application of a high power beam. Non uniform heating can produce destructive steady thermal stresses.

Heating of an optical filter changes the spacing and thickness of the various layers. Usually a temperature increase causes a shift to longer wavelengths. A shift of about 0.003% of the peak wavelength per °C is typical.

Angle effects in narrowband filters

Interference filters should be used in a collimated beam if narrow band performance is required. If you tilt the filter in a collimated beam, the transmission peak shifts to shorter wavelengths. Shifts of 2% of peak (12 nm for a 600 nm filter) are typical for a 20 degree angle of incidence. Band broadening and lower transmission result if the angle of incidence exceeds 20°. Polarization effects also become significant at higher angles.

If you direct an uncollimated beam onto an interference filter, the transmission curve will be a weighted average over all the angles of incidence. The transmission band for an uncollimated beam is broader, with the peak shifted to shorter wavelengths.

Guidelines

Interference filters should absorb as little radiation, particularly infrared radiation, as possible. Because of the variety of light sources with different spectral and spatial distributions, and because of the different materials used in filters, we cannot make definitive statements about power loading. For example, a filter to isolate the 514.5 nm laser line from low level ambient can operate at high power density because little light is absorbed. The same filter will be destroyed if exposed to much lower levels of 1.06 μm radiation.

- Turn the reflective side of the filter towards the incoming light.
- Use the filter in as large a beam as possible. Never focus a beam on a filter.
- Use a beam Turner with a dichroic mirror or the combination of water filter and infrared absorbing glass. Because of the non-reversible effects we recommend that the temperature of the filters does not exceed 70 °C and that the rise in temperature does not exceed 5 °C per minute.

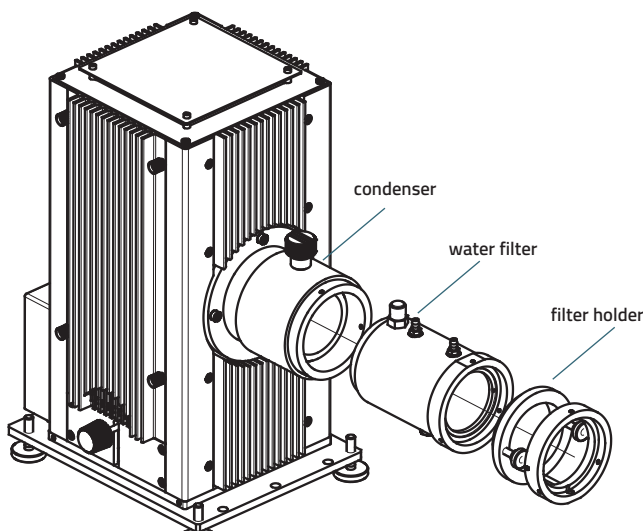

Light source accessories