

Xenon arc light sources

75-150 W

Typical Xenon spectra of ozone free lamp

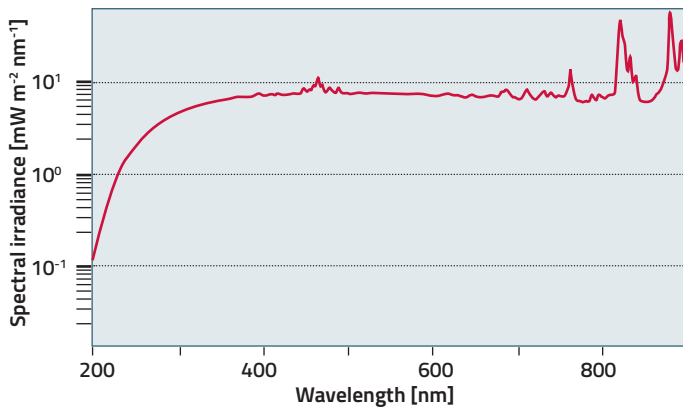

- Continuous output from UV-VIS
- Simulation of solar spectrum
- Convection cooled housing
- Precision external lamp adjustment
- Supports wide range of accessories

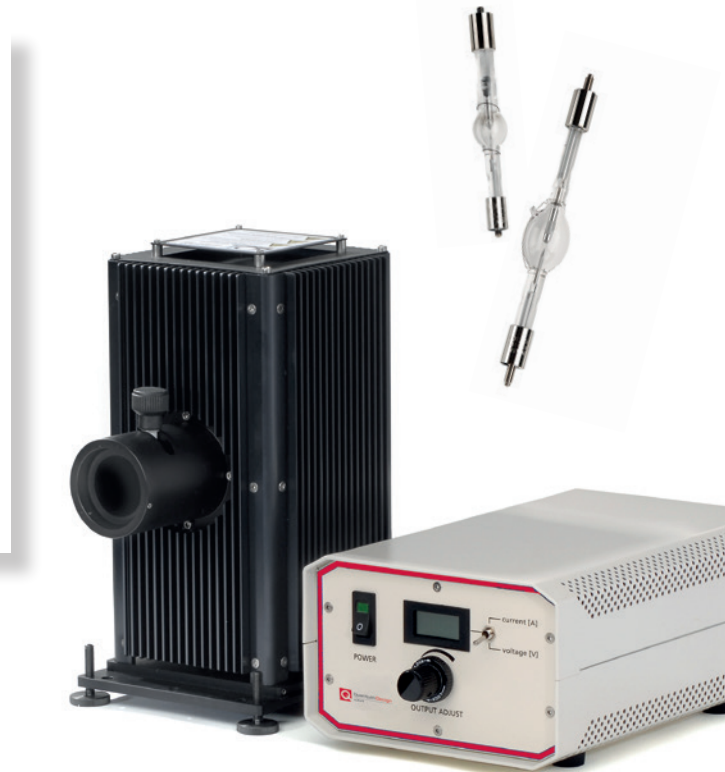

Xenon light source with lamp examples and power supply

Xenon short arc lamp

Xe lamps are filled with pure xenon gas at 8 – 10 bars. The pressure triples during operation.

With 6000 – 6500 K they closely approach the color temperature of the sun. The typical xenon lines dominate between 750 and 1000 nm, but the spectrum is almost smooth through the ultraviolet and visible. Special UV versions emit down to ~200 nm. Ozone free lamps have bulbs that absorb below 300 nm and have a cut-off around 280 nm.

Convection cooled housing

Unlike fan cooled housings, this housing uses natural convection cooling. This type of cooling is acoustically quiet and vibration free, which results in the most stable lamp output. Openings in the bottom and top of the housing allow air to enter and circulate through the housing without excessive light leakage. The ribbed exterior improves the cooling efficiency.

The housing has precise external lamp adjusters that allow you to place the arc where you want it. This is important for simplifying fiber and slit illumination. For many applications, this eliminates the need to readjust optics that are in the beam path outside the housing.

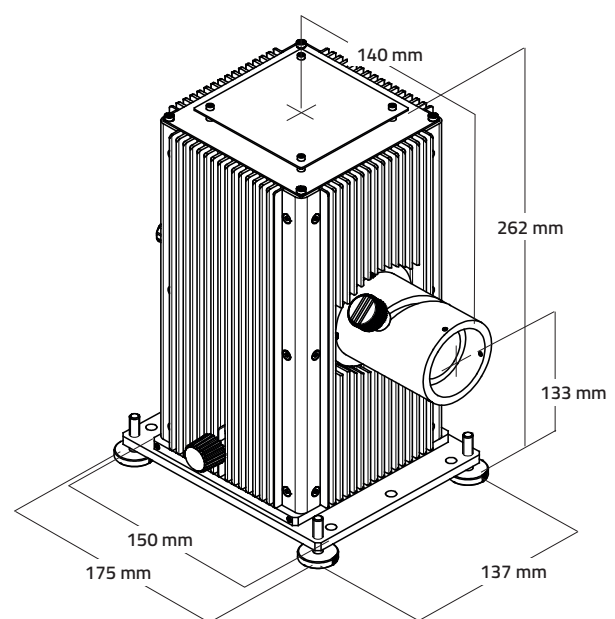

Dimensions Xenon light source

Xenon arc light sources

75-150 W

Power supply

Our power supplies are easy to use. A self-explaining menu navigation allows easy setup of the light source and safe lamp operation. The power supply comes factory-preset for the specific lamp ordered. The lamp is automatically operated within its admissible current/voltage range and spares you extensive adjustments through the lamp's warm-up period to establish the operating power.

Condensing optics

We offer a variety of different condensers with 25 mm or 35 mm nominal aperture. They differ in:

- Lens material and therefore usable spectral range
- F/number and therefore beam quality and collection/collimation efficiency

The condensers are intended for collimated beams but can also be positioned for compensating focal length change due to dispersion and to produce a more diverging or converging beam. For best uniformity use a slightly diverging beam. For best quality images use the condenser as a collimator and a secondary focusing lens. The condenser lenses are made of high-quality UV quartz for transmissions down to 200 nm, or optical borosilicate glass (BK7; B270) for applications, where an output below 360 nm is not required.

Rear reflector

The optional reflector assembly collects additional radiation from the source, thus increasing the output by up to 50 % for arc lamps. The reflector assembly has a wideband AlMgF₂ coated mirror, usable from the UV to the IR. Control knobs provide x, y, and z adjustments for tilt and focus.

A word on safety

When using arc lamps, you have to operate the housing only with a condenser or window because of possible lamp burst! Even with these low powered sources, UV radiation and ozone are a concern. The easiest solution to the ozone problem is to use an ozone-free arc lamp if you do not need output below ~260 nm. If that is not an option, vent the ozone. Take appropriate UV safety precautions; enclose the beam or wear UV protective eyewear and gloves.

Learn more about UV safety: "[Ultraviolet safety considerations](#)".

Ordering information

The LSxxx light source **includes** almost everything needed for proper operation (lamp housing, power supply, cables and adapters).

Only select lamp and condensing optic according to your requirements to complete.

The optional rear reflector is strongly recommended to maximize output power.

Part number	Description
LS75Xe	75 W Xenon light source
→ LSB510	75 W Xe lamp
→ LSB511	75 W Xe lamp (ozone free)
LS150Xe	150 W Xenon light source
→ LSB520	150 W Xe lamp
→ LSB523	150 W Xe lamp (ozone free)
→ LSB522	150 W Xe lamp UV (ozone generating)

Condensing optics

Part number	Nominal Ø [mm]	f-number	Lens material
LSC105	25	1,2	UV quartz
LSC115	35	1,3	UV quartz
LSC110	35	1,0	UV quartz
LSC116	35	1,3	glass
LSC111	35	1,0	glass

Rear reflector

Part number	Description
LSC121	Rear reflector

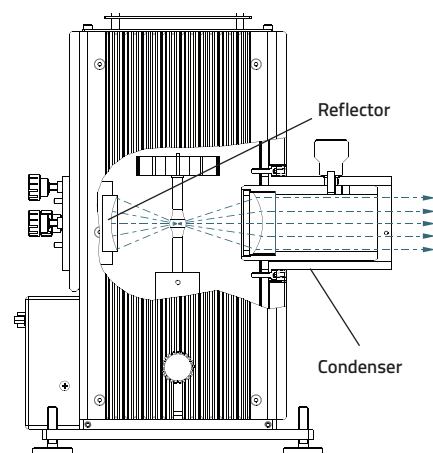

Functional diagram Xenon light source