

Optical Sample Pods

Swapping out samples and experiments is easy and convenient using OptiCool's Sample Pod technology. The removable pod provides you a place to build and customize your experiment on the bench. When you are ready to make a measurement, the pod easily plugs into the pre-wired Sample Column, connecting all the experimental wires at once. Having multiple experiments arranged on multiple pods allows you to switch experimental hardware quickly. Sample pods are available in both a standard configuration and a large-volume configuration, depending on your experimental needs.

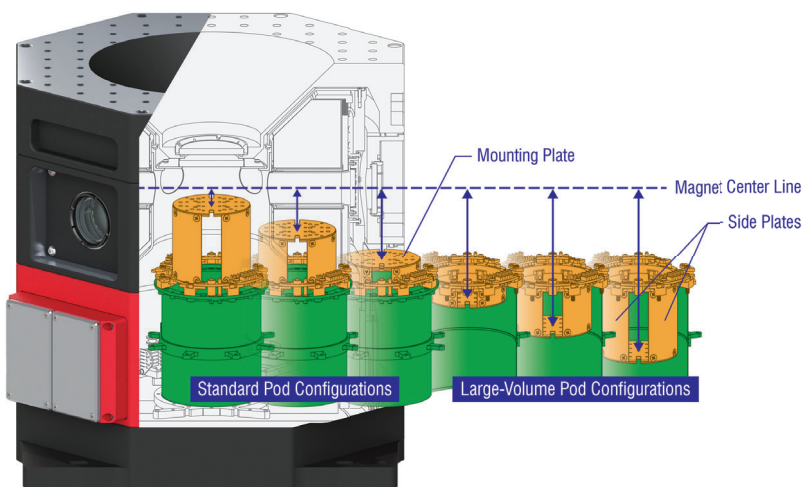

The location of the mounting plate relative to the Magnet Center Line can be adjusted by swapping out the two curved Side Plates. There are three standard sizes of side plates that come with either the standard or large-volume sample pod. These side plates allow the mounting plate to be positioned at three different distances either above or below the pod flange (see illustration above).

See the *Standard and Large-Volume Sample Pods* section on page 5 for more details.

Configuring the Sample Pods

Samples and experimental hardware are attached to the pod via the Mounting Plate. The mounting plate has a 4x4 grid of imperial #4-40 tapped holes (shown in red below) as well as other common hole patterns for mounting piezo positioners. This plate is replaceable and can have custom holes added if desired. Slots in the mounting plate make it easier to route wires to your hardware and reduce eddy current heating during magnet ramping.

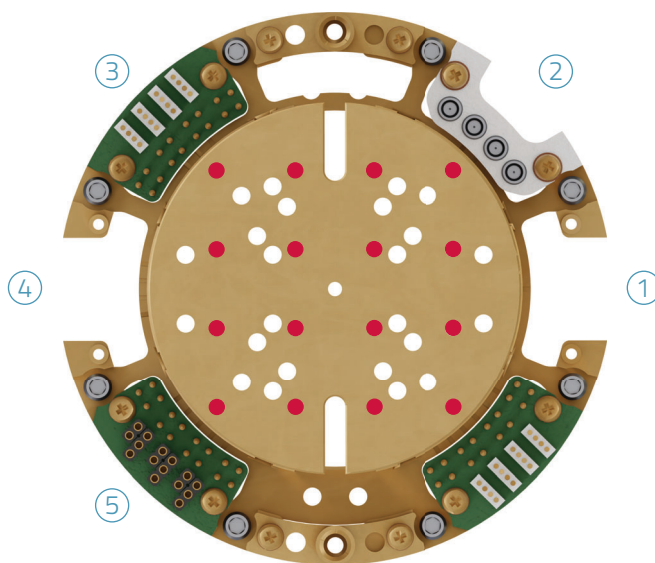

Top down view of sample pod showing 5 available bays for connector boards. In this image, bay 2 shows RF coax connectors, bay 3 shows standard sample wiring connectors, and bay 5 shows nanopositioner connectors installed on pod.

Connecting Wires to Your Sample

Each Sample Pod has 5 bays available to mount connector boards. The bays need to be configured to match the pre-installed wiring configuration of your OptiCool. Once properly configured, the connector boards mate up with the OptiCool wiring when the Pod is installed. Each different type of board presents a connector on the top side of the Pod Flange to extend the wires to your sample. Mating connectors for each board style installed in the system are included with the OptiCool. For more information regarding available pre-wired options, see the *OptiCool Wiring and Feedthrough Options* section on page 6.

Standard and Large-Volume Sample Pods

Sample pods are available in both a Standard configuration and a Large-Volume configuration. Each pair of side plates is compatible with both types of sample pods.

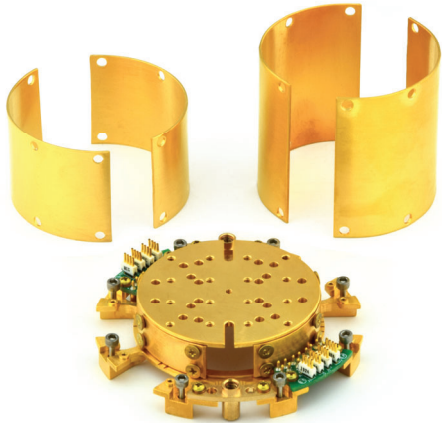

X100 – Standard Sample Pod

The Standard Sample Pod allows you to position the mounting plate at three different locations within the sample volume. This is accomplished by swapping out the pod side plates. The available side plates allow you to locate the mounting plate at either 12.4 mm, 32.8 mm, or 56.4 mm below the magnet center line position. The standard sample pod is useful for mounting smaller experimental setups, shorter stacks of positioners, or samples higher up in the sample volume.



X110 – Large-Volume Sample Pod

The Large-Volume Sample Pod allows you to position the mounting plate at three different positions below the pod flange, allowing utilization of the volume inside the Sample Column. Like the Standard Sample Pod, this is accomplished by swapping out the pod side plates. The available side plates allow you to locate the mounting plate 87.4 mm, 111.0 mm, or 131.3 mm below the magnet center line.

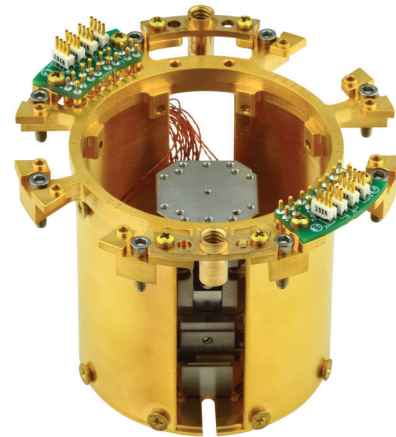

The sample pod is available in standard and large volume configurations. The large-volume sample pod (above) is useful for mounting tall experimental setups or including more complex stacks of positioners while keeping the sample in the center of the magnetic field.

Re: 1318-016 Rev. A0